

**44120 LINK CHAIN BASKET ASSEMBLY INCLUDES:**

<b>CHAIN BASKET - CANVAS</b>	<b>44119</b>
<b>BRACKET (R.H.)</b>	<b>44113</b>
<b>BRACKET (L.H.)</b>	<b>44114</b>
<b>BOLT</b>	<b>Y19-89-S</b>
<b>WASHER</b>	<b>Y14-8</b>
<b>NUT</b>	<b>Y22-8</b>
<b>BOLT (4 REQ'D)</b>	<b>Y19-104</b>
<b>WASHER (4 REQ'D)</b>	<b>Y14-10</b>
<b>NUT (4 REQ'D)</b>	<b>Y22-10</b>
<b>INSTRUCTION SHEET</b>	<b>49999-446</b>

**TO ASSEMBLE TO HOIST: TAKE HOIST OUT OF SERVICE AND REMOVE SCREW (Y154-43) WHICH ANCHORS END OF LOAD CHAIN TO LUG ON HOIST HOUSING AND ASSEMBLE CHAIN BASKET TO HOUSING LUG USING HARDWARE PROVIDED. BE SURE UPPER CHAIN STOP IS PROPERLY SECURED TO LOAD CHAIN.**

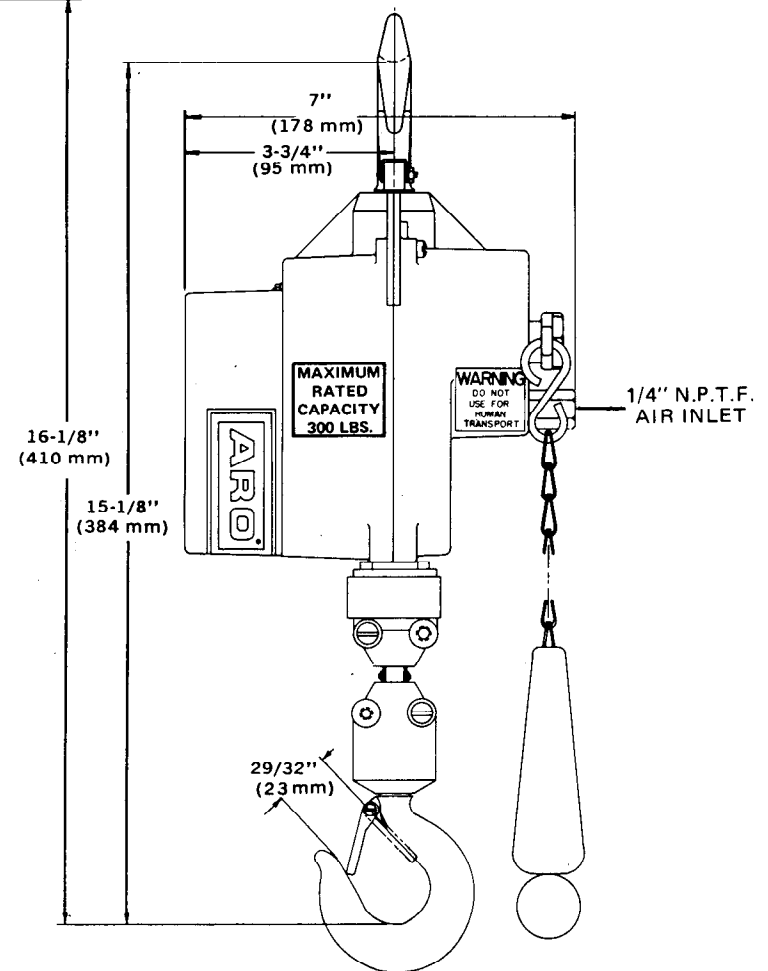
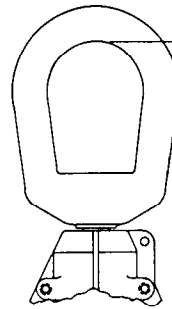
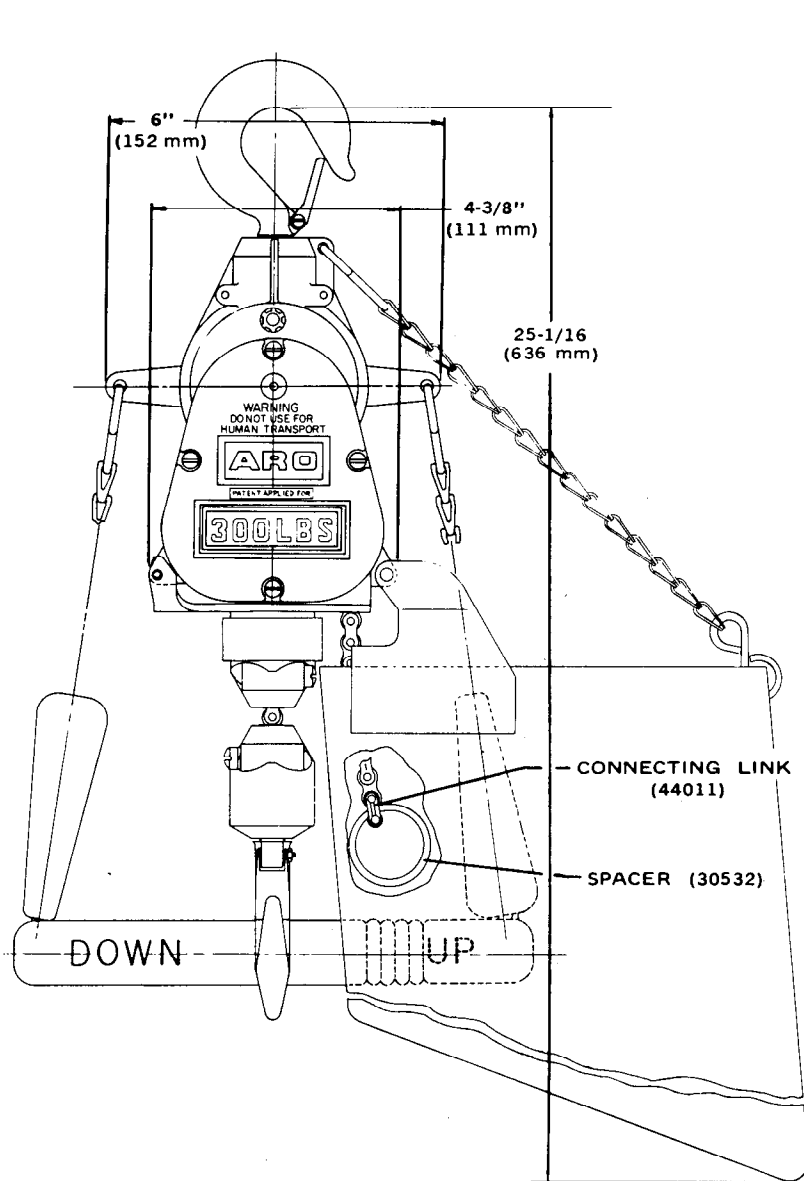

**44595 ROLLER CHAIN BASKET ASSEMBLY INCLUDES:**

CHAIN BASKET AND BRACKET	44592
SPACER	30532
SASH CHAIN	37657-H
"S" HOOK (2 REQ'D)	37659
LOCKWASHER	Y14-10
NUT	Y22-10
CAP SCREW	Y154-53

TO ASSEMBLE TO HOIST: TAKE HOIST OUT OF SERVICE AND REMOVE CONNECTING LINK (44011) FROM HOUSING AND REMOVE UPPER CHAIN STOP FROM CHAIN. ATTACH SPACER (30532). ATTACH BASKET USING HARDWARE PROVIDED AS SHOWN (SEE ADJACENT VIEW).