



Tool & Hoist Products

# OPERATOR'S MANUAL

INCLUDING: OPERATION, INSTALLATION & MAINTENANCE

## 7700-E AND -ET SERIES CHAIN HOISTS 1/4, 1/2 and 1-TON MODELS

SECTION	M50
MANUAL	12
Released:	10/81
Revised:	9-9-94
Form:	2024-2

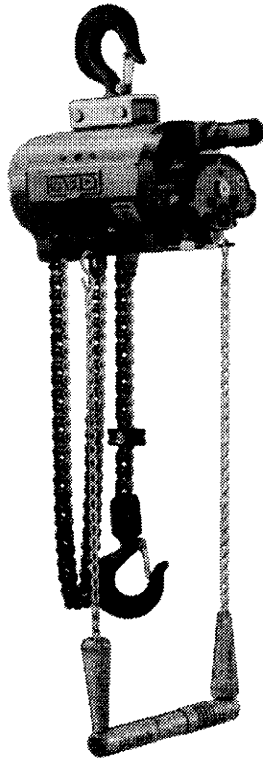

7700-E

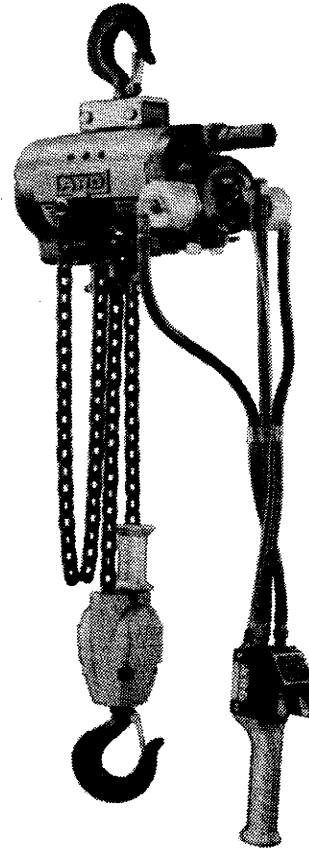

7776-E

### FEATURES:

- 1/4, 1/2 OR 1 TON LINK CHAIN MODELS
- 400, 800 OR 1600# ROLLER CHAIN MODELS
- LINK OR ROLLER CHAIN TYPE LOAD CHAIN
- PULL-CHAIN OR PENDENT TYPE THROTTLE CONTROL
- HOOK OR TROLLEY SUSPENSION MOUNTING

INDEX	PAGE
MODEL IDENTIFICATION .....	2
INSTALLATION .....	2 and 3
AIR AND LUBE REQUIREMENTS .....	4
OPERATION .....	4 and 5
INSPECTION AND MAINTENANCE .....	6
LOAD CHAIN REMOVAL AND BRAKE ADJUSTMENT .....	7
DISASSEMBLY AND ASSEMBLY .....	8 thru 19
SPARK-RESISTANT HOIST SECTION .....	20 and 21
ACCESSORIES .....	21 thru 25
TROUBLESHOOTING .....	23
CHAIN BASKET INSTALLATION .....	25

**IMPORTANT: READ THIS MANUAL CAREFULLY BEFORE INSTALLING, OPERATING OR SERVICING THIS EQUIPMENT.**

For parts and service information, contact your local ARO distributor, or the Customer Service Dept. of the Ingersoll-Rand Distribution Center, White House, TN at PH: (615) 672-0321, FAX: (615) 672-0601.

ARO Tool & Hoist Products

Ingersoll-Rand Company  
 1725 U.S. No. 1 North • P.O. Box 8000 • Southern Pines, NC 28388-8000  
 ©1994 THE ARO CORPORATION • PRINTED IN U.S.A.

**INGERSOLL-RAND®**  
**PROFESSIONAL TOOLS**

## MODEL IDENTIFICATION

MODEL NUMBER			UPPER MOUNTING	TYPE CONTROL	TYPE LOAD CHAIN
400#	800#	1600#			
7719-E	7700-E	7725-E	34921 HOOK ASSEMBLY	PULL CHAIN	ROLLER
7719-ET	7700-ET	7725-ET	TROLLEY ADAPTER	PULL CHAIN	ROLLER
7720-E	7708-E	7732-E	34921 HOOK ASSEMBLY	PENDENT	ROLLER
7720-ET	7708-ET	7732-ET	TROLLEY ADAPTER	PENDENT	ROLLER

MODEL NUMBER			UPPER MOUNTING	TYPE CONTROL	TYPE LOAD CHAIN
1/4 TON	1/2 TON	1 TON			
7717-E	7750-E	7775-E	34921 HOOK ASSEMBLY	PULL CHAIN	LINK
7717-ET	7750-ET	7775-ET	TROLLEY ADAPTER	PULL CHAIN	LINK
7718-E	7756-E	7776-E	34921 HOOK ASSEMBLY	PENDENT	LINK
7718-ET	7756-ET	7776-ET	TROLLEY ADAPTER	PENDENT	LINK

### EXTRA-FAST DESCENT HOISTS

MODEL NUMBER			UPPER MOUNTING	TYPE CONTROL	TYPE LOAD CHAIN
400#	800#	1600#			
	7706-E	7730-E	34921 HOOK ASSEMBLY	PULL CHAIN	ROLLER
	7706-ET	7730-ET	TROLLEY ADAPTER	PULL CHAIN	ROLLER
	7710-E	7734-E	34921 HOOK ASSEMBLY	PENDENT	ROLLER
	7710-ET	7734-ET	TROLLEY ADAPTER	PENDENT	ROLLER

MODEL NUMBER			UPPER MOUNTING	TYPE CONTROL	TYPE LOAD CHAIN
1/4 TON	1/2 TON	1 TON			
	7754-E	7777-E	34921 HOOK ASSEMBLY	PULL CHAIN	LINK
	7754-ET	7777-ET	TROLLEY ADAPTER	PULL CHAIN	LINK
	7758-E	7778-E	34921 HOOK ASSEMBLY	PENDENT	LINK
	7758-ET	7778-ET	TROLLEY ADAPTER	PENDENT	LINK

For spark-resistant models, see spark-resistant hoist section, page 20.

Furnished with trolley adapter assembly (assembly number 47717 for 1/4 and 1/2 ton models; assembly number 47716 for 1 ton models) for mounting manually operated trolley to hoist. Trolley must be ordered separately. See page 22.

## INSTALLATION

**WARNING: THE HOISTING EQUIPMENT SHOWN AND DESCRIBED IN THIS MANUAL SHALL NOT BE USED TO LIFT OR TRANSPORT HUMAN CARGO.**

The hoist shall be installed only in locations that will permit the operator to stand free of the load at all times.

Your ARO hoist is completely lubricated and load tested before being shipped from the factory. To place in service:

### HOOK SUSPENDED MODELS:

Select an overhead support capable of safely supporting combined weight of hoist and its capacity load. Hang hoist, being certain the upper hook is firmly seated in the center of the hook saddle and that the safety latch is properly closed. The use of a secondary safety cable is recommended, see page 24.

### TROLLEY SUSPENDED MODELS:

The trolley side plates must be spaced so the trolley wheels will properly engage the beam on which the trolley will be operated. Adjustment for various beam sizes is accomplished by arrangement of the spacer washers on the shaft which connects the trolley side plates. The hoist can be suspended from the trolley by using trolley adapter (part number 47717 for 1/4 and 1/2 ton hoist models, part number 47716 for 1 ton hoist models) or by attaching the upper hook directly to shaft (figure 1). Use of the trolley adapter is recommended.

The distance between the outside edges of the trolley wheels should be approximately 1/2" greater than the width of the beam flange. The number of spacer washers used to space side plates out must be the same on each side of the shaft (or trolley adapter) and the remaining spacers must be equally distributed on the shaft outside the trolley side plates at each side between the side

plates and lock nuts, (see figure 1). When installing the trolley on the beam, be certain side plates are vertical.

Assemble trolley adapter to hoist housing. Determine the number of spacer washers needed to properly space side plates for beam to be used, and assemble shaft to trolley adapter. Assemble spacer washers, side plate, spacer washers and nut to one side of shaft. Position trolley and hoist on beam and assemble spacer washers, side plate, spacer washers and nut to other side of shaft. Tighten nuts securely. The lock nuts must properly engage shaft extending all the way thru the nut. Refer to page 22 for trolley and adapter.

The trolley wheels should be positioned as close as possible to the edge of the beam flange. Operate the trolley over the entire length of the beam track and observe operation. If it appears the trolley side plates can be moved closer together and freedom of movement maintained, remove an equal number of spacer washers from between the side plates and trolley adapter at each side and assemble these spacers to the outside of the side plates between the side plate and lock nuts.

The beam on which the trolley is to be used must safely support the combined weight of the hoist, trolley and capacity load. Minimum turning radius of the trolley is 24" for 1/4 and 1/2 ton models; 36" for 1 ton models.

Connect hoist to nearest air source using a minimum 1/2" i.d. air hose assembly. Sufficient air hose must be provided to reach the farthest point of travel of the trolley.

ARO model 7703 hose trolley assemblies are recommended to keep air hose elevated and in line with the hoist, see page 24.

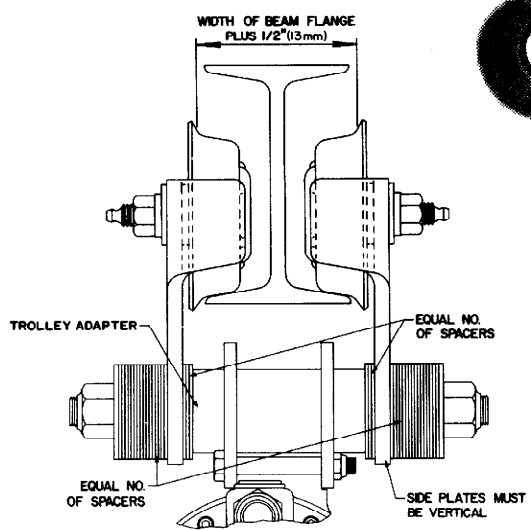
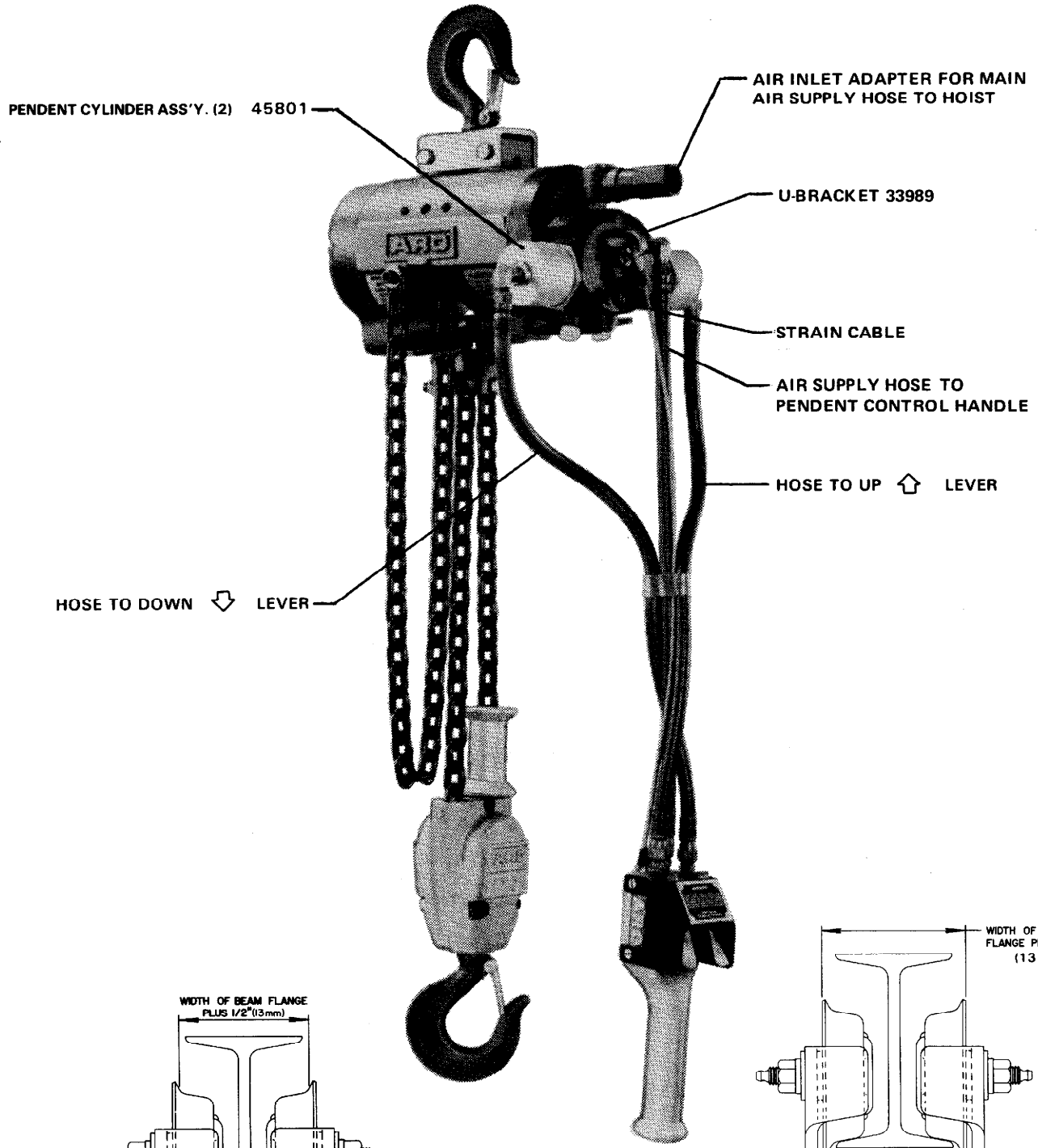

TROLLEY ADAPTER MOUNTING

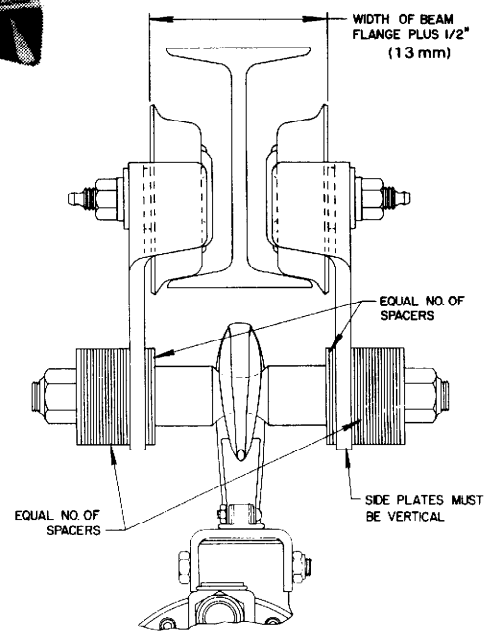

HOOK TO TROLLEY MOUNTING

FIGURE 1

## AIR AND LUBE REQUIREMENTS

AIR PRESSURE of 90 p.s.i.g. (6 bar) at the air inlet of the hoist is required for maximum motor efficiency. If necessary, an air regulator should be installed to maintain this pressure when hoist is in operation.

FILTERED AND OILED AIR will allow the hoist to operate more efficiently and yield a longer life to operating parts and mechanisms. A line filter capable of filtering particles larger than 50 microns should be used with a line oiler.

FILTER-REGULATOR-LUBRICATOR (F-R-L) assembly model 128241-300 is recommended for use with each hoist. The capacity of this F-R-L is adequate to provide clean (40 micron) oiled and regulated air for the hoist. The F-R-L must be installed on the stationary air line, in that order, with the lubricator nearest to the hoist.

LOAD CHAIN LUBRICATION – Chain should be lubricated periodically with heavy "EP" Gear Oil. Occasional cleaning of the chain under normal operation conditions will tend to reduce wear and prolong chain and pocketwheel (or sprocket) life. To properly clean, remove chain from hoist (see page 7) and wash in an oil solvent. Lubricate chain. Under highly contaminated operating conditions, the load chain should

be cleaned and relubricated with greater frequency to remove grit, sand and other contaminants.

OIL RESERVOIR in head should be filled with spindle oil (29665) after each 40 hours of operation.

INJECT GREASE (33153), 2 to 3 strokes, thru grease fitting in hoist housing to provide lubrication for gearing, and thru fittings of trolley wheels a minimum of every 160 hours of operation.

LOWER BLOCK ASSEMBLY should be lubricated at any time the lower block is disassembled either for inspection or for maintenance or for chain replacement. See pages 16 and 17 for lubrication instructions.

RECOMMENDED HOSE SIZE – 1/2" (13 mm) nominal inside diameter.

RECOMMENDED LUBRICANTS: Spindle Oil 29665, 1 qt. (.9 liter) container for oiler and air inlet; Grease 33153, 5 lb. (2.3 kg) can for gears, lower block and bearings; "O" Ring Lubricant 36460, 4 oz. (113 g) tube for lubrication and installation of "O" rings.

PART NUMBER	WHERE USED	DESCRIPTION
29665	AIR MOTOR	A HIGH QUALITY LIGHT TURBINE OR SPINDLE OIL. RUST INHIBITED, WITH VISCOSITY OF 100-150 S.U.S. AT 100°F. OIL IS COMPATIBLE WITH POLYCARBONATE TYPE AIR LINE LUBRICATOR BOWLS.
33153	GEARS & BEARINGS	A HIGH QUALITY "EP" EXTREME PRESSURE ANTI-FRICTION BEARING AND GEAR GREASE, NLGI NO. 1. FREE OF CORROSIVE MATTER AND FILLERS, WITH A VISCOSITY OF APPROXIMATELY 750 S.U.S. AT 100°F.
36460	"O" RINGS & LIP TYPE SEALS	A STRINGY LUBRICANT FOR RUBBER SEALS, WITH GOOD ADHESIVE QUALITIES.

## OPERATION

OPERATE HOIST CAUTIOUSLY to become familiar with the performance of the hoist. Hoist shall be operated from a position that will not be hazardous to the operator. Abrupt operation, resulting from "jerking" of controls, should be avoided.

The rate of lift or descent of any ARO chain hoist can be governed manually by the operator. Both the pull chain and pendant controls provide unlimited variation between full speed and the slowest "INCHING" movement. This is accomplished by movement of pull chain handles or pendant control levers. Pulling down on pull chain control as far as possible or depressing pendant control levers fully will result in maximum hoist speed.

On pendant control models, the control handle is supported by a strain cable to prevent stress on hoses.

BEFORE STARTING TO LIFT, insure chain is properly seated in the sprockets (or pocketwheel). Do not lift or move load more than a few inches until load is well balanced in sling or lifting device. Care shall be taken in hoisting to insure that chain is not kinked or twisted and load does not contact any obstruction. Be certain hoist is centered over load to prevent danger of load swinging when lifted. Side or end

pulling should always be avoided. Take up slack chain carefully to avoid overstress caused by jerking load when lifting. Be certain that safety latch on load hook is properly closed. On 1 ton link chain models – to avoid jamming of chain in lower block, allow only sufficient slack in chain to permit attaching hook to load.

DO NOT wrap the hoist chain around the load. The load shall be attached to the hook by means of slings or other approved devices and shall be properly seated in the saddle of the hook.

The maximum lift rate of a hoist is constant, provided that air pressure and load are also constant. The maximum descent rate of a hoist, with the exception of spark-resistant models (see spark-resistant hoist section), can be varied within fixed limits by means of regulating valves located on the underside of the head housing.

Hoists are shipped from the factory with regulator valves pre-set for slowest rate of descent and fastest rate of lift. If a faster rate of descent is desired, turn regulator valve clockwise by small increments while testing with desired or rated load attached. If a slower rate of lift is desired, turn regulator valve counterclockwise by small increments while testing with desired or rated load.

The operator shall test the brakes each time a load approaching the rated load is handled by raising the load just enough to clear the floor, or supports, and checking for proper brake action and lift continued only if brake is functioning properly.

**CAUTION: DO NOT OPERATE HOIST WITHOUT CHAIN STOP ATTACHED PROPERLY TO HOIST LOAD CHAIN. DO NOT USE CHAIN STOP AS A LIMIT SWITCH (to stop hoist when operating in the "up" mode). The chain stop function is to keep the lower hook components (lower block on 1 ton models) from striking control arm (37719) should an over-run condition ever occur.**

DO NOT EXCEED RATED LOAD CAPACITY OF HOIST.

DO NOT OPERATE HOIST OVER PEOPLE.

**WARNING: DO NOT USE HOIST FOR HUMAN TRANSPORT.**

DO NOT LEAVE LOAD SUSPENDED FOR EXTENDED OR UNATTENDED PERIODS.

INSURE LOAD CHAIN IS HANGING PROPERLY AND IS FREE OF TWISTS, LOOPS OR KINKS.

**WARNING: MAXIMUM LOWERING SPEED WITH RATED CAPACITY LOAD IS VERY HIGH. ADJUST WITH CARE.**

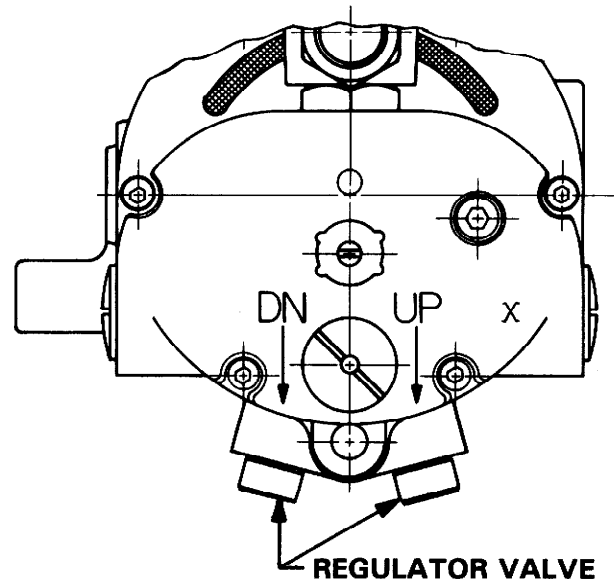
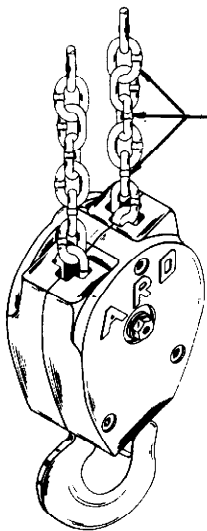
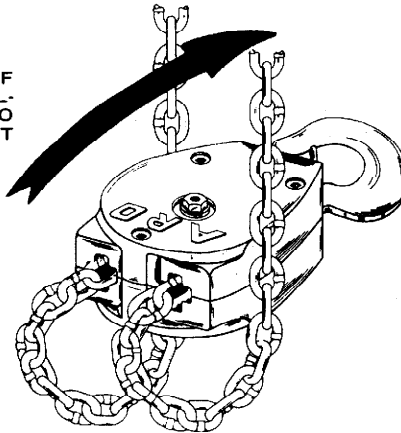

FIGURE 2



**WRONG**

APPEARANCE OF TWISTED CHAIN — ALTERNATING LINKS DO NOT FORM A STRAIGHT LINE



USE EXTREME CAUTION TO INSURE LOWER HOOK ASS'Y. HAS NOT BEEN FLIPPED THRU CHAIN RESULTING IN TWISTING OF CHAIN

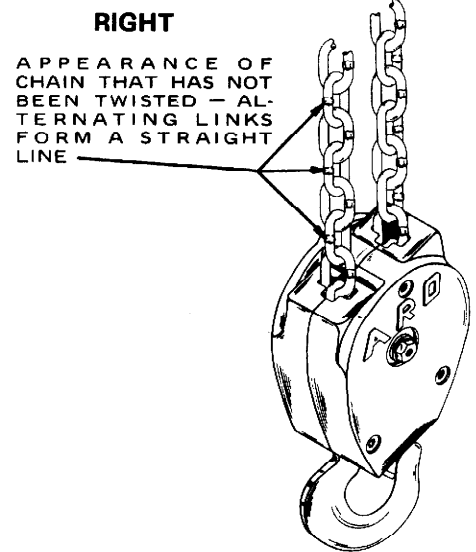

**RIGHT**

APPEARANCE OF CHAIN THAT HAS NOT BEEN TWISTED — ALTERNATING LINKS FORM A STRAIGHT LINE

FIGURE 3

Safe and efficient operation of your ARO hoist can be attained by observing proper operating, inspection and maintenance procedures. Allow only competent and qualified people to operate hoist and subject each hoist to a regular inspection and maintenance procedure. The qualified hoist operator must be carefully instructed in the safe operation of the hoist, including a study of the manufacturer's literature, and must thoroughly understand proper methods of hitching loads. The operator should have a good attitude regarding safety.

To aid in better understanding of proper and safe use of hoists: the publication "Overhead Hoists", ANSI B30.16-1981, can be purchased from the American Standards Institute, Inc., 1430 Broadway, N.Y., N.Y. 10018.

# INSPECTION AND MAINTENANCE

## INSPECTION

ARO recognizes the need for periodic inspection of hoist components as an important step in preventive maintenance. The type of application for a hoist varies so greatly, it is impractical to recommend an exact time-table for inspection of the hoist. Where hoist is subjected to continuous operation with capacity loads, it is recommended the unit be inspected daily to weekly. If the application is less demanding, the unit should be inspected weekly to monthly. In general, the frequency of inspection should be determined by the severity of the application.

The user of a hoist should be guided by any existing federal, state or local regulations governing the use, testing or inspection of the hoist.

The following points and areas are recommended for inspection:

### LOAD CHAIN AND ANCHORS

- a. Visually check for nicked, gouged, twisted, bent, corroded, rusted, worn or broken links. Check ends of chain where chain is anchored to hoist frame and where chain is fastened to lower hook. Check anchors and pins.
  - b. Check chain elongation with a vernier caliper as shown in figure 4. **IT IS NOT INFERRED** that a chain is safe prior to the occurrence of elongation of the chain. It is inferred **ONLY**, that when said elongation is evident, the chain must be replaced. Other factors, such as those mentioned as a visual check, may render chain unsafe long before replacement due to elongation is necessary.
- NOTE:** New chain should never be used on a worn pocketwheel. Replace chain and pocketwheel as a pair. Chain should also be replaced when replacing brake shoes.

### GEARS, BEARINGS AND SPROCKET

- a. Check condition of teeth on gears and motor shaft pinion.
- b. Check condition of sprocket teeth or pockets of pocketwheel.
- c. Check condition of bearings.
- d. Replace any worn or damaged parts.

### BRAKE

- a. Check brake linings and components.

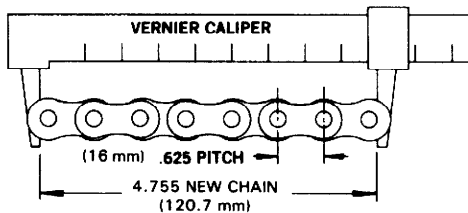

IF VISUAL CHECK REVEALS NO DEFECTS, PROCEED AS FOLLOWS:

LAY USED CHAIN ON FLAT SURFACE AND MEASURE OVER EIGHT (8) ROLLS, WHILE CHAIN IS PULLED TAUT, AS SHOWN. MEASUREMENT SHOULD BE TAKEN ON PORTION OF CHAIN WHICH HAS MOST PASSED OVER THE SPROCKET.

IF MEASUREMENT TAKEN IS 4.810 INCHES OR MORE, CHAIN SHOULD BE REPLACED.  
(122 mm)

FIGURE 4

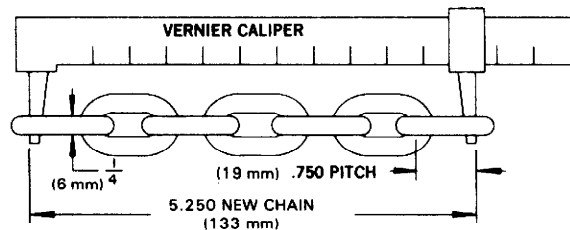

IF VISUAL CHECK REVEALS NO DEFECTS, PROCEED AS FOLLOWS:

LAY USED CHAIN ON FLAT SURFACE AND MEASURE BETWEEN SEVEN (7) LINKS AS SHOWN. MEASUREMENT SHOULD BE TAKEN ON PORTION OF CHAIN WHICH HAS MOST PASSED OVER THE POCKET WHEEL.

IF MEASUREMENT TAKEN IS 5.355 OR MORE, CHAIN SHOULD BE REPLACED.  
(136 mm)

## GENERAL MAINTENANCE

AIR HOISTS are made of precision parts and should be handled with reasonable care when servicing. Excessive pressure exerted by a holding device may cause distortion of a part. Apply pressure evenly when disassembling (or assembling) parts which have a press fit. When removing or installing bearings, apply pressure to the bearing race that will be press fit to the mating part; if this is not practiced, Brinelling of the bearing races may occur making replacement necessary. It is important that the correct tools and fixtures are used when servicing this air hoist.

DISASSEMBLY should be done on a clean work bench with a clean cloth spread to prevent the loss of small parts. After disassembly is completed, all parts should be thoroughly washed in a clean solvent, blown dry with air and inspected for wear levels, abuse and contamination. Double sealed or shielded bearings should never be placed

- b. Check brake operation.

**NOTE:** When replacement of brake shoes is indicated, they must be replaced as a pair. Also replace chain at this time.

### THROTTLE VALVE HEAD AND GEARS

- a. Check condition of valve body, valves and "O" rings on valves.
- b. Check condition of gear teeth and bearings.
- c. Replace any worn or damaged parts.

### HOOKS AND SUSPENSION

- a. Check upper and lower hooks and component parts for bent, worn, cracked, broken or otherwise damaged parts.
- b. On trolley suspended models, check conditions of trolley parts, trolley adapter and component parts. Replace any damaged parts.

### CORRECT HOOK OPENING

1-1/8" ON 1/4 & 1/2 TON MODELS  
(29 mm) (LOWER HOOKS)

1-1/4" ON UPPER & 1-TON LOWER HOOKS  
(32 mm)

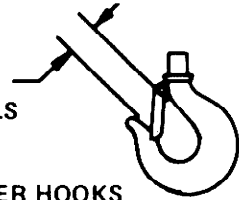

### AIR MOTOR

- a. Check end faces of rotor for roughness and blade slots for wear or burrs. A new blade should slide in and out of slots without binding.
- b. Check blades for wear, warpage or other damage.
- c. Check cylinder bore diameter for rough circular grooves from scoring. A badly scored cylinder cannot be restored by honing since it will only enlarge bore diameter, widening seal point between rotor and cylinder, hindering free exhaust of air and result in loss of speed and power.
- d. Check end plates for wear or scoring. Check bearings.
- e. Replace any excessively worn or damaged parts.

in solvent unless a good method of relubricating the bearing is available. Open bearings may be washed but should not be allowed to spin while being blown dry. When REPLACEMENT PARTS are necessary, consult drawing containing part.

BEFORE REASSEMBLING, lubricate parts where required. Use 33153 grease, or equivalent, in bearings. Use 36460 lubricant for "O" ring assembly. When assembling "O" rings or parts adjacent "O" rings, care must be exercised to prevent damage to the rubber sealing surfaces. A small amount of grease will usually hold steel balls and other small parts in place while assembling.

WHEN ORDERING PARTS, be sure to list PART NUMBER, PART NAME and MODEL NUMBER OF HOIST. USE ONLY GENUINE ARO REPLACEMENT PARTS.

REMOVAL

LINK CHAIN HOISTS — A new chain should never be used on a worn pocketwheel. Replace chain and pocketwheel as a pair. To remove chain; disconnect end of load chain from anchor lug on housing by removing screw (Y157-51) and washer (Y13-4-C). NOTE: Models employing a chain basket, remove chain stop from end of chain. Chain can be pulled thru housing by hand while holding brake open, by pulling (or pushing) on control arm (either end). On 1 ton models, disconnect opposite end of load chain from anchor bracket (41624) by removing nut (Y109-524) and bolt (41625). Remove chain stop and lower hook assembly.

ROLLER CHAIN MODELS — Disconnect end of load chain from anchor block (44686) by removing connecting link (33363). NOTE: Models employing a chain basket, remove chain stop (ring) from end of chain. Chain can be pulled thru housing by hand while holding brake open, by pulling (or pushing) on control arm (either end). On 1 ton models, disconnect opposite end of load chain from anchor bracket (37579) by removing bolt (37580) and anchor pin (34316). Remove chain stop and lower hook assembly.

INSTALLATION

LINK CHAIN MODELS — Position hoist in a vise or other suitable holding device (figure 5) and remove housing cap, brake spring and brake shoes. Turn brake wheel by hand to rotate pocketwheel while carefully feeding chain thru chain guide and around pocketwheel. Pull sufficient chain thru housing to allow end link of chain to be attached to anchor lug on housing.

**IMPORTANT NOTICE:** The link chain must be positioned around the pocketwheel so the weld on the standing links of chain face outward from pocketwheel (figure 5). ALSO, the end link of chain must be fed over pocketwheel so it will be positioned properly to permit attaching chain to anchor lug on housing without twisting of chain (figure 16).

**WARNING:** DO NOT attempt to feed chain over pocketwheel or sprocket by air power as chain will be pulled thru at a very fast rate.

ROLLER CHAIN MODELS — Remove housing cap, brake spring and brake shoes. Turn brake wheel by hand to rotate sprocket while carefully feeding chain thru guide and around sprocket. Pull sufficient chain thru housing to allow end link of chain to be attached to anchor block and anchor lug on housing.

**TO ASSEMBLE CHAIN TO LOWER BLOCK ON 1-TON MODELS, SEE PAGES 16 and 17 .**



**INSTALLING LOAD CHAIN**

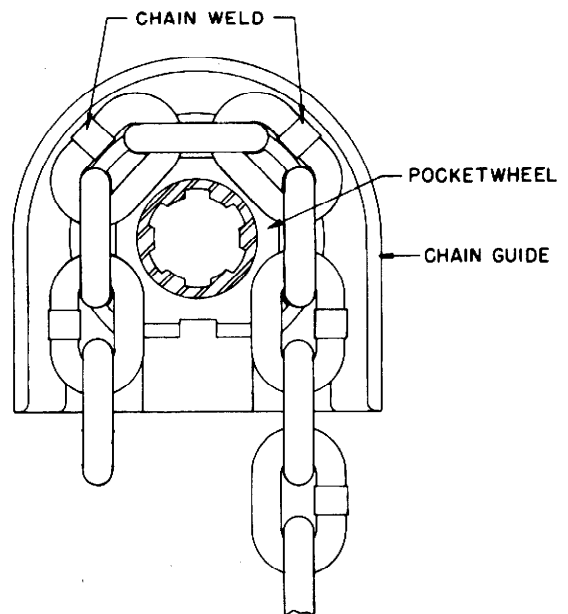

FIGURE 5

**BRAKE ADJUSTMENT**

To adjust brake, insert screwdriver thru hole in housing cap. Turn screw (37701) counterclockwise to tighten brake, clockwise to loosen brake.

Brake adjustment should be made with air turned on and with rated load attached to lower hook. Operate hoist to raise load applying slight pressure to pendent control. If load starts to lower before it is raised by motor, tighten brake until no slippage is evident. Care should be taken not to tighten brake more than necessary to hold load. If brake is too tight, it will cause erratic hoist control.

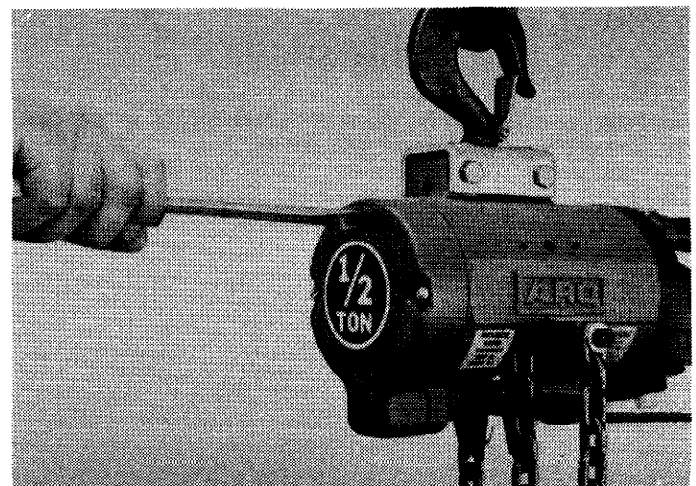

FIGURE 6

## DISASSEMBLY AND REASSEMBLY

To minimize the possibility of parts damage and for convenience, the steps for disassembly or reassembly listed on the following pages are recommended.

### REMOVAL OF HOIST

- a. Lower and disconnect load from hoist.
- b. Shut off air at source and operate hoist control to bleed air from hoist and line.
- c. Disconnect air hose at inlet swivel (on pendent control models, remove pendent control hoses also) and remove hoist from overhead suspension.
- d. If chain basket is being used, remove from hoist.
- e. Drain oil from reservoir in head.
- f. Remove trolley from hoist housing.
- g. Place hoist upside-down in vise and clamp on upper mounting on housing.
- h. If hoist is to be completely disassembled, it is recommended the load chain be removed. For removal of chain, see page 7.

### HEAD SECTION

- a. Remove roll pin (Y178-56) from gear (34022) and control rod (34021). NOTE: If head assembly is not to be disassembled, control rod may be removed with head, thereby making it unnecessary to re-time gear (34022) with throttle valves (see "Timing of Head" figure 7). To remove control rod with head, remove roll pin (Y178-55) from control arm (37719), remove roll pin (Y178-60) from brake block (34029) and remove brake block.
- b. Remove screws (Y154-54) and washers (Y14-10).
- c. Remove head assembly from housing.

### BRAKE AND GEARING SECTION

- a. Remove screws (Y19-113-C) and housing cap assembly.
- b. Slide brake spring (33281) part way off brake shoes (33387 or 33387-1) and remove spring with brake spring spreader (33541). This will release brake shoes and steel balls (Y16-10).
- c. Place a pin thru hole in brake wheel (33376) to keep from turning and remove nut (Y12-106) and washer (Y117-616). Remove brake wheel.
- d. Remove roll pin (Y178-60) from brake block (34029) and remove brake block from control rod (34021).
- e. Remove screws (Y99-41) and washers (30997) and remove gearing assembly.

### MOTOR SECTION

- a. After removal of head assembly, housing cap, nut (Y12-106) and washer (Y117-616); motor assembly may be removed from housing.

### HOUSING SECTION

- a. Follow disassembly procedures as outlined in head section, brake and gearing section and motor section.

For further disassembly of sections, see pages 10 thru 19.

## "TIMING OF HEAD"

### STEP 1

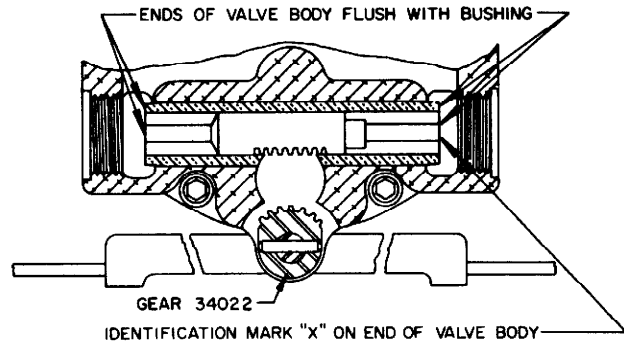

POSITION HOIST SO YOU ARE FACING END WITH AIR INLET.  
WITH VALVE PARTS AND GEAR 34030 REMOVED, PLACE VALVE BODY IN VALVE OPENING. INSERT FINGER IN EACH END OF VALVE OPENING AND ALIGN ENDS OF VALVE BODY WITH ENDS OF BUSHING.  
NOTE: VALVE BODY MUST BE INSTALLED WITH IDENTIFICATION MARK AS SHOWN.

### STEP 2

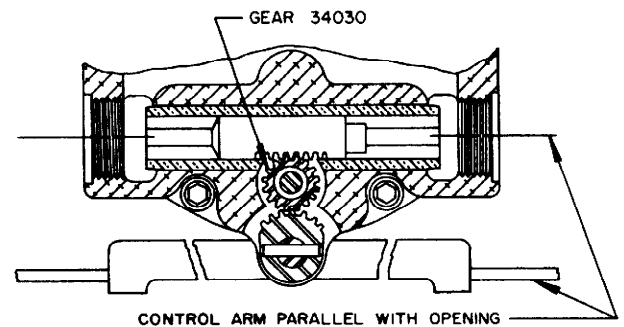

POSITION CONTROL ARM PARALLEL WITH OPENING.  
DROP GEAR 34030 INTO PLACE AND SECURE WITH SHAFT 34025 AND LOCK SCREW.

### STEP 3

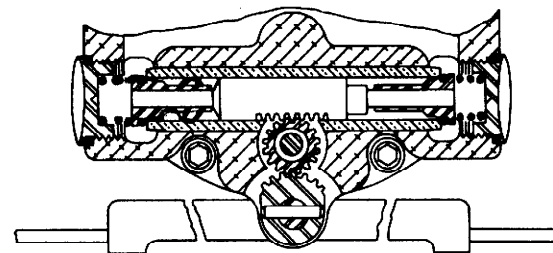

ASSEMBLE BALANCE OF VALVE PARTS.

FIGURE 7



TYPICAL CROSS SECTION

M50  
12

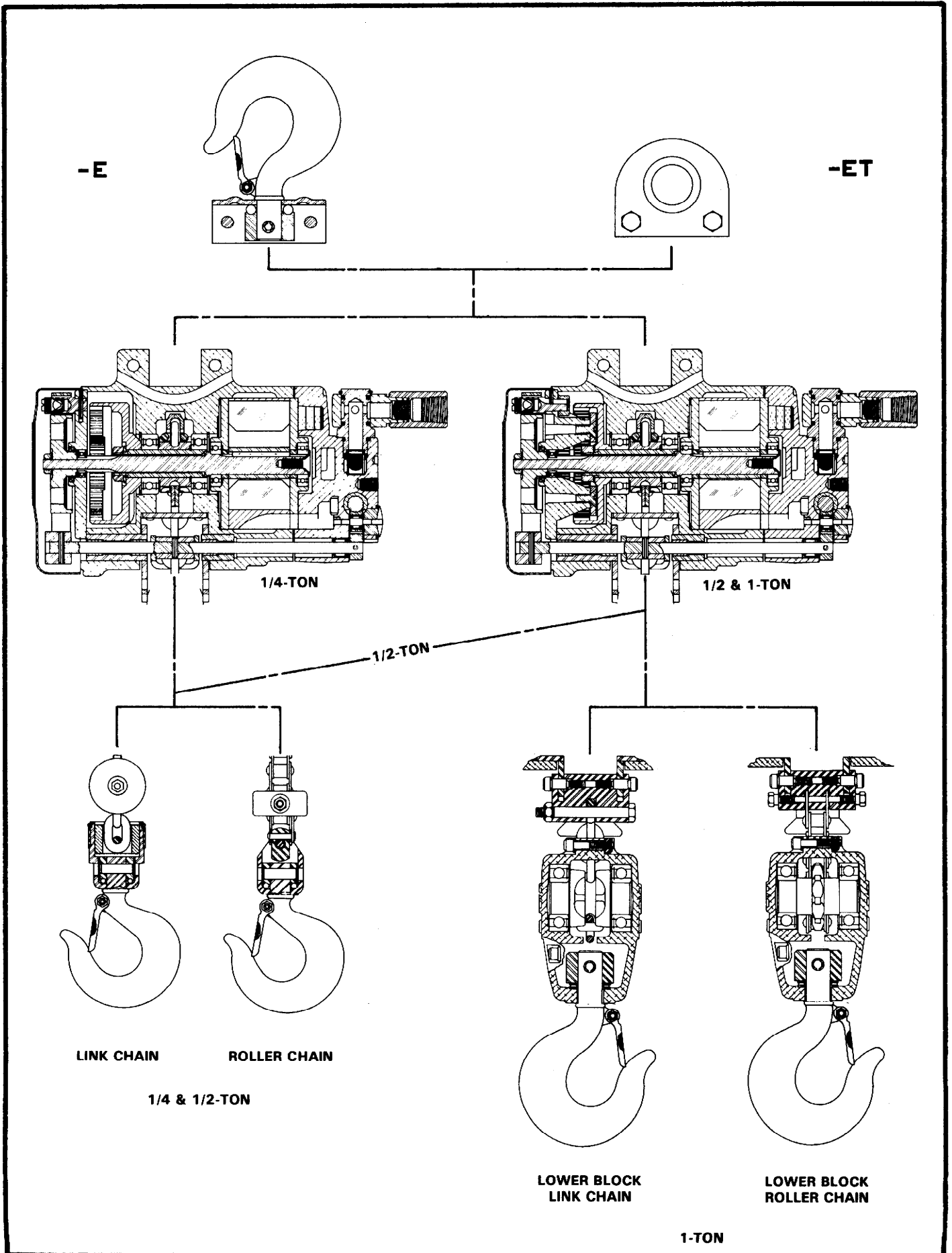

FIGURE 8

# HEAD SECTION

## DISASSEMBLY

- Remove head from housing as outlined on page 8.
- Remove lock screw (34024), gear (34030) and shaft (34025).
- Remove valve caps (34026), "O" rings (Y325-116) and springs (38966).
- Valves (33703) and (46079) with "O" rings (Y330-12) and valve body (37704) may now be removed from either end of head housing.
- Swivel assembly may be disassembled while mounted to head or removed from head. To disassemble, remove retaining ring (Y145-28), pull off swivel (46839) exposing "O" rings (Y325-115) and swivel body (33314).
- To remove oilite casting (33190), remove oil screw (30747) and washer (31389) on side of head. Insert screwdriver into opening and remove oilite casting.
- Muffler fillers (34028) and screen (33672) are exposed after removal of head from housing and may be removed.
- To remove regulator valve (41595), remove set screws (41598) and pull valves from housing.

## REASSEMBLY

- Assemble screen (33672) and fillers (34028) to head. Assuming other hoist components are assembled to housing, assemble head to housing with gasket (41623). Secure with washers (Y14-10) and screws (Y154-54).
- Assemble "O" rings (Y325-17) and (Y325-115) and screen (46072) to swivel body and assemble to head. Assemble swivel to swivel body and secure with retaining ring (Y145-28). Assemble screen (31648) and adapter (46211) to swivel.
- Assemble oilite casting (33190), screw (30747) with washer (31389) and regulator valves (41595) with "O" rings (Y325-11) to head.

NOTE: Assemble valves to head with slot in valve positioned to accept set screw. Secure valves with set screws (41598). After complete assembly of hoist, loosen set screw and adjust valve for desired rate of lift and descent. See pages 4 and 5.

- With gear (34022) and control rod assembled to housing, assemble valve parts as shown in figure 7, page 8.

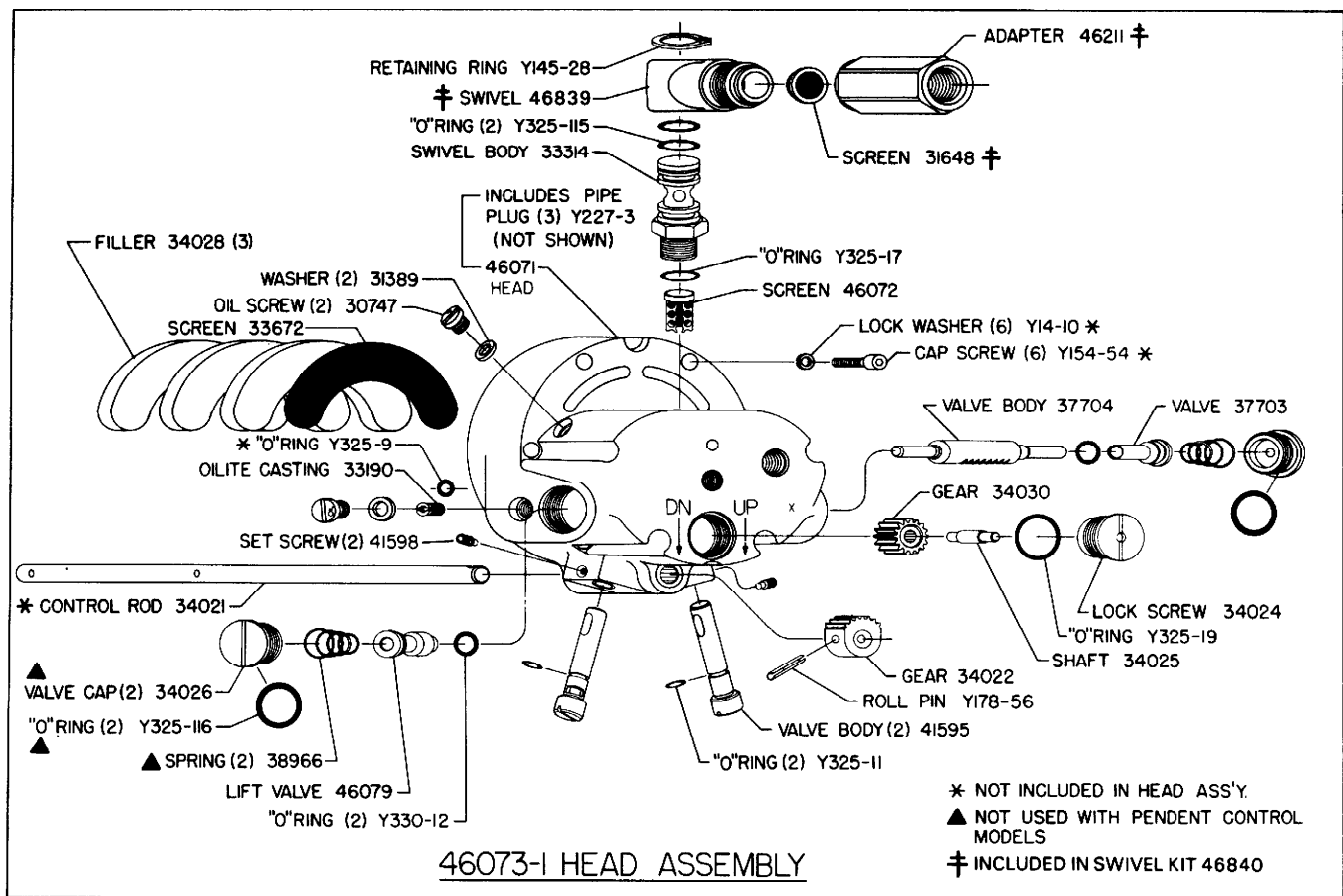

FIGURE 9

## DISASSEMBLY

- a. Remove housing cap, brake spring, brake wheel and components as outlined on page 8.
- b. On 1/4 ton models, remove nuts (38910), releasing gear and bearing assemblies.
- c. On 1/2 and 1 ton models, remove screws (Y194-44), nuts (33368), washers (Y1-516) and bolts (33369), releasing support ring and gear assemblies.
- d. Bearing (36546) and grease seal (37706) should be removed only for replacement.

## REASSEMBLY

**NOTE:** Lubricate gears and bearings liberally with ARO 33153 grease when assembling.

- a. Assemble grease seal (37706) and bearing (36546) to end plate, if removed.

- b. On 1/4 ton models, assemble bearings (32325) and retaining rings (38908) to idler gears (38905) and secure to end plate with screws (38907) and nuts (38910).
- c. On 1/2 and 1 ton models, assemble wear plates (45909), gear assemblies and bushings to end plate and secure with support ring, screws (Y194-44), bolts (33369), washers (Y1-516) and nuts (33368).
- d. Assemble end plate to housing and secure with washers (30997) and screws (Y99-41).
- e. Assemble brake wheel (33376) to splined end of motor spindle and secure with washer (Y117-616) and nut (Y12-106).
- f. Assemble steel balls (Y16-10) and screw (37701) into bracket. Position brake shoes (33387 or 33387-1) over brake wheel and assemble brake spring (33281) over shoes, using brake spring spreader (33541).
- g. Assemble housing cap over brake and secure with screws (Y19-113-C). See "Brake Adjustment", page 7.

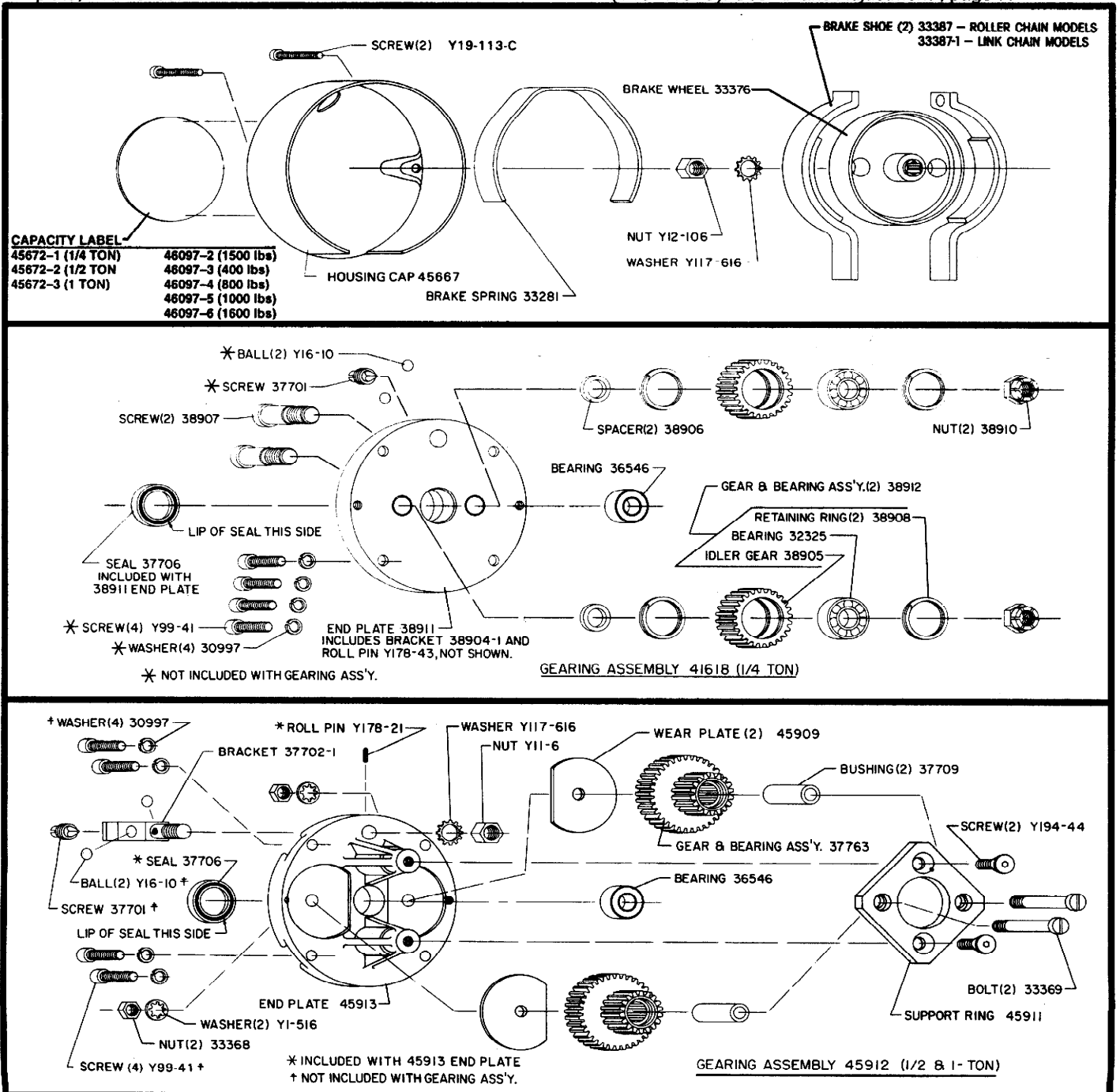

FIGURE 10

## MOTOR SECTION

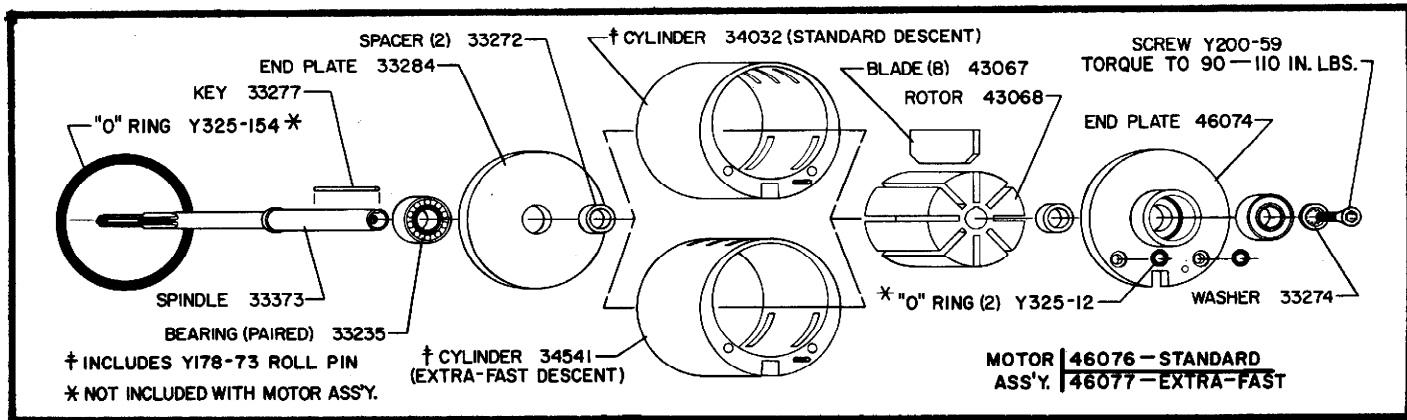

FIGURE 11

### DISASSEMBLY

- Remove motor from housing as outlined on page 8.
- Remove screw (Y200-59) and washer (33274). Motor will now come apart.

### REASSEMBLY

- Assemble bearings (33235) and spacers (33272) into end plates. NOTE: Bearings (33235) are paired flush face bearings, shielded on one side. The open or unshielded side must be installed facing the end plate. Lubricate bearings with 33153 grease when assembling.

- Assemble end plate (33284) together with bearing and spacer on large end of spindle shaft (33373) and slide up to boss on shaft.
- Assemble key (33277) into groove in spindle and assemble rotor with groove aligned with key on spindle.
- Assemble cylinder over rotor to end plate and assemble blades (43067) to rotor.
- Assemble end plate (46074) together with spacer and bearing. Secure with washer (33274) and screw (Y200-59). Hold spindle in a suitable holding device, being careful not to damage splines or threads on end of spindle.
- Assemble "O" rings (Y325-12) into end plate.
- Assemble motor with "O" ring (Y325-154) into housing.

## HOUSING SECTION

### DISASSEMBLY

- Remove plate (33318) on link chain models; remove chain stripper (33319) on roller chain models.
- Place brass or wood block in sprocket cavity to prevent turning of sprocket shaft and remove nut (33280), washer (Y1-966) and gear.
- Remove retaining ring (Y147-18) from "motor end" of housing.
- Sprocket shaft and bearing (33236) may now be removed thru "motor end" of housing.
- Remove chain guide (35861) and pocketwheel (37571) on link chain models. On roller chain models, to remove chain guide (34991), remove cap screws (Y154-54) and washers (Y14-10) from housing.
- Remove retaining ring (Y147-18) and bearing (33236) from "brake end" of housing.

### REASSEMBLY

#### LINK CHAIN MODELS -

- Insert pocketwheel (37571) into chain guide (35861) and place in housing. NOTE: Pocketwheel must be installed with 1.250 diameter counterbore facing away from "brake end" of housing. Secure plate (33318) to housing with sems fasteners (33330).
- Assemble bearing (33236) and retaining ring (Y147-18) into "brake end" of housing.
- Assemble retaining ring (Y145-28) into groove in shaft (34985) and assemble bearing (33236) on end of shaft with retaining ring.
- Assemble shaft, with bearing and retaining ring thru opening at "motor end" of housing. Insert shaft thru pocketwheel and thru bearing in "brake end" of housing. Assemble retaining ring (Y147-18) into housing.
- Assemble gear (33374) to shaft and secure with washer (Y1-966) and nut (33280).
- Assemble brake block (34029) to control rod (34021) and secure with roll pin (Y178-60).

- Assemble hangers (37585) and control arm (37719) to housing (NOTE: Assemble control arm in housing with arms for mounting control chains pointing towards air inlet) and insert control rod thru housing, hangers and control arm. Secure control rod and arm with roll pin (Y178-55).
- On 1 ton models, assemble anchor bracket (41624) to hangers (37585) and secure with washers (37587) and anchor bolts (37586).
- For installation of load chain, see page 7.

#### ROLLER CHAIN MODELS -

- Insert chain guide (34991) into housing and secure with washers (Y14-10) and cap screws (Y154-54).
- Assemble bearings (33236) and retaining ring (Y147-18) into "brake end" of housing.
- Assemble bearing (33236) on sprocket (33375) and assemble into housing thru "motor end" with threaded end of sprocket thru bearing in "brake end" of housing.
- Assemble gear (33374) to shaft and secure with washer (Y1-966) and nut (33280).
- Secure chain stripper (33319) to housing with sems fasteners (33330).
- Assemble brake block (34029) to control rod (34021) and secure with roll pin (Y178-60).
- Assemble hangers (37585) and control arm (37719) to housing (NOTE: Assemble control arm in housing with arms for mounting control chains pointed towards air inlet) and insert control rod thru housing, hangers and control arm. Secure control rod and arm with roll pin (Y178-55).
- On 1 ton models, assemble anchor bracket (37579) to hangers (37585) and secure with washers (37587) and anchor bolts (37586).
- For installation of load chain, see page 7.

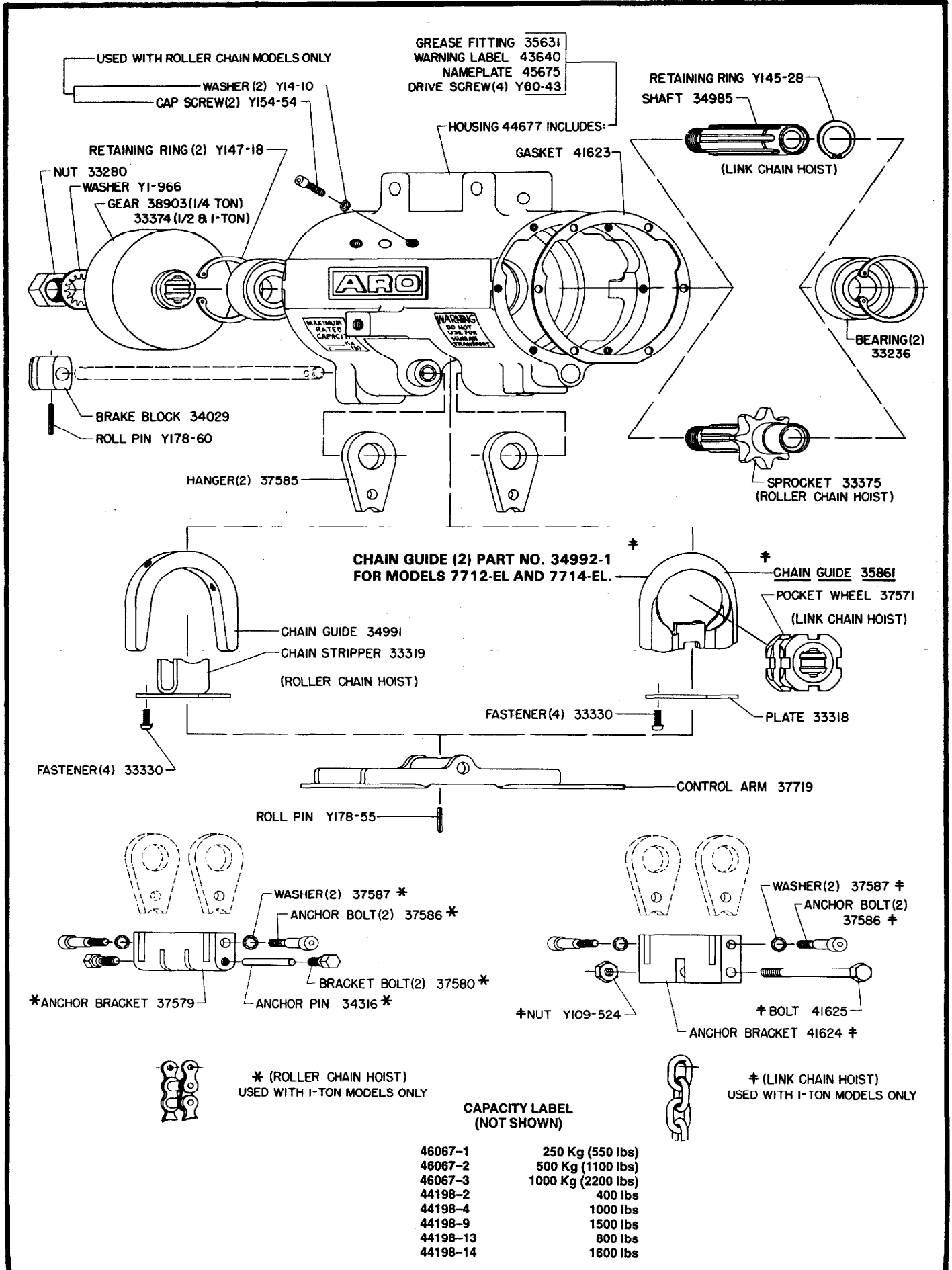

FIGURE 12

## UPPER HOOK SECTION

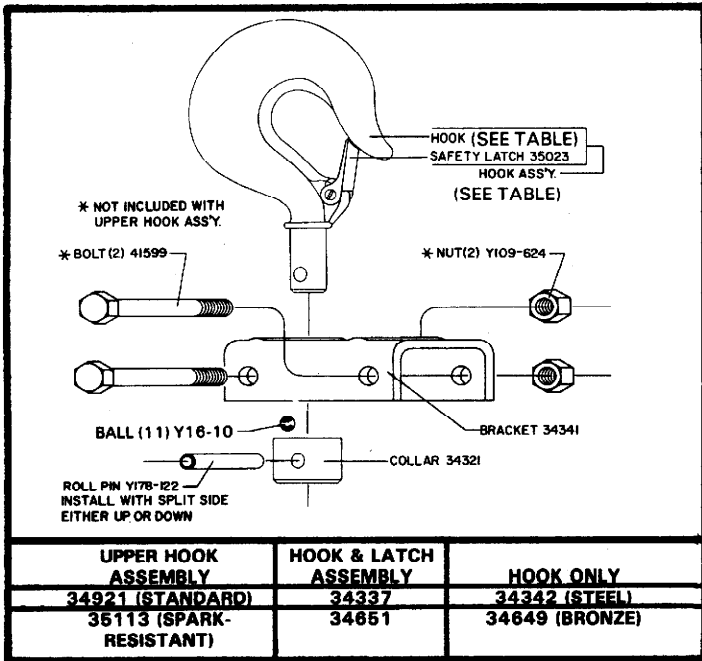

FIGURE 13

### DISASSEMBLY

- To remove upper hook assembly from housing, remove nuts (Y109-624) and bolts (41599).
- To disassemble hook assembly, drive out roll pin (Y178-122) from collar (34321).
- Removing collar will release steel balls and bracket from hook and latch assembly.

### REASSEMBLY

- To assemble steel balls to collar, apply a liberal amount of grease in groove of collar and place steel balls into groove.
- Place bracket in a holding device with flanges down. Insert hook thru bracket and slip collar with steel balls over end of hook. Secure with roll pin.
- Assemble to housing and secure with bolts and nuts.

NOTE: Assemble roll pin with split side pointing directly UP or DOWN. Insure safety latch is properly assembled to hook.

## LOWER HOOK SECTION

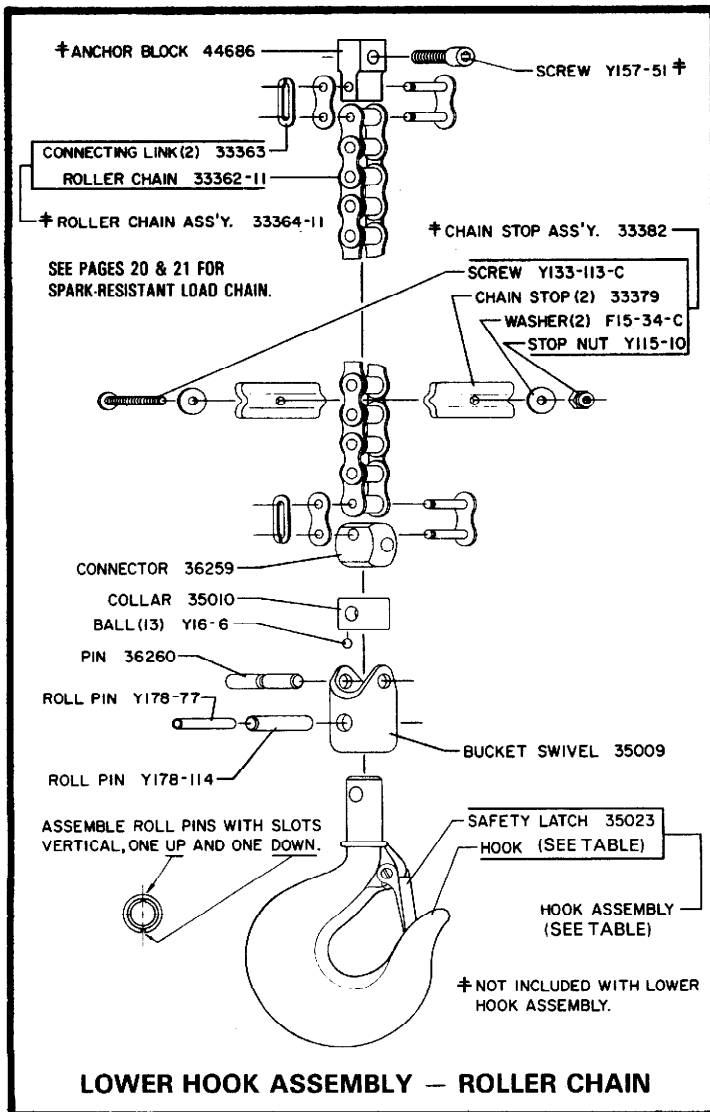

FIGURE 14

## 400# & 800# ROLLER CHAIN MODELS

### DISASSEMBLY

- Remove connecting link (33363). Remove pin (36260), releasing connector (36259).
- To disconnect hook from bucket swivel (35009), drive out roll pins (Y178-114 and Y178-77), releasing collar (35010) and steel balls (Y16-6).

### REASSEMBLY

- Assemble steel balls (Y16-6) to collar (35010), applying a liberal amount of grease in groove of collar to hold steel balls in place and also for lubrication.
- Place bucket swivel (35009) in holding device with opening for collar pointing down. Place hook and latch assembly thru swivel and slip collar with steel balls over end of hook and secure with roll pins (Y178-114 and Y178-77).
- Assemble connector (36259) to bucket swivel (35009) and secure with pin (36260). Assemble chain to connector and secure with connecting link.

NOTE: Install roll pins with slots vertical, one UP and one DOWN, figure 14. Insure safety latch is properly assembled to hook.

LOWER HOOK ASSEMBLY	HOOK & LATCH ASS'Y.	HOOK ONLY
33381-1 (STANDARD)	35005	35006 (STEEL)
34655-1 (SPARK-RESISTANT)	35007	35008 (BRONZE)

1/4 AND 1/2 TON LINK CHAIN MODELS

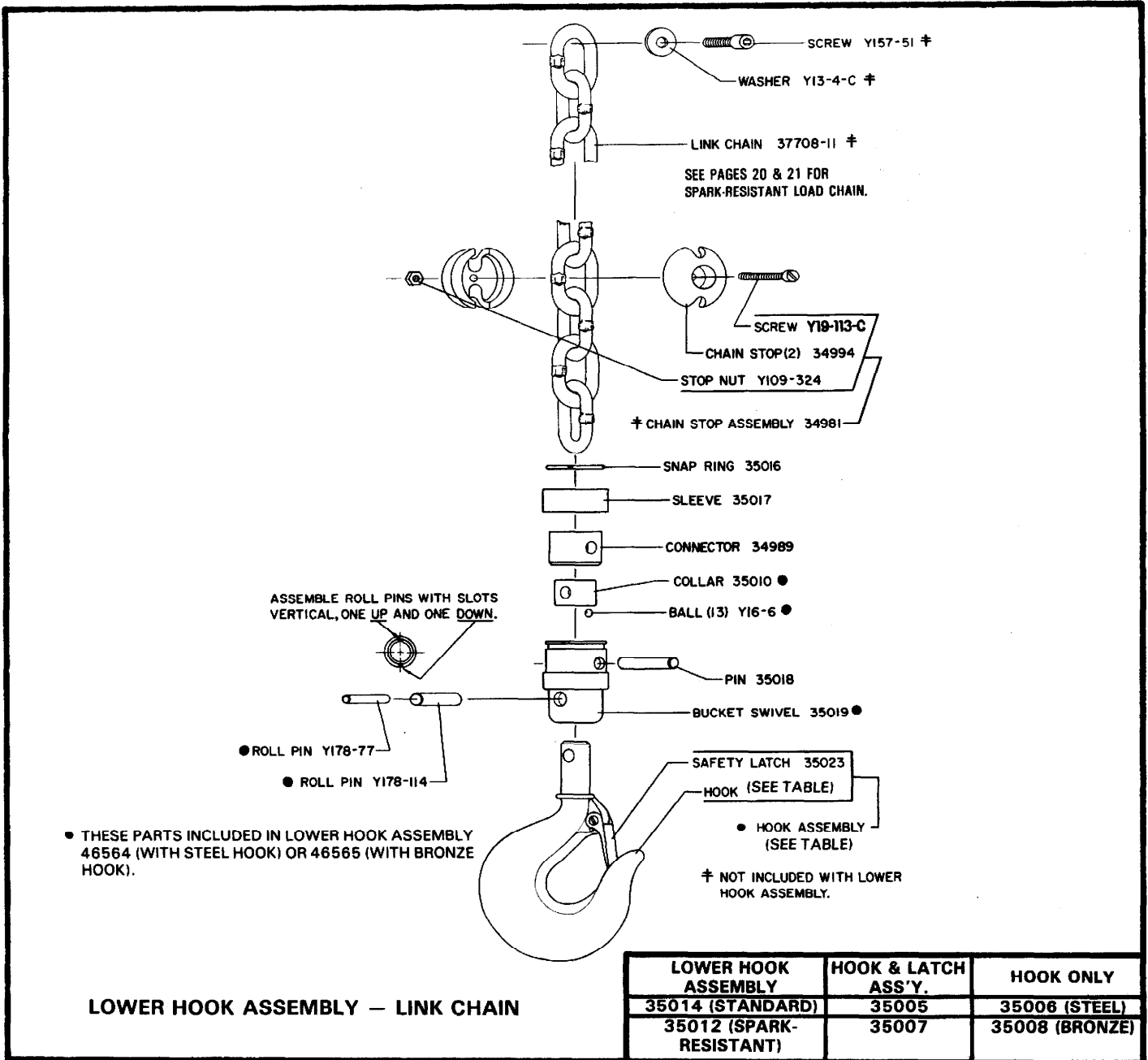

FIGURE 15

**DISASSEMBLY**

- Remove snap ring (35016) and sleeve (35017). Drive out pin (35018), releasing chain and connector (34989).
- To disconnect hook from bucket swivel (35019), drive out roll pins (Y178-114 and Y178-77), releasing collar (35010) and steel balls (Y16-6).

**REASSEMBLY**

- Assemble steel balls (Y16-6) to collar (35010), applying a liberal amount of grease in groove of collar to hold steel balls in place and also to lubricate balls.
- Place bucket swivel (35019) in a suitable holding device with open-

- ing for collar pointing down. Place hook and latch assembly thru bucket swivel and slip collar with steel balls over end of hook and secure with roll pins (Y178-114 and Y178-77).
- Place bucket swivel in holding device with hook down. Insert connector (34989) in proper position in swivel, place snap ring (35016) and sleeve (35017) over end of chain. Place chain in connector and secure chain and connector to swivel with pin (35018).
- Slip sleeve (35017) over end of swivel and secure with snap ring (35016).

NOTE: Install roll pins with slots vertical — one UP and one DOWN. Insure safety latch is properly assembled to hook.

# LOWER HOOK SECTION

## 1 TON LINK CHAIN MODELS

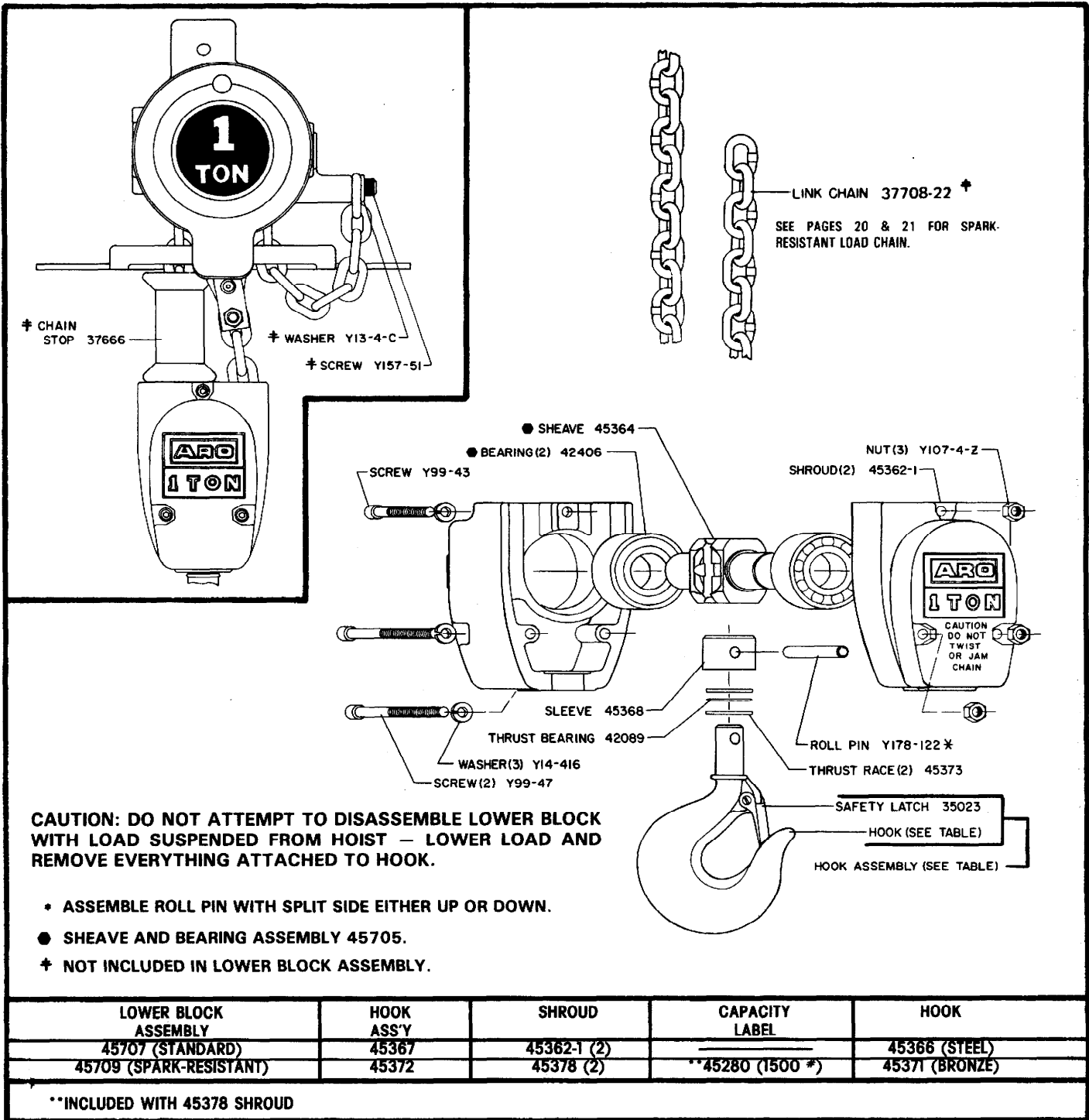

FIGURE 16

### DISASSEMBLY

- a. Remove screw (Y99-43) and two (2) screws (Y99-47), lock washers (Y14-416) and nuts (Y107-4-Z).
- b. Pull shroud apart releasing hook and components. Bearings (42406) are pressed on shaft of sheave (45364).
- c. To remove thrust bearing from hook shank, remove roll pin (Y178-122) and sleeve (45368).

### REASSEMBLY

- a. Lubricate thrust bearing liberally with grease 33153 or equivalent and assemble to shank of hook. Assemble sleeve (45368) to hook

- and secure with roll pin (Y178-122). NOTE: Assemble roll pin to hook with split side vertical with hook (either up or down).
- b. Pack bearings (42406) with grease 33153 and assemble to sheave with shielded side going on shaft first (shielded side towards sheave).
- c. Assemble sheave and hook into one half of shroud, insuring thrust bearing and race are properly seated in shroud.
- d. Feed load chain around sheave. CAUTION - Insure chain is not twisted and that welded side of links face away from sheave - see figure 5 and inset above.
- e. Assemble other half of shroud and secure shroud with screws, washers and nuts as shown, tightening securely.



**LOWER HOOK SECTION  
1600# ROLLER CHAIN MODELS**

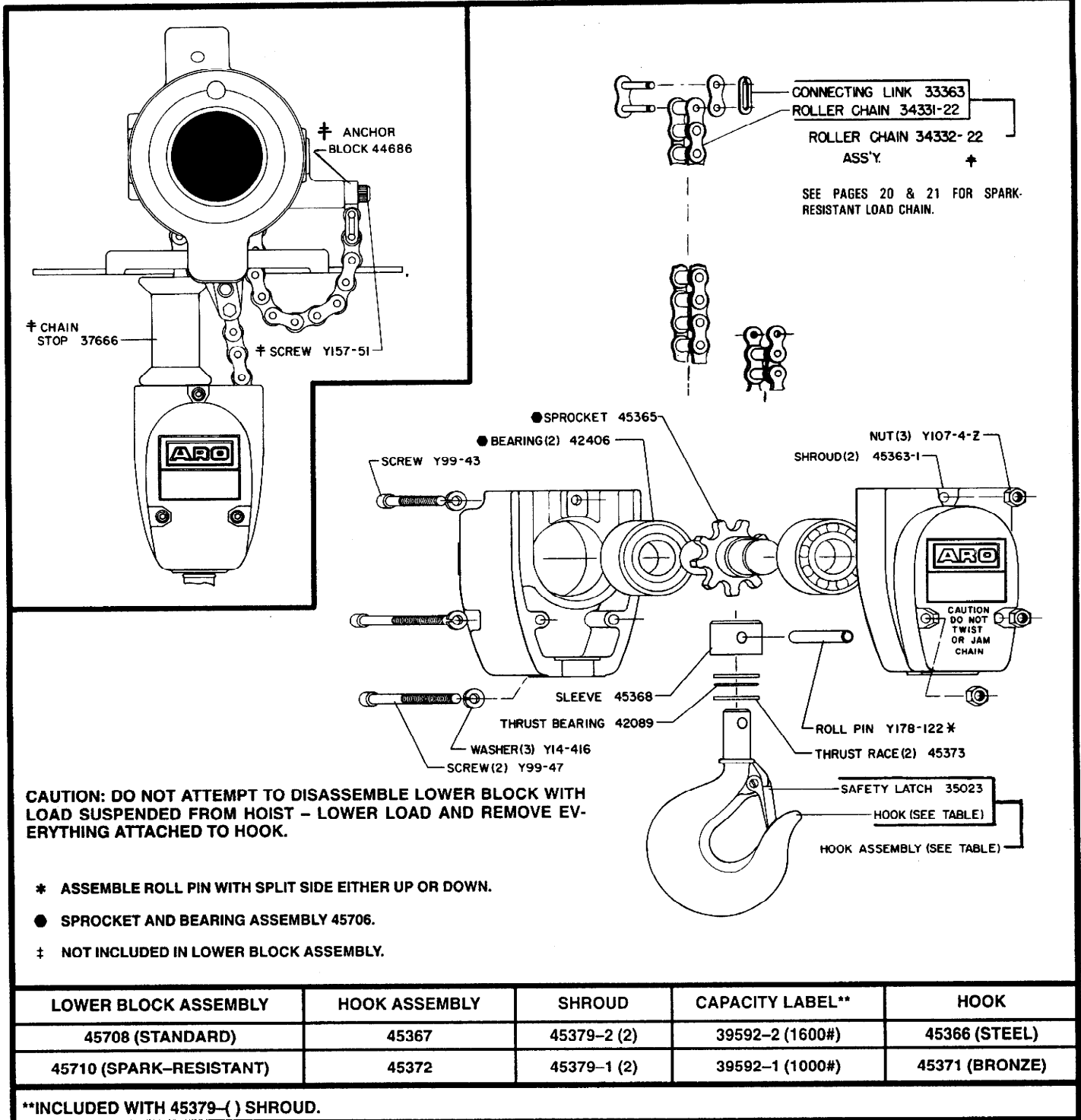

FIGURE 17

**DISASSEMBLY**

- Remove screws (Y99-43) and two (2) screws (Y99-47), lock washers (Y14-416) and nuts (Y107-4-Z).
- Pull shroud apart, releasing hook and components. Bearings (42406) are pressed on shaft of sprocket (45365).
- To remove thrust bearing from hook shank, remove roll pin (Y178-122) and sleeve (45368).

**REASSEMBLY**

- Lubricate thrust bearing liberally with ARO 33153 grease, or equivalent, and assemble to shank of hook. Assemble sleeve

(45368) to hook and secure with roll pin (Y178-122). NOTE: Assemble roll pin to hook with split side vertical with hook (either up or down).

- Pack bearings (42406) with ARO 33153 grease and assemble to sprocket, with shielded side going on shaft first (shielded side towards sprocket).
- Assemble sprocket and hook into one half of shroud, insuring thrust bearing and race are properly seated in shroud.
- Feed load chain around sprocket. CAUTION: Insure chain is not twisted.
- Assemble other half of shroud and secure shroud with screws, washers and nuts as shown, tightening securely.

## CONTROLS SECTION

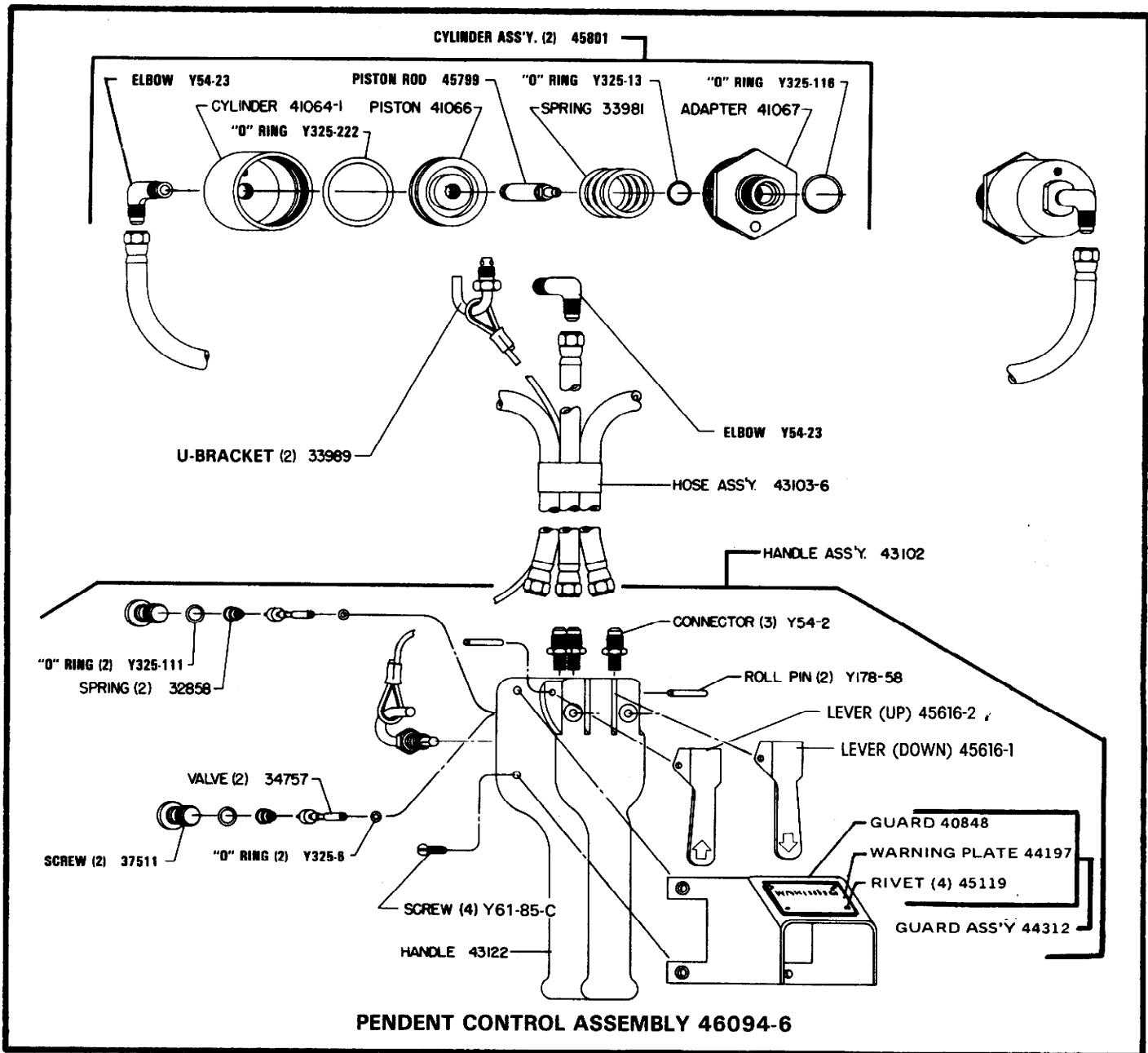

**FIGURE 18  
PENDENT CONTROL 3-HOSE SYSTEM**

### DISASSEMBLY

- a. To remove from hoist, shut off air and disconnect hoses from cylinder assemblies and from head.
- b. Remove "U" bracket (33989) from head, releasing cable.
- c. To disassemble cylinders, unscrew and remove from head.
- d. Remove adapter (41067), releasing spring, piston, piston rod and "O" ring.
- e. To disassemble control handle, remove screws (37511) with "O" rings (Y325-111), releasing spring (32858) and valve (34757) with "O" rings (Y325-6).

### REASSEMBLY

- a. Assemble "O" ring (Y325-13) into adapter (41067).
- b. Assemble piston rod (45799) and "O" ring (Y325-222) to piston (41066) and assemble with spring (33981) into cylinder (41064-1). Secure with adapter (41067).
- c. Assemble with "O" ring (Y325-116) to hoist.
- d. To reassemble control handle, reverse disassembly procedure.

### ASSEMBLY OF CONTROLS TO HOIST

On pendent control models, control hoses must be attached to cylinder on head as follows: Facing air inlet of hoist, the hose to "DOWN" lever of control must be connected to cylinder on left hand side of head. Hose to "UP" side of control must be connected to right hand side of the head.

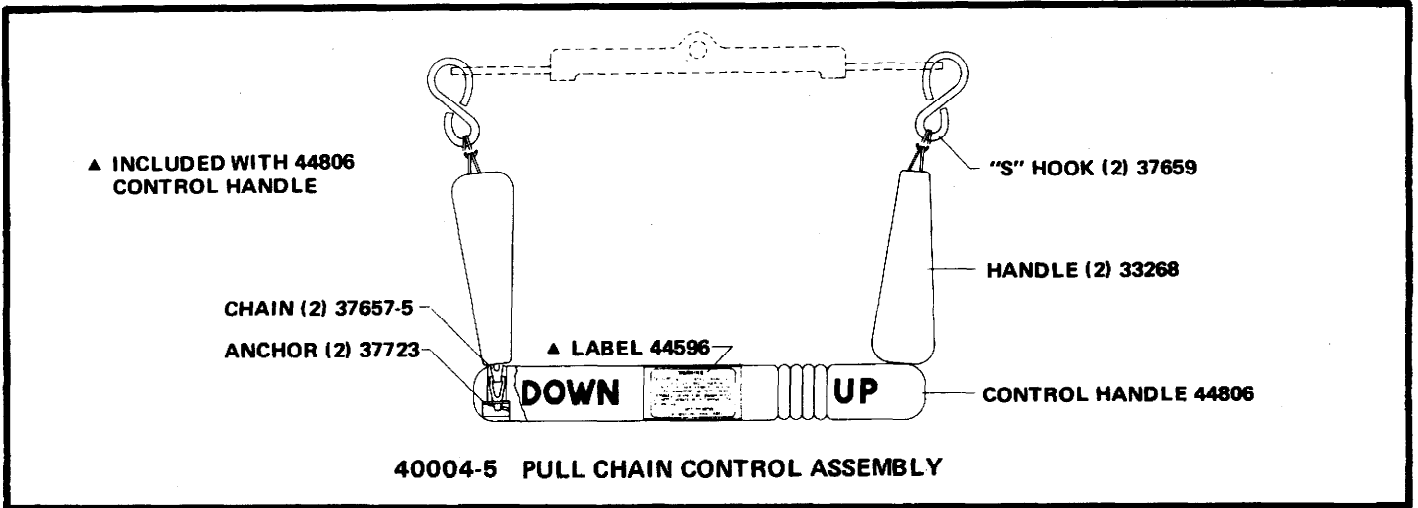

FIGURE 19

On pull chain control models, control chains must be installed as follows: Facing air inlet end of hoist (with hoist in an upright position), chain attached to "UP" end of control handle must be attached to

right end of control arm. Chain attached to "DOWN" end of control handle must be attached to left end of control arm.

PENDENT CONTROL

3-HOSE SYSTEM

THE HOIST WILL ALWAYS CEASE OPERATION WHEN OPERATOR RELEASES THE PENDENT CONTROL. IF ANY HOSE (AIR INLET OR PENDENT CONTROL HOSES) SHOULD BECOME CUT OR RUPTURED – 1) RELEASE PENDENT CONTROL. 2) SHUT OFF AIR SUPPLY AND REPLACE HOSE.

TO OPERATE HOIST IF HOSE SHOULD RUPTURE, BE GUIDED BY THE FOLLOWING:

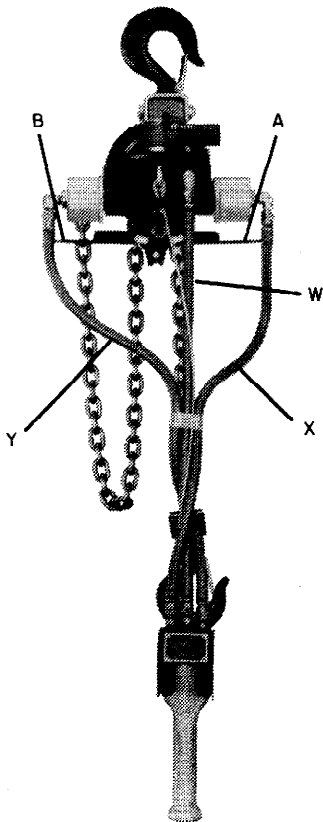

FIGURE 20

AIR INLET HOSE CUT OR RUPTURED:

TO LOWER LOAD – Load may be lowered by manually operating control arm. Pull down on control arm at "B". See WARNING note below.

IF HOSE "W" IS CUT OR RUPTURED:

TO LOWER LOAD – Load may be lowered by manually operating control arm. Pull down on control arm at "B". See WARNING note below.

IF HOSE "X" IS CUT OR RUPTURED:

TO LOWER LOAD – Load may be lowered by depressing "DOWN" lever of pendent control.

IF HOSE "Y" IS CUT OR RUPTURED:

TO LOWER LOAD – Load may be lowered by manually operating control arm. Pull down on control arm at "B". See WARNING note below.

TO RAISE LOAD – Load may be raised by depressing "UP" lever of pendent control.

**WARNING:** Exercise care when operating control arm to lower load as load will be lowered at a very fast rate.

# SPARK-RESISTANT HOIST SECTION

MODELS Hook Mounting	CAPACITY (LBS)	LOAD CHAIN			HOOKS	CONTROLS	MAX. LIFT RATE AT 90 P.S.I.	MAX. DESCENT RATE AT 90 P.S.I.
		TYPE	NUMBER	LIFT				
7712-E	400	Stainless, Roller	34043-11	10' (3.0 m)	Bronze	Pull Chain	40 F.P.M.	40 F.P.M.
7712-EL	550	Stainless, Link	39489-11	10' (3.0 m)	Bronze	Pull Chain	50 F.P.M.	70 F.P.M.
7714-E	1000	Stainless, Roller	35109-22	10' (3.0 m)	Bronze	Pull Chain	10 F.P.M.	10 F.P.M.
7714-EL	1500	Stainless, Link	39489-22	10' (3.0 m)	Bronze	Pull Chain	16 F.P.M.	16 F.P.M.

NOTE: For models with trolley adapter in place of upper hook, add the letter "T" to model number. Example - 7712-ET or -ELT would be supplied with trolley adapter in place of upper hook.

The hoists listed in the chart above are furnished with load chain made of stainless steel. The top and bottom hooks of these hoists are bronze, with snaps.

Other components of the 400 lb. capacity spark-resistant hoists are comparable to the standard 1/2 ton models, and the 1000 lb. capacity spark-resistant hoist components are comparable to the standard 1 ton models, but the rates of lift and descent are modified. All rates of lift and descent outlined here are maximum of 90 p.s.i. The 400 lb. capacity, stainless roller chain hoists have a rate of lift and descent of approximately 40 feet per minute. The 550 lb. capacity, stainless steel link chain hoists have a rate of lift of 50 feet per minute and 70 feet per minute on descent. The 1000 lb. capacity hoists have a rate of lift and descent at approximately 10 feet per minute. The 1500 lb. capacity hoists have a rate of lift and descent at approximately 16 feet per minute.

SPECIAL NOTE: Spark-resistant models are shipped from the factory with valves (41595) pre-set for maximum rates of lift and descent and are secured by set screws (41627-1). DO NOT ADJUST OR REMOVE VALVES (41595) on these models. If head

assembly is replaced for service, valves (41595) must be adjusted for the following rates of lift and descent.

400 LB. and 550 LB. CAPACITY HOISTS - Rate of lift with maximum throttle opening with a 500 lb. load shall be:

Roller chain models - 40 ft/min. maximum.

Link chain models - 50 ft/min. maximum.

Rate of descent with maximum throttle opening and a 500 lb. load shall not exceed:

Roller chain models - 40 ft/min.

Link chain models - 70 ft/min.

1000 LB. CAPACITY HOIST - Rate of lift and descent with maximum throttle opening with 1200 lb. load shall not exceed 10 ft/min.

1500 LB. CAPACITY HOIST - Rate of lift and descent with maximum throttle opening with a 1500 lb. load shall not exceed 16 ft/min.

Air inlet adapter (46212) must be used with the 1000 lb. capacity hoists.

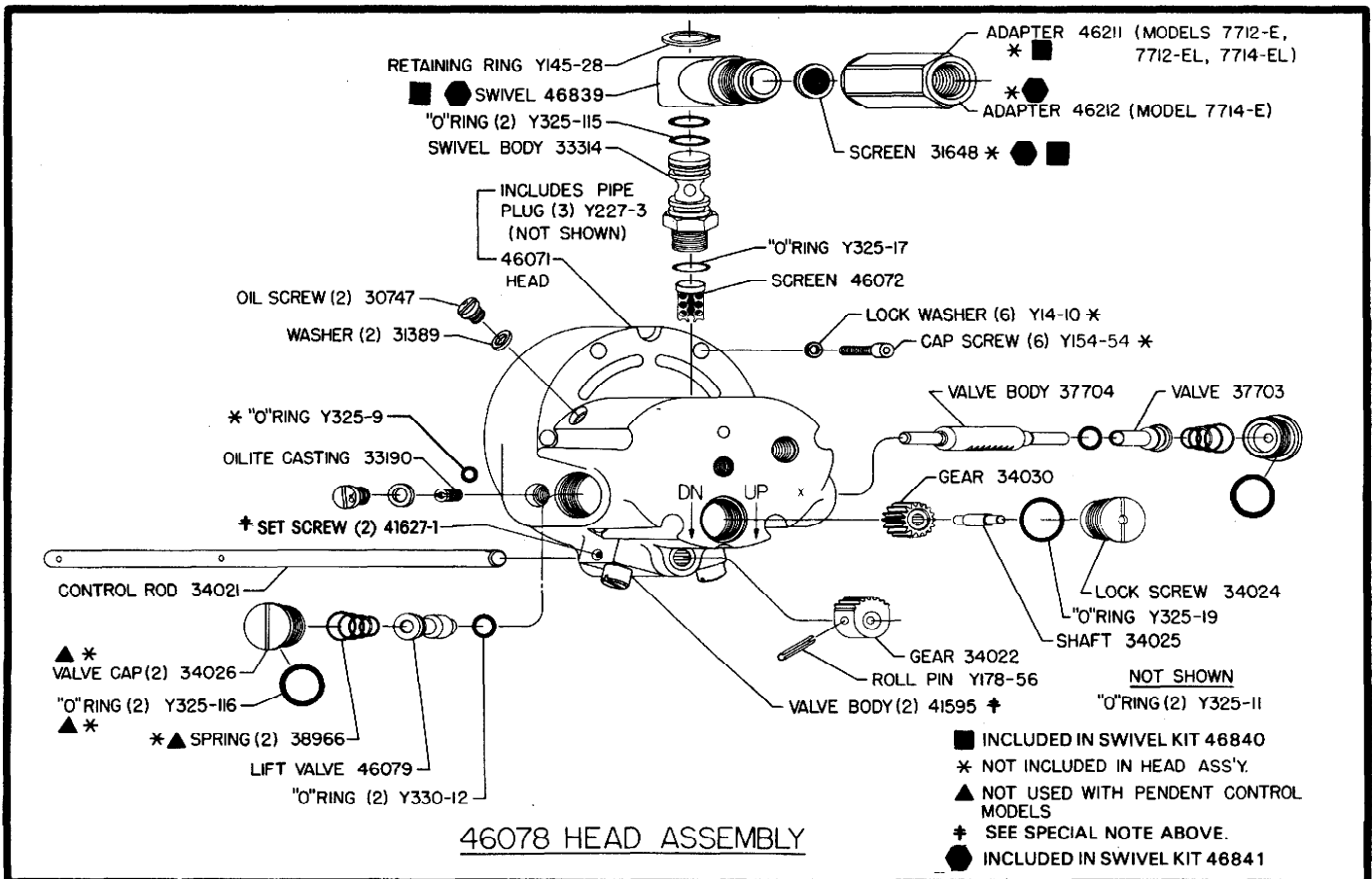
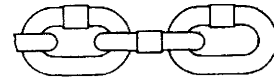

FIGURE 21

**SPARK-RESISTANT HOIST CHAIN  
LOAD CHAIN**  
STAINLESS STEEL LINK CHAIN 39489-()  
FOR 250 kg (550 lb.) AND 1500 lb. CAPACITY HOIST

Dash number indicates exact length in feet. For 550 lb. capacity hoists, order lift footage and add one extra foot for assembly. For 1500 lb. capacity hoists, order twice the lift footage and two extra feet for assembly and specify by corresponding dash number. Example: 39489-10, the dash 10 indicates 10 feet of chain.



**STAINLESS STEEL ROLLER CHAIN 34043-()**  
FOR 400 lb. CAPACITY HOIST

Dash number indicates exact length in feet. Example: 34043-10, the dash 10 indicates 10 feet of chain. When ordering, figure desired lift footage, add one extra foot for assembly and specify by corresponding dash number. Part number 34043-() includes two (2) connecting links (34042).

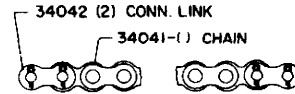

**STAINLESS STEEL ROLLER CHAIN 35109-()**  
FOR 1000 lb. CAPACITY HOIST

Dash number indicates exact length in feet. Example: 35109-20, the dash 20 indicates 20 feet of chain. When ordering, figure twice the desired lift footage, add two extra feet for assembly and specify by corresponding dash number. Part number 35109-() includes one (1) connecting link (34042).

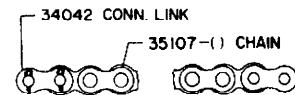

**ACCESSORIES SECTION  
PIPED EXHAUST**

Exhaust from the air motor normally escapes into the room atmosphere, however, exhaust can be piped out of the room. The hoist can be furnished, at extra cost, with a modified head for piped exhaust. An exhaust hose, 1/2" (12 mm) diameter recommended, can then be attached to this outlet and air can be vented at any remote point. Piped exhaust is highly desirable in applica-

tions involving food processing, chemicals or other processes where atmospheric purity must be maintained. It is also preferred for its low noise level characteristics.

When ordering, specify model number and add "with piped exhaust".

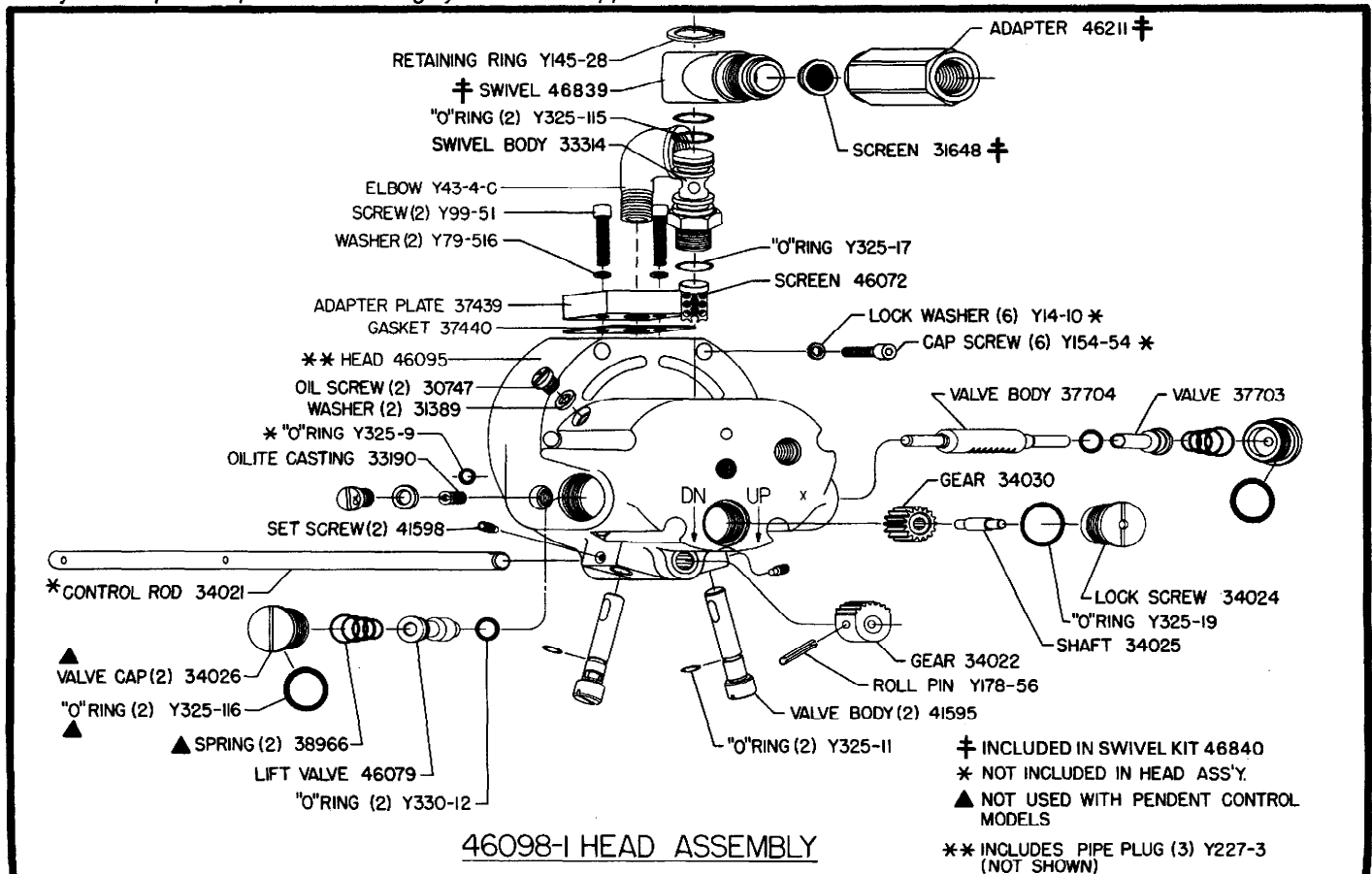

## ACCESSORIES SECTION

MODEL NO.	CAP. (LBS.)	TYPE BEAM	BEAM SIZE	FLANGE WIDTH	MINIMUM TURNING RADIUS
7702	1/2-TON	I-BEAM	4" TO 10"	2.660" TO 4.660"	24 INCHES
7761-BC*		I-BEAM	4" TO 10"	2.660" TO 4.660"	
7702-FT**		H-BEAM	4" TO 10"	2.660" TO 4.990"	
7727	1-TON	I-BEAM	5" TO 12"	3.000" TO 5.250"	36 INCHES
7762-BC*		I-BEAM	5" TO 12"	3.000" TO 5.250"	
7727-FT**		H-BEAM	5" TO 12"	2.600" TO 4.900"	

- \* SPARK-RESISTANT MODEL, EQUIPPED WITH BERYLLIUM COPPER TREAD WHEELS.
- \*\* FLAT TREAD WHEEL MODEL FOR USE WITH "H" TYPE BEAMS.
- \*\*\* SIDE PLATES ON SPARK-RESISTANT MODELS ARE EQUIPPED WITH SKID BRACKETS (44618-2) AND MOUNTED TO PLATES WITH RIVETS (Y193-33), NOT SHOWN.

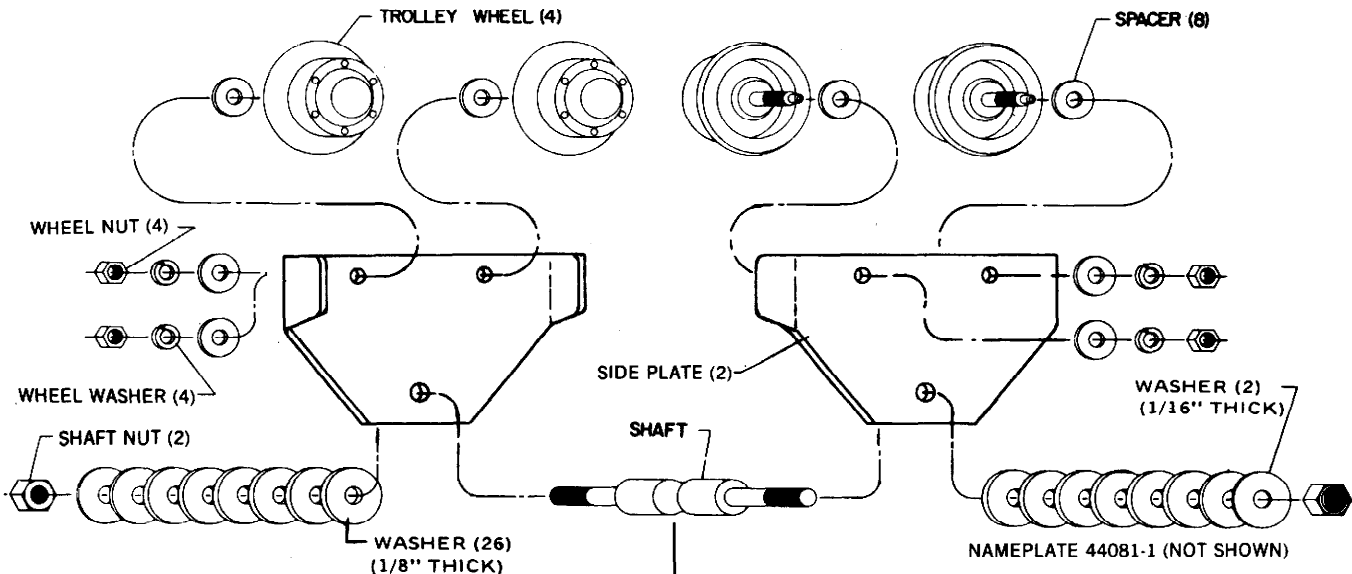

MODEL NO.	TROLLEY WHEEL	SIDE PLATE	SPACER (8)	WHEEL NUT	WHEEL WASHER	SHAFT	1/16" SHAFT WASHER	1/8" SHAFT WASHER	SHAFT NUT
7702	41008	41009	Y13-8	Y12-108	Y14-816	41010	41012	41013	41011
7761-BC	41008-1	41009-1	Y13-8	Y12-108	Y14-816	41010	41012	41013	41011
7702-FT	45375	41009	Y13-8	Y12-108	Y14-816	41010	41012	41013	41011
7727	41015	41016	41022	Y12-112	Y14-750	41017	41021	41020	41018
7762-BC	41015-1	41016-1	41022	Y12-112	Y14-750	41017	41021	41020	41018
7727-FT	45376	41016	41022	Y12-112	Y14-750	41017	41021	41020	41018

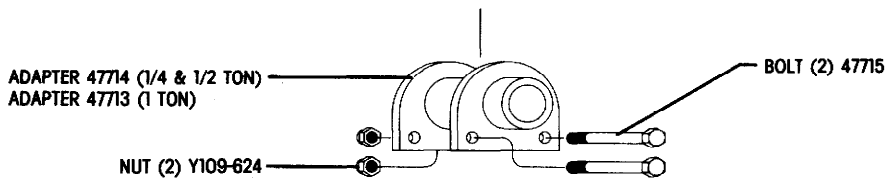

- 47717**      **1/4 AND 1/2-TON TROLLEY ADAPTER ASS'Y.**
- 47716**      **1-TON TROLLEY ADAPTER ASS'Y.**

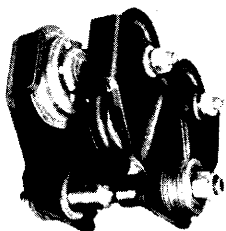

7702  
TROLLEY

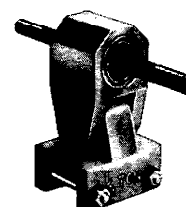

41938  
DUAL SWIVEL  
TROLLEY  
ADAPTER

No. 41938 Dual Swivel Trolley Adapter, for 1/4-ton and 1/2-ton hoists, may be used with Trolley No. 7702-( ) and 7761-( ).

**HOIST WILL NOT OPERATE — CHECK FOR:**

1. Excessive Load.
2. Sufficient air pressure.
3. Clogged air intake screen.
4. Clogged valves.
5. Proper brake adjustment.
6. Proper installation of Roll Pin in Control Rod and Gear (34022).

**UNABLE TO REGULATE HOIST SPEED BY CONTROLS  
CHECK FOR:**

1. Proper brake adjustment.

**HOIST WILL NOT HOLD LOAD IN SUSPENSION —  
CHECK FOR:**

1. Excessive load.
2. Worn or oily brake linings.
3. Proper brake adjustment.
4. Proper timing of gears in head.

**HOIST LOSES POWER — CHECK FOR:**

1. Sufficient air pressure.
2. Clogged air intake screen.
3. Clogged muffler screen or filler.

**HOIST LIFTING OR LOWERING SPEED DIFFERS FROM RATED  
SPEED AT FULL LOAD — CHECK FOR:**

1. Proper timing of gears in Head.

**HOIST CONTROL LEVER WILL NOT RETURN TO  
HORIZONTAL POSITION — CHECK FOR:**

1. Bent control rod.
2. Binding of control rod.
3. Proper brake adjustment.
4. Lack of lubrication in pendent control cylinders.
5. Proper timing of gears in head.

**SERVICE KITS**

**SERVICE KIT NO. 41329-1  
(FOR LINK CHAIN HOISTS)**

CONSISTING OF:

QTY	PART NO.	DESCRIPTION	QTY	PART NO.	DESCRIPTION
1	33274	Lockwasher	1	Y145-28	Retainer Ring
1	33387-2	Brake Shoe Kit	2	Y325-11	"O" Ring
3	34028	Filler	2	Y325-12	"O" Ring
1	35023	Safety Latch	1	Y325-17	"O" Ring
1	41623	Gasket	1	Y325-19	"O" Ring
1	41795	Motor Oil	2	Y325-115	"O" Ring
2	41799	Gear Lube	2	Y325-116	"O" Ring
8	43067	Blade	1	Y325-154	"O" Ring
1	Y1-966	Washer	2	Y330-12	"O" Ring

DOES NOT INCLUDE CHAIN, POCKET WHEEL OR SPROCKET

**SERVICE KIT NO. 41329-2  
(FOR ROLLER CHAIN HOISTS)**

CONSISTING OF:

QTY	PART NO.	DESCRIPTION	QTY	PART NO.	DESCRIPTION
1	33274	Lockwasher	1	Y145-28	Retainer Ring
2	33387	Brake Shoe	2	Y325-11	"O" Ring
3	34028	Filler	2	Y325-12	"O" Ring
1	35023	Safety Latch	1	Y325-17	"O" Ring
1	41623	Gasket	1	Y325-19	"O" Ring
1	41795	Motor Oil	2	Y325-115	"O" Ring
2	41799	Gear Lube	2	Y325-116	"O" Ring
8	43067	Blade	1	Y325-154	"O" Ring
1	Y1-966	Washer	2	Y330-12	"O" Ring

DOES NOT INCLUDE CHAIN, POCKET WHEEL OR SPROCKET

**SERVICE KIT NO. 41335**

CONSISTING OF:

QTY.	PART NO.	DESCRIPTION
1	33375	Sprocket Wheel
1	34991	Chain Guide
4	33330	Fasteners

**SERVICE KIT NO. 41336**

CONSISTING OF:

QTY.	PART NO.	DESCRIPTION
1	37571	Pocket Wheel
1	35861	Chain Guide
4	33330	Fasteners

## BULLARD SNAP HOOKS

- 35205-1 Lower Hook Assembly for 1/4 and 1/2 Ton ROLLER CHAIN only. Includes Bucket Swivel, Steel Balls, Collar, Roll Pins, Connector and Pin.
- 35206 Lower Hook Assembly for 1/4 and 1/2 Ton LINK CHAIN only. Includes Bucket Swivel, Steel Balls, Collar, Roll Pins, Connector, Pin, Sleeve and Snap Ring.
- 35203 Upper Hook Assembly for 1/4, 1/2 and 1-Ton Link and Roller Chain. Includes Mounting Bracket, Bearing, Sleeve and Roll Pin.
- 45934 Lower Hook and Block Assembly for 1-Ton LINK CHAIN only. Includes Sheave Assembly, Shroud's and all necessary components for attaching to load chain.
- 45935 Lower Hook and Block Assembly for 1-Ton ROLLER CHAIN only. Includes Sprocket Assembly, Shroud's and all necessary components for attaching to load chain.
- 45374 Lower Hook (with latch) Only for 1-Ton LINK and ROLLER CHAIN. (Same hook as furnished with 45934 and 45935 assemblies).

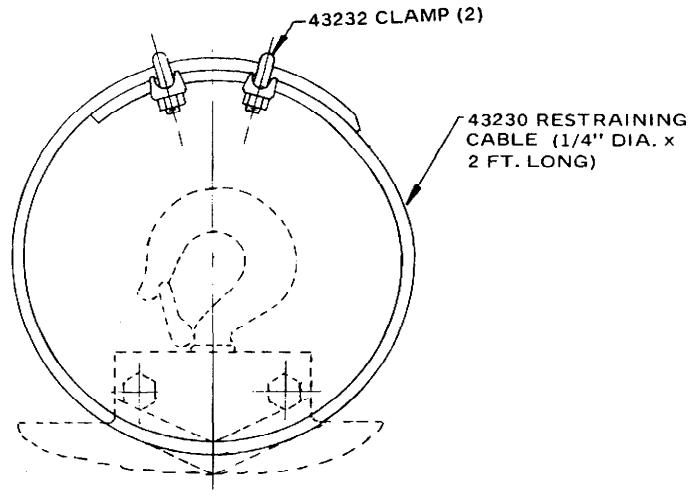

**43231 RESTRAINING CABLE ASS'Y.**

FOR USE AS AN ADDED SAFETY PRECAUTION IN HOIST SUSPENSION. INSERT CABLE THRU HOLE PROVIDED IN HOUSING AS SHOWN AND AROUND I-BEAM (OR OTHER OVERHEAD SUPPORT CAPABLE OF SAFELY SUPPORTING COMBINED WEIGHT OF HOIST AND ITS CAPACITY LOAD).

## Hose-Carrier Trolleys



MODEL  
7703

Recommended when hoist is trolley-mounted. Adjustable clamp fits hose in sizes up to 1-1/4" o.d. can be mounted on the same beam that carries the hoist trolley. Use on I-beams from 3" to 10" high, having minimum width of 2-3/8" and maximum width of 5-3/32". For best results, use one trolley at each 8' hose interval.

## Brake Spring Spreader

No. 33541

Specifically designed for hoist brake spring. Develops strong leverage for spreading brake band open when removal is required for service or maintenance.





**SERIES 7700 HOIST CHAIN BASKET INSTALLATION**

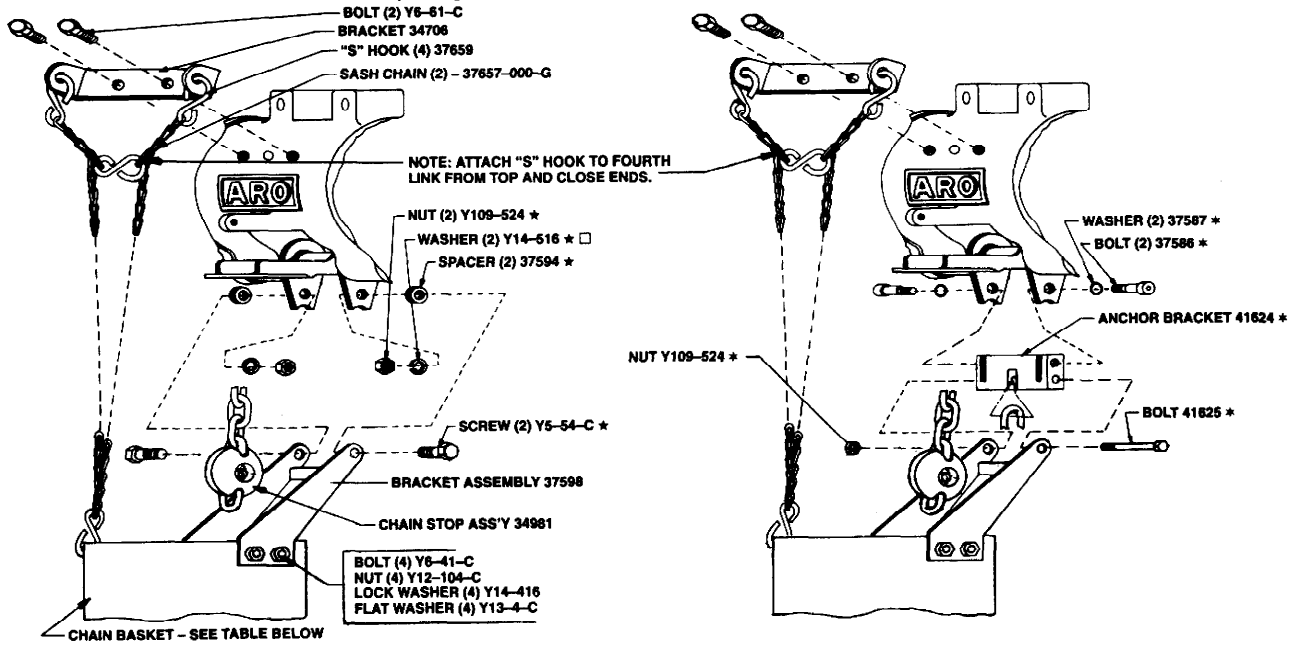

**1/4 & 1/2 TON LINK CHAIN MODELS**

**1-TON LINK CHAIN MODELS**

□ NOT INCLUDED WITH MODELS 43554-{}.

NOTE: WHEN MOUNTING BASKET TO HOIST, REMOVE CHAIN END ATTACHMENT FROM HOIST AND ASSEMBLE CHAIN STOP (34981) WITH BOLT THRU SECOND LINK FROM END.

CHAIN BASKET ASSEMBLY NUMBER	CHAIN CAPACITY	CHAIN BASKET NUMBER	BASKET MATERIAL
37653-16	20'	36384-1	STEEL
37653-32	32'	36384-2	STEEL
37653-64	56'	36384-3	STEEL
37653-80	80'	36384-7	STEEL
37653-100	100'	36384-10	STEEL
43554-1	20'	43440-1	CANVAS
43554-2	32'	43440-2	CANVAS
43554-3	64'	43440-3	CANVAS

NOTE: ON 1-TON MODELS, BASKET IS ATTACHED TO ANCHOR BRACKET. PARTS MARKED \* ARE NOT USED.

\* STANDARD 1-TON HOIST PARTS.

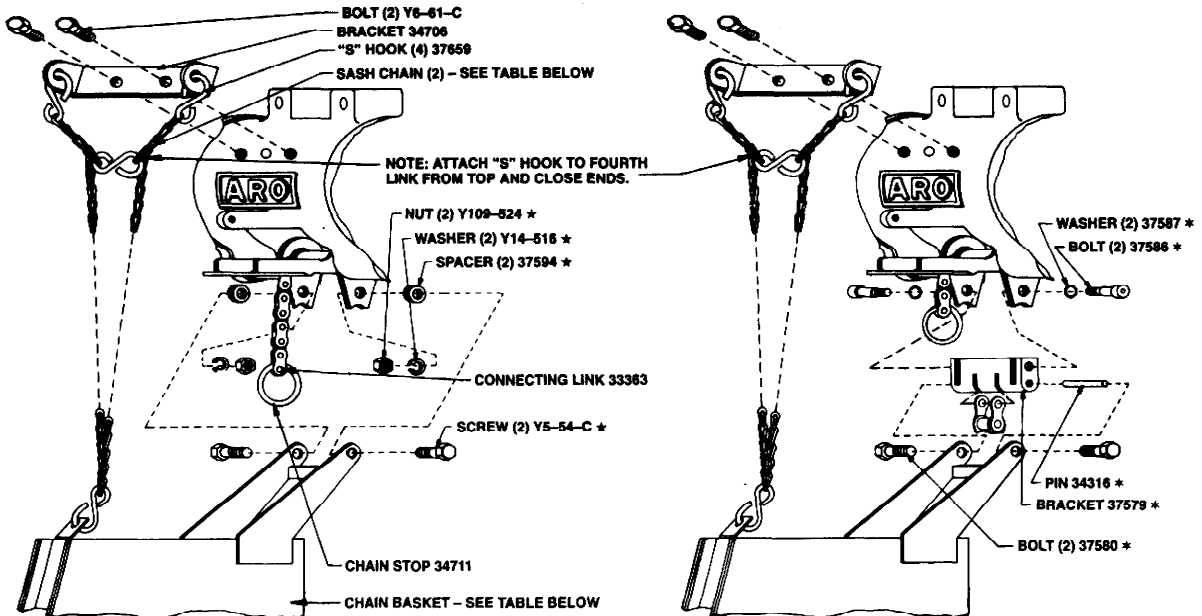

**1/4 & 1/2 TON ROLLER CHAIN MODELS**

**1-TON ROLLER CHAIN MODELS**

CHAIN BASKET ASSEMBLY NUMBER	CHAIN CAPACITY	CHAIN BASKET NUMBER	SASH CHAIN
37654	10'	37660	37657-000-F
37655	16'	37661	37657-000-G
37656	40'	37658	37657-000-J

NOTE: ON 1-TON MODELS, BASKET IS ATTACHED TO ANCHOR BRACKET. PARTS MARKED \* ARE NOT USED.

\* STANDARD 1-TON HOIST PARTS.

NOTE: CHAIN STOP (RING) 34711 IS ASSEMBLED TO END OF LOAD CHAIN AND CHAIN STOP ASSEMBLY 33382 (USED WITH 1/4 AND 1/2 TON MODELS) IS REMOVED. CHAIN STOP 33382 IS TOO WIDE TO FIT CHAIN BASKET.







---

Part of worldwide Ingersoll-Rand

PN 49999-016