

## OPERATION AND MAINTENANCE MANUAL FOR SERIES QA ANGLE DRILLS

### NOTICE

Series QA Angle Drills are designed for drilling operations in the aerospace, automotive, appliance, electronic, machining and furniture industries. Ingersoll-Rand is not responsible for customer modification of tools for applications on which Ingersoll-Rand was not consulted.

### ⚠ WARNING

**IMPORTANT SAFETY INFORMATION ENCLOSED.  
READ THIS MANUAL BEFORE OPERATING TOOL.**

**IT IS THE RESPONSIBILITY OF THE EMPLOYER TO PLACE THE INFORMATION  
IN THIS MANUAL INTO THE HANDS OF THE OPERATOR.  
FAILURE TO OBSERVE THE FOLLOWING WARNINGS COULD RESULT IN INJURY.**

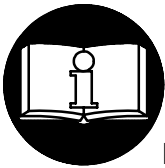

#### PLACING TOOL IN SERVICE

- Always operate, inspect and maintain this tool in accordance with American National Standards Institute Safety Code for Portable Air Tools (ANSI B186.1).
- For safety, top performance, and maximum durability of parts, operate this tool at 90 psig (6.2 bar/620 kPa) maximum air pressure at the inlet with 1/4" (6 mm) inside diameter air supply hose.
- Always turn off the air supply and disconnect the air supply hose before installing, removing or adjusting any accessory on this tool, or before performing any maintenance on this tool.
- Do not use damaged, frayed or deteriorated air hoses and fittings.
- Be sure all hoses and fittings are the correct size and are tightly secured. See Dwg. TPD905-1 for a typical piping arrangement.
- Always use clean, dry air at 90 psig (6.2 bar/620 kPa) maximum air pressure. Dust, corrosive fumes and/or excessive moisture can ruin the motor of an air tool.
- Do not lubricate tools with flammable or volatile liquids such as kerosene, diesel or jet fuel.
- Do not remove any labels. Replace any damaged label.

#### USING THE TOOL

- Always wear eye protection when operating or performing maintenance on this tool.
- Always wear hearing protection when operating this tool.
- Keep hands, loose clothing and long hair away from rotating end of tool.
- Note the position of the reversing lever before operating the tool so as to be aware of the direction of rotation when operating the throttle.
- Anticipate and be alert for sudden changes in motion during start up and operation of any power tool.
- Keep body stance balanced and firm. Do not overreach when operating this tool. High reaction torques can occur at or below the recommended air pressure.
- Tool accessory may continue to rotate briefly after throttle is released.
- Air powered tools can vibrate in use. Vibration, repetitive motions or uncomfortable positions may be harmful to your hands and arms. Stop using any tool if discomfort, tingling feeling or pain occurs. Seek medical advice before resuming use.
- Use accessories recommended by Ingersoll-Rand.
- This tool is not insulated against electric shock.
- This tool is not designed for working in explosive atmospheres.

### NOTICE

The use of other than genuine Ingersoll-Rand replacement parts may result in safety hazards, decreased tool performance, and increased maintenance, and may invalidate all warranties.

Repairs should be made only by authorized trained personnel. Consult your nearest Ingersoll-Rand Authorized Servicenter.

Refer All Communications to the Nearest  
Ingersoll-Rand Office or Distributor.

© Ingersoll-Rand Company 2000

Printed in U.S.A.



# WARNING LABEL IDENTIFICATION



FAILURE TO OBSERVE THE FOLLOWING WARNINGS COULD RESULT IN INJURY.

	<p><b>WARNING</b></p> <p>Always wear eye protection when operating or performing maintenance on this tool.</p>
--	--

	<p><b>WARNING</b></p> <p>Always wear hearing protection when operating this tool.</p>
--	---

	<p><b>WARNING</b></p> <p>Always turn off the air supply and disconnect the air supply hose before installing, removing or adjusting any accessory on this tool, or before performing any maintenance on this tool.</p>
--	--

	<p><b>WARNING</b></p> <p>Air powered tools can vibrate in use. Vibration, repetitive motions or uncomfortable positions may be harmful to your hands and arms. Stop using any tool if discomfort, tingling feeling or pain occurs. Seek medical advice before resuming use.</p>
--	---

	<p><b>WARNING</b></p> <p>Do not carry the tool by the hose.</p>
--	---

	<p><b>WARNING</b></p> <p>Do not use damaged, frayed or deteriorated air hoses and fittings.</p>
--	---

	<p><b>WARNING</b></p> <p>Keep body stance balanced and firm. Do not overreach when operating this tool.</p>
--	---

	<p><b>WARNING</b></p> <p>Operate at 90 psig (6.2 bar/620 kPa) Maximum air pressure.</p>
--	---

## PLACING TOOL IN SERVICE

### LUBRICATION



Ingersoll-Rand No. 10 Gearing:  
Ingersoll-Rand No. 67 Grease

Always use an air line lubricator with this tool.  
We recommend the following Filter-Lubricator-Regulator Unit:

For USA – No. C08-02-FKG0-28

Whenever the tool is disassembled for maintenance or repair, lubricate the gear train with Ingersoll-Rand No. 67 Grease.

After every 40,000 cycles or one month, or as experience indicates, inject 2 to 4 cc of Ingersoll-Rand No. 67 Grease into the Grease Fitting on the Angle Attachment.

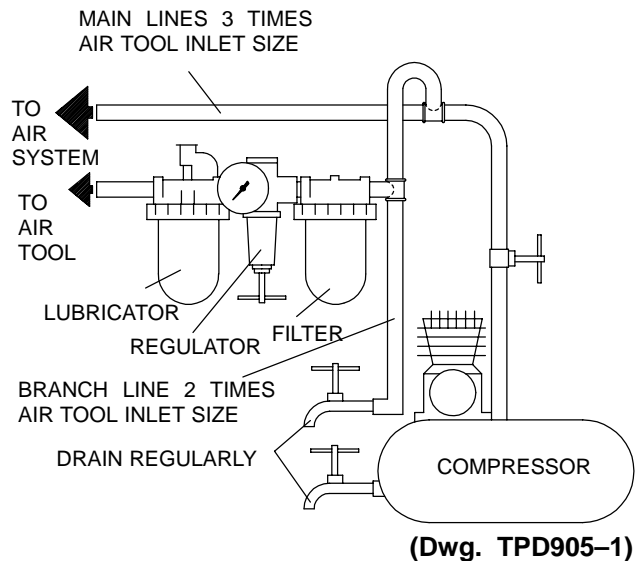

## MODEL IDENTIFICATION

### Tool Style

QA (Angle)

### Free Speed

**35** (3500)  
**27** (2700)  
**21** (2100)  
**17** (1750)  
**12** (1270)  
**08** (0850)  
**05** (0500)

### Spindle

**1** (1/4" Chuck; large head)  
**3** (3/16" Collet; small head)  
**5** (1/4"-28 Female thread;  
small head)

### Angle Head

**9** (90°)  
**4** (45°)

### Accessory

**D** (Memory Chip)  
**B** (1/4-19 BSPT  
Inlet)

**QA**

**12**

**1**

**9**

**D**

# MANUEL D'EXPLOITATION ET D'ENTRETIEN DES TOURNEVIS ET DES PERCEUSES D'ANGLE DE LA SERIE QA

## NOTE

Les perceuses d'angle de la Série QA sont destinées aux opérations de perçage dans les industries de l'aérospatiale, de l'automobile, des appareils ménagers, de l'électronique, de l'usinage et des meubles.

Ingersoll–Rand ne peut être tenu responsable de la modification des outils par le client pour les adapter à des applications qui n'ont pas été approuvées par Ingersoll–Rand.

## ⚠ ATTENTION

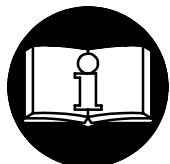

**D'IMPORTANTES INFORMATIONS DE SECURITÉ SONT JOINTES.  
LIRE CE MANUEL AVANT D'UTILISER L'OUTIL.  
L'EMPLOYEUR EST TENU À COMMUNIQUER LES INFORMATIONS  
DE CE MANUEL AUX EMPLOYÉS UTILISANT CET OUTIL.**

**LE NON RESPECT DES AVERTISSEMENTS SUIVANTS PEUT CAUSER DES BLESSURES**

### MISE EN SERVICE DE L'OUTIL

- Toujours exploiter, inspecter et entretenir cet outil conformément au Code de sécurité des outils pneumatiques portatifs de l'American National Standards Institute (ANSI B186.1).
- Pour la sécurité, les performances optimales et la durabilité maximale des pièces, cet outil doit être connecté à une alimentation d'air comprimé de 6,2 bar (620 kPa) maximum à l'entrée, avec un flexible de 6 mm de diamètre intérieur.
- Couper toujours l'alimentation d'air comprimé et débrancher le flexible d'alimentation avant d'installer, déposer ou ajuster tout accessoire sur cet outil, ou d'entreprendre une opération d'entretien quelconque sur l'outil.
- Ne pas utiliser des flexibles ou des raccords endommagés, effilochés ou détériorés.
- S'assurer que tous les flexibles et les raccords sont correctement dimensionnés et bien serrés. Voir Plan TPD905–1 pour un exemple type d'agencement des tuyauteries.
- Utiliser toujours de l'air sec et propre à une pression maximum de 6,2 bar (620 kPa). La poussière, les fumées corrosives et/ou une humidité excessive peuvent endommager le moteur d'un outil pneumatique.
- Ne jamais lubrifier les outils avec des liquides inflammables ou volatils tels que le kérosène, le gasol ou le carburant d'aviation.
- Ne retirer aucune étiquette. Remplacer toute étiquette endommagée.

### UTILISATION DE L'OUTIL

- Porter toujours des lunettes de protection pendant l'utilisation et l'entretien de cet outil.
- Porter toujours une protection acoustique pendant l'utilisation de cet outil.
- Tenir les mains, les vêtements flous et les cheveux longs, éloignés de l'extrémité rotative de l'outil.
- Noter la position du levier d'inversion avant de mettre l'outil en marche de manière à savoir dans quel sens il va tourner lorsque la commande est actionnée.
- Prévoir, et ne pas oublier, que tout outil motorisé est susceptible d'à-coups brusques lors de sa mise en marche et pendant son utilisation.
- Garder une position équilibrée et ferme. Ne pas se pencher trop en avant pendant l'utilisation de cet outil. Des couples de réaction élevés peuvent se produire à, ou en dessous, de la pression d'air recommandée.
- La percussion des accessoires de l'outil peut continuer pendant un certain temps après le relâchement de la gâchette.
- Les outils pneumatiques peuvent vibrer pendant l'exploitation. Les vibrations, les mouvements répétitifs et les positions inconfortables peuvent causer des douleurs dans les mains et les bras. N'utiliser plus d'outils en cas d'inconfort, de picotements ou de douleurs. Consulter un médecin avant de recommencer à utiliser l'outil.
- Utiliser les accessoires recommandés par Ingersoll–Rand.
- Cet outil n'est pas conçu pour fonctionner dans des atmosphères explosives.
- Cet outil n'est pas isolé contre les chocs électriques.

## NOTE

L'utilisation de rechanges autres que les pièces d'origine Ingersoll–Rand peut causer des risques d'insécurité, réduire les performances de l'outil et augmenter l'entretien, et peut annuler toutes les garanties.

Les réparations ne doivent être effectuées que par des réparateurs qualifiés autorisés. Consultez votre Centre de Service Ingersoll–Rand le plus proche.

Adressez toutes vos communications au Bureau Ingersoll–Rand ou distributeur le plus proche.

© Ingersoll–Rand Company 2000

Imprimé aux É.U.



# SIGNIFICATION DES ETIQUETTES D'AVERTISSEMENT

## ATTENTION

LE NON RESPECT DES AVERTISSEMENTS SUIVANTS PEUT CAUSER DES BLESSURES

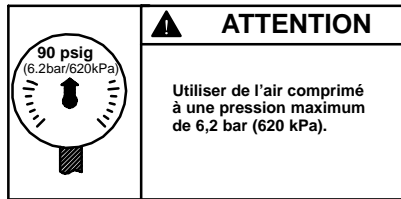
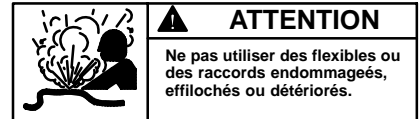
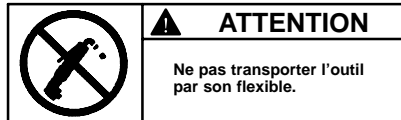
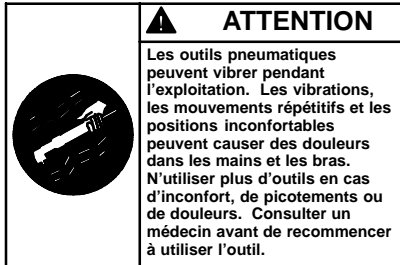
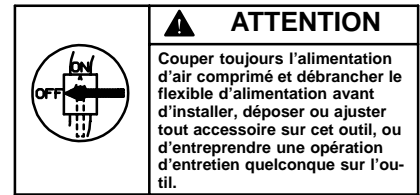
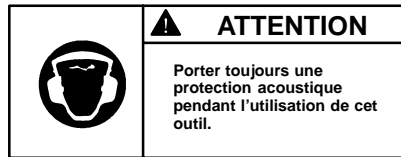
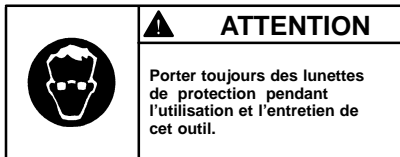

## MISE EN SERVICE DE L'OUTIL

### LUBRIFICATION



Ingersoll-Rand No. 10 Pignonnerie:  
Ingersoll-Rand No. 67

Utiliser toujours un lubrificateur avec ces outils. Nous recommandons l'emploi du filtre-régulateur-lubrificateur suivant:

É.U. - No. C08-02-FKG0-28

Lubrifier le train d'engrenages avec de la graisse Ingersoll-Rand No. 67 à chaque fois que l'outil est démonté pour entretien ou réparation.

Tous les 40.000 cycles ou au moins tous les mois, selon le cas, injecter 2 à 4 cm<sup>3</sup> de graisse Ingersoll-Rand No. 67 dans le raccord de graissage du renvoi d'angle.

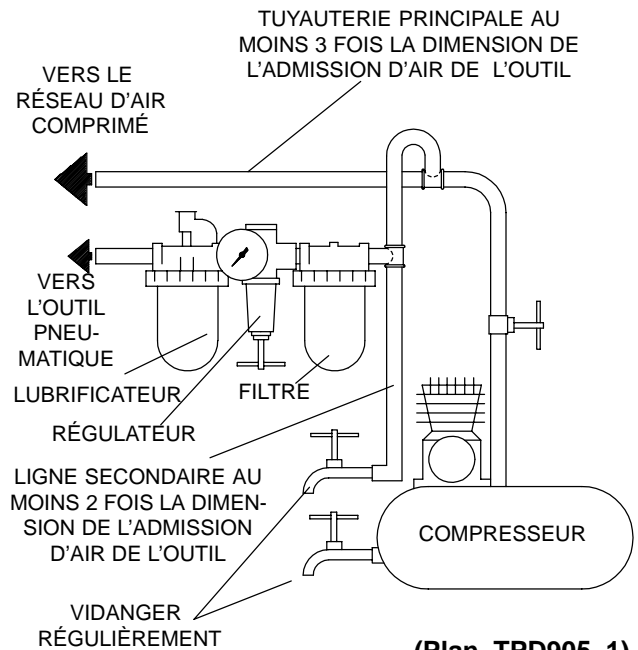

(Plan TPD905-1)

## IDENTIFICATION DES MODÈLES

**Style d'outil**

**Vitesse à vide**

**Type de sortie**

**Renvoi d'angle**

**Accessoire**

**QA** (Angle)

**35** (3500)

**27** (2700)

**21** (2100)

**17** (1750)

**12** (1270)

**08** (0850)

**05** (0500)

**1** (Mandrin 1/4"; grosse tête)

**3** (Pince 3/16"; petite tête)

**5** (Filetage femelle 1/4"-28;  
petite tête)

**9** (90°)

**4** (45°)

**D** (Puce mémoire)

**B** (1/4-19 BSPT  
Tuyau d'entrée)

**QA**

**12**

**1**

**9**

**D**

# MANUAL DE USO Y MANTENIMIENTO PARA TALADROS ANGULARES DE LA SERIE QA

## NOTA

Los taladros angulares de la serie QA están diseñados para las operaciones de taladrado de las industrias aeroespacial, del automóvil, de electrodomésticos, electrónica, mecánica y del mueble.

Ingersoll–Rand no aceptará responsabilidad alguna por la modificación de las herramientas efectuada por el cliente para las aplicaciones que no hayan sido consultadas con Ingersoll–Rand.



## AVISO

SE ADJUNTA INFORMACION IMPORTANTE DE SEGURIDAD.  
LEA ESTE MANUAL ANTES DE USAR LA HERRAMIENTA.

ES RESPONSABILIDAD DE LA EMPRESA ASEGURARSE DE QUE EL OPERARIO  
ESTE AL TANTO DE LA INFORMACION QUE CONTIENE ESTE MANUAL.

EL HACER CASO OMISO DE LOS AVISOS SIGUIENTES PODRIA OCASIONAR LESIONES.

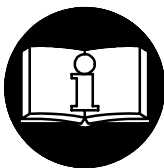

### PARA PONER LA HERRAMIENTA EN SERVICIO

- Utilice, examine y mantenga siempre esta herramienta conforme al código de seguridad para herramientas neumáticas portátiles de la American National Standards Institute (ANSI B186.1).
- Para seguridad, máximo rendimiento y durabilidad de piezas, use esta herramienta a una máxima presión de aire de 90 psig (6,2 bar/620kPa) en la admisión de manguera de suministro de aire de diámetro interno de 6 mm.
- Corte siempre el suministro de aire y desconecte la manguera de suministro de aire antes de instalar, desmontar o ajustar cualquier accesorio de esta herramienta, o antes de realizar cualquier operación de mantenimiento de la misma.
- No utilice mangueras de aire y accesorios dañados, desgastados ni deteriorados.
- Asegúrese de que todas las mangueras y los accesorios sean del tamaño correcto y estén bien apretados. Vea Esq. TPD905–1 para un típico arreglo de tuberías.
- Use siempre aire limpio y seco a una máxima presión de 90 psig (6,2 bar/620kPa). El polvo, los gases corrosivos y/o el exceso de humedad podrían estropear el motor de una herramienta neumática.
- No lubrique las herramientas con líquidos inflamables o volátiles tales como queroseno, gasoil o combustible para motores a reacción.
- No saque ninguna etiqueta. Sustituya toda etiqueta dañada.

### USO DE HERRAMIENTA

- Use siempre protección ocular cuando utilice esta herramienta o realice operaciones de mantenimiento en la misma.
- Use siempre protección para los oídos cuando utilice esta herramienta.
- Mantenga las manos, la ropa suelta y el cabello largo alejados del extremo giratorio de la herramienta.
- Note la posición de la palanca de inversión antes de funcionar la herramienta para estar consciente de su dirección giratoria cuando funcione el estrangulador.
- Anticipe y esté alerta a los cambios repentinos en el movimiento durante la puesta en marcha y el manejo de toda herramienta motorizada.
- Mantenga una postura de cuerpo equilibrada y firme. No estire demasiado los brazos al manejar la herramienta. Pueden ocurrir reacciones de alto par a, o menos de, la recomendada presión de aire.
- El accesorio de herramienta podría seguir girando brevemente después de haber soltado la palanca de estrangulación.
- Las herramientas neumáticas pueden vibrar durante el uso. La vibración, repetición o posiciones incómodas pueden dañarle los brazos y manos. En caso de incomodidad, sensación de hormigueo o dolor, deje de usar la herramienta. Consulte a un médico antes de volver a usarla otra vez.
- Utilice únicamente los accesorios Ingersoll–Rand recomendados.
- Esta herramienta no ha sido diseñada para trabajar en ambientes explosivos.
- Esta herramienta no está aislada contra descargas eléctricas.

## NOTA

El uso de piezas de recambio que no sean las auténticas piezas Ingersoll–Rand podría poner en peligro la seguridad, reducir el rendimiento de la herramienta y aumentar los cuidados de mantenimiento necesarios, así como invalidar toda garantía.

Las reparaciones sólo serán realizadas por personal cualificado y autorizado. Consulte con el centro de servicio Ingersoll–Rand autorizado más próximo.

Toda comunicación se deberá dirigir a la oficina o al distribuidor Ingersoll–Rand más próximo.

© Ingersoll–Rand Company 2000

Impreso en EE. UU.



## ETIQUETAS DE AVISO

### ⚠ AVISO

EL HACER CASO OMISO DE LOS AVISOS SIGUIENTES PODRIA OCASIONAR LESIONES.

	<p><b>⚠ ADVERTENCIA</b></p> <p>Use siempre protección ocular cuando utilice esta herramienta o realice operaciones de mantenimiento en la misma.</p>
---	--

	<p><b>⚠ ADVERTENCIA</b></p> <p>Use siempre protección para los oídos cuando utilice esta herramienta.</p>
---	---

	<p><b>⚠ ADVERTENCIA</b></p> <p>Cortar siempre el suministro de aire y desconectar la manguera de suministro de aire antes de instalar, retirar o ajustar cualquier accesorio de esta herramienta, o antes de realizar cualquier operación de mantenimiento de la misma.</p>
---	---

	<p><b>⚠ ADVERTENCIA</b></p> <p>Las herramientas neumáticas pueden vibrar durante el uso. La vibración, los movimientos repetitivos o las posiciones incómodas podrían dañarle los brazos y las manos. En caso de incomodidad, sensación de hormigueo o dolor, dejar de usar la herramienta. Consultar al médico antes de volver a utilizarla.</p>
---	---

	<p><b>⚠ ADVERTENCIA</b></p> <p>No coger la herramienta por la manguera para levantarla.</p>
---	---

	<p><b>⚠ ADVERTENCIA</b></p> <p>No utilizar mangueras de aire y accesorios dañados, desgastados ni deteriorados.</p>
---	---

	<p><b>⚠ ADVERTENCIA</b></p> <p>Mantener una postura del cuerpo equilibrada y firme. No estirar demasiado los brazos al manejar la herramienta.</p>
---	--

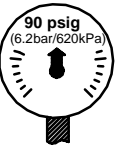
	<p><b>⚠ ADVERTENCIA</b></p> <p>Manejar la herramienta a una presión de aire máxima de 90 psig (6,2 bar/620 kPa).</p>
---	--

## PARA PONER LA HERRAMIENTA EN SERVICIO

### LUBRICACION



Ingersoll-Rand N° 10

Engranajes:

Ingersoll-Rand N° 67

Utilice siempre un lubricador de aire comprimido con estas llaves de impacto. Recomendamos la siguiente unidad de Filtro-Lubricador-Regulador:

EE.UU. – N° C08-02-FKG0-28

Cada vez que se desarme la herramienta para realizarle trabajos de mantenimiento o reparación, lubrique el tren de engranajes con grasa Ingersoll-Rand N° 67.

Después de cada 40,000 ciclos o un mes de uso, o según indique la experiencia, inyecte 2-4 cc de grasa Ingersoll-Rand N° 67 en el engrasador de la cabeza angular.

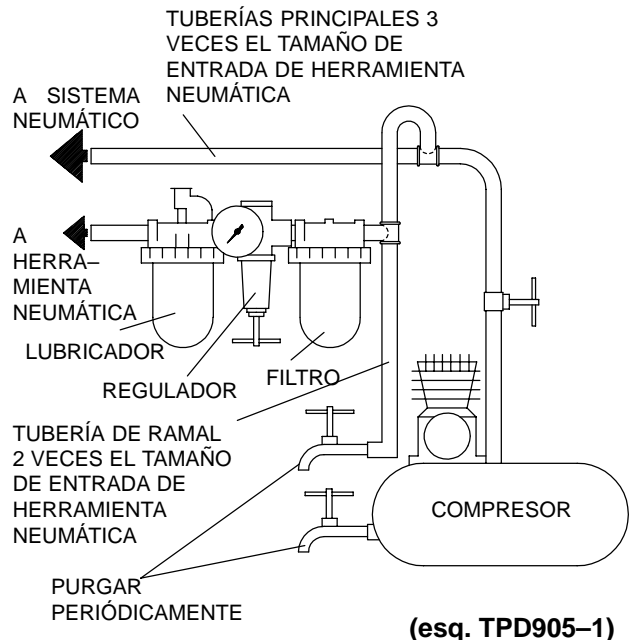

(esq. TPD905-1)



# IDENTIFICACIÓN DE MODELOS

**Estilo de herramienta**

**Velocidad**

**Ejo**

**Cabeza Angular**

**Accesorio**

**QA** (Angular)

**35** (3500)  
**27** (2700)  
**21** (2100)  
**17** (1750)  
**12** (1270)  
**08** (0850)  
**05** (0500)

**1** (portabrocas de 1/4",  
cabeza grande)  
**3** (pinza de 3/16",  
cabeza pequeña)  
**5** (1/4"-28 rosca hembra,  
cabeza pequeña)

**9** (90°)  
**4** (45°)

**D** (Chip de memoria)  
**B** (1/4-19 BSPT)

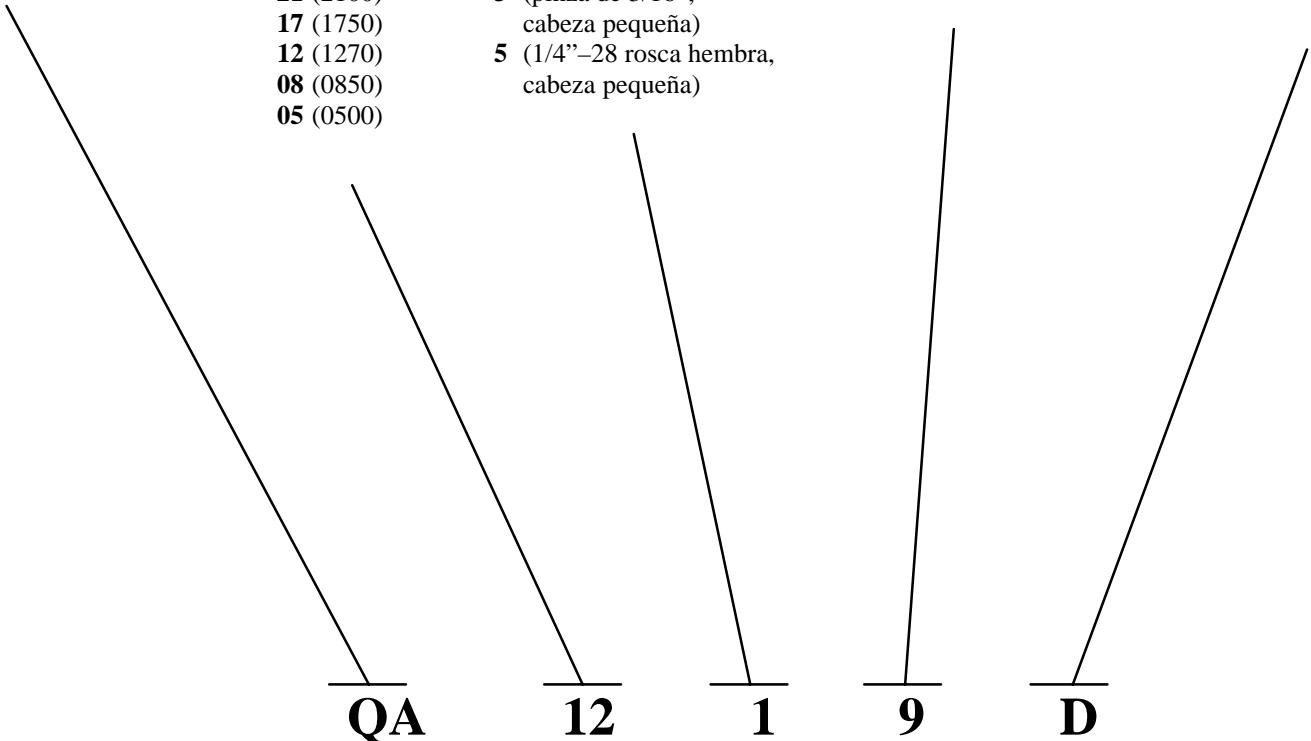

**QA**

**12**

**1**

**9**

**D**

# MANUAL DE FUNCIONAMENTO E MANUTENÇÃO PARA BERBEQUINS EM ÂNGULO SÉRIE QA

## AVISO

Os Berbequins em Ângulo Série QA são concebidos para operações de perfuração nas indústrias aeroespacial, automóvel, de aparelhos, electrónica, de maquinaria e de mobiliário. A Ingersoll–Rand não é responsável por modificações, feitas pelo cliente em ferramentas, nas quais a Ingersoll–Rand não tenha sido consultada.

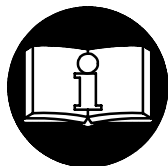

## ⚠️ ADVERTÊNCIA

**INFORMAÇÃO DE SEGURANÇA IMPORTANTE EM ANEXO  
LEIA ESTE MANUAL ANTES DE OPERAR A FERRAMENTA.  
É DA RESPONSABILIDADE DO EMPREGADOR COLOCAR  
A INFORMAÇÃO DESTES MANUAIS NAS MÃOS DO OPERADOR.**

**O NÃO CUMPRIMENTO DAS SEGUINTE ADVERTÊNCIAS PODE RESULTAR EM FERIMENTOS.**

### COLOCANDO A FERRAMENTA EM FUNCIONAMENTO

- Sempre opere, inspeccione e mantenha esta ferramenta de acordo com o Código de Segurança do Instituto Americano de Padrões Nacionais para Ferramentas Pneumáticas Portáteis (ANSI B186.1).
- Para segurança, máximo desempenho e máxima durabilidade das peças, opere esta ferramenta com uma pressão de ar máxima de 6,2 bar/620 kPa (90 psig) na entrada da mangueira de alimentação de ar com diâmetro interno de 6 mm (1/4”).
- Desligue sempre a alimentação de ar e desconecte a mangueira de alimentação de ar antes de instalar, remover ou ajustar qualquer acessório nesta ferramenta, ou antes de executar qualquer serviço de manutenção nesta ferramenta.
- Não use mangueiras de ar ou adaptadores danificados, gastos ou deteriorados.
- Certifique-se de que todas as mangueiras e adaptadores sejam do tamanho correcto e estejam apertados com firmeza. Veja o Desenho TPD905–1 para um arranjo típico de tubagem.
- Use sempre ar seco e limpo com pressão máxima de 6,2 bar/620 kPa (90 psig). Pó, fumos corrosivos e/ou humidade excessiva podem arruinar o motor de uma ferramenta pneumática.
- Não lubrifique as ferramentas com líquidos inflamáveis ou voláteis tais como querosene, diesel ou combustível de jactos.
- Não remova nenhum rótulo. Reponha qualquer rótulo danificado.

### USANDO A FERRAMENTA

- Use sempre óculos de protecção quando estiver operando ou executando serviço de manutenção nesta ferramenta.

- Use sempre protecção contra ruído ao operar esta ferramenta.
- Mantenha as mãos, partes do vestuário soltas e cabelos compridos afastados da extremidade em rotação.
- Observe qual é a posição da alavanca que reverte o sentido de rotação antes de operar esta ferramenta de modo a estar atento ao sentido de rotação quando operar o regulador de pressão.
- Antecipe e esteja alerta a mudanças repentinas no movimento quando ligar e operar qualquer ferramenta motorizada.
- Mantenha a posição do corpo equilibrada e firme. Não exagere quando operar esta ferramenta. Torques de reacção elevados podem ocorrer na ou abaixo da pressão de ar recomendada.
- Os acessórios da ferramenta podem continuar a girar brevemente após a pressão ter sido aliviada.
- Ferramentas accionadas pneumáticamente podem vibrar em uso. Vibração, movimentos repetitivos ou posições desconfortáveis podem ser prejudiciais às mãos e aos braços. Pare de usar a ferramenta caso ocorra algum desconforto, sensação de formigueiro ou dor. Procure assistência médica antes de retornar ao trabalho.
- Use acessórios recomendados pela Ingersoll–Rand.
- Esta Ferramenta não foi concebida para trabalhos em atmosferas explosivas.
- Esta Ferramenta não está isolada contra choques eléctricos.

## AVISO

O uso de peças de substituição que não sejam genuinamente da Ingersoll–Rand podem resultar em riscos de segurança, diminuição do desempenho da ferramenta, aumento da necessidade de manutenção e pode invalidar todas as garantias.

As reparações devem ser feitas somente por pessoal treinado autorizado. Consulte o Centro de Serviços da Ingersoll–Rand mais próximo.

Envie Todos os Comunicados Para o Distribuidor ou Escritório da Ingersoll–Rand Mais Próximo.

© Ingersoll–Rand Company 2000

Impresso nos E.U.A.



# IDENTIFICAÇÃO DO RÓTULO DE ADVERTÊNCIA

## ⚠️ ADVERTÊNCIA

O NÃO CUMPRIMENTO DAS SEGUINTE ADVERTÊNCIAS PODE RESULTAR EM FERIMENTO.



**⚠️ ADVERTÊNCIA**  
Use sempre óculos de protecção quando estiver operando ou executando algum serviço de manutenção nesta ferramenta.



**⚠️ ADVERTÊNCIA**  
Use sempre protecção contra o ruído ao operar esta ferramenta.



**⚠️ ADVERTÊNCIA**  
Desligue sempre a alimentação de ar e desconecte a mangueira de alimentação de ar antes de instalar, remover ou ajustar qualquer acessório nesta ferramenta, ou antes de executar algum serviço de manutenção nesta ferramenta.



**⚠️ ADVERTÊNCIA**  
Ferramentas accionadas pneumáticamente podem vibrar em uso. Vibração, movimentos repetitivos ou posições desconfortáveis podem ser prejudiciais às mãos e aos braços. Pare de usar a ferramenta caso ocorra algum desconforto, sensação de formigamento ou dor. Procure assistência médica antes de retornar ao trabalho.



**⚠️ ADVERTÊNCIA**  
Não carregue a ferramenta segurando na mangueira.



**⚠️ ADVERTÊNCIA**  
Não use mangueiras de ar ou adaptadores danificados, gastos ou deteriorados.



**⚠️ ADVERTÊNCIA**  
Mantenha a posição do corpo equilibrada e firme. Não exagere quando operar esta ferramenta. Torques de reacção elevados podem ocorrer sob a pressão de ar recomendada.

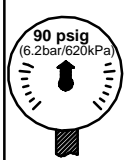

**⚠️ ADVERTÊNCIA**  
Opere com pressão do ar Máxima de 90-100 psig (6,2-6,9bar).

## COLOCANDO A FERRAMENTA EM FUNCIONAMENTO

### LUBRIFICAÇÃO



Ingersoll-Rand No. 10



Engrenagem:  
Ingersoll-Rand No. 67

Use sempre um lubrificador de ar de linha com estas ferramentas. Nós recomendamos a seguinte Unidade Filtro-Lubrificador-Regulador:

Para E.U.A. - No. C08-02-FKG0-28

Sempre que a ferramenta for desmontada para manutenção ou reparação, lubrifique o trem de engrenagens com Massa Ingersoll-Rand Nº 67.

Após cada 40 000 ciclos ou um mês, ou conforme a experiência indicar, injecte 2 a 4 cc de Massa Lubrificante Ingersoll-Rand Nº 67 no copo de lubrificação do acessório em ângulo.

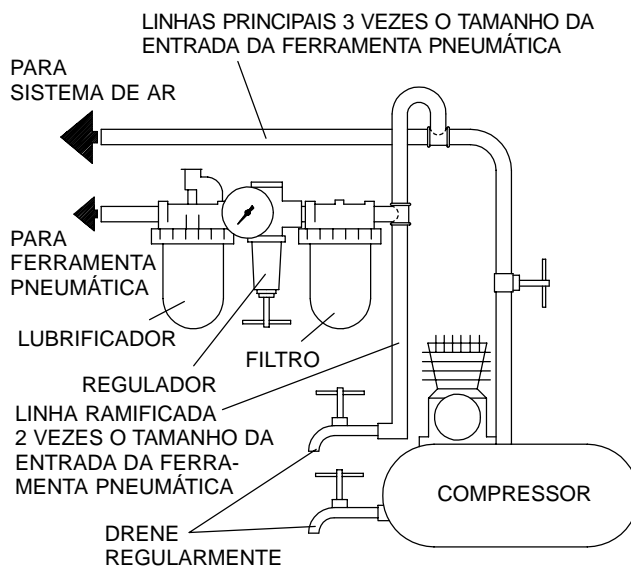

(Desenho TPD905-1)

## MODEL IDENTIFICATION

Estilo da ferramenta	Velocidade livre	Porta-brocas ou accionador	Cabeça em Ângulo	Acessório
<b>QA</b> (Ângulo)	<b>35</b> (3500)	<b>1</b> (Mandril de 1/4"; cabeça grande)	<b>9</b> (90°)	<b>D</b> (Chip de memória)
	<b>27</b> (2700)	<b>3</b> (Pinça de 3/16", cabeça pequena)	<b>4</b> (45°)	<b>B</b> (1/4-19 BSPT Entrada)
	<b>21</b> (2100)			
	<b>17</b> (1750)			
	<b>12</b> (1270)			
	<b>08</b> (0850)			
	<b>05</b> (0500)			

**QA**

**12**

**1**

**9**

**D**

# MOTOR AND GEARING FOR SERIES QA ANGLE DRILLS

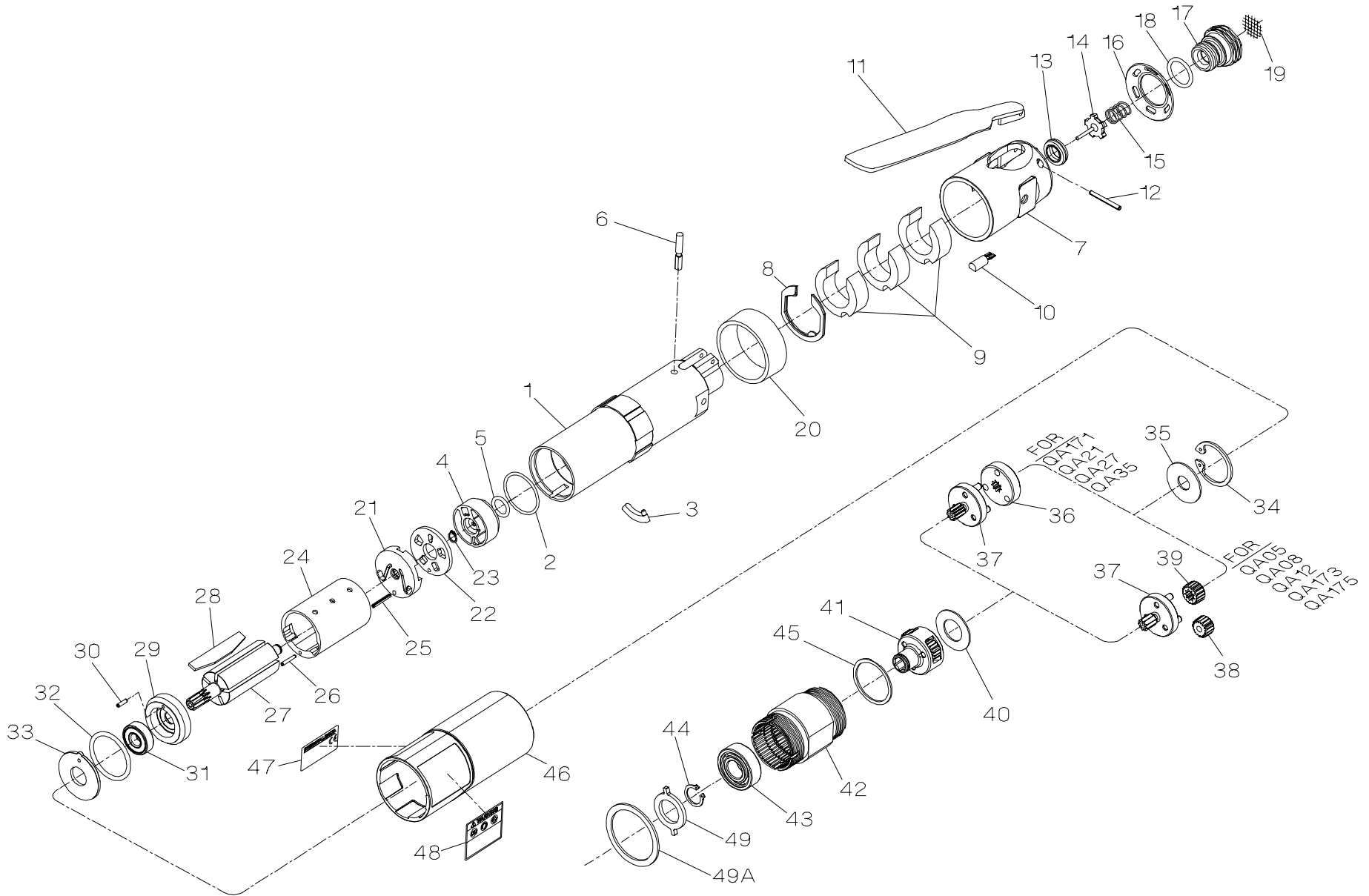



## MOTOR AND GEARING FOR SERIES QA ANGLE DRILLS

PART NUMBER FOR ORDERING

PART NUMBER FOR ORDERING

1	Motor Housing . . . . .	TRL-40	32	Motor Seal . . . . .	TRH-211
2	Housing O-ring . . . . .	TRH-104	33	Motor Clamp Washer . . . . .	TRH-207
3	Housing Plug . . . . .	TRD-982	34	Gear Retainer . . . . .	TRH-28
4	Reverse Valve Assembly . . . . .	TRH-A3291	35	Gear Head Spacer . . . . .	TRH-81
5	Reverse Valve Seal . . . . .	R1A-159	36	Planet Gear Head Drive Plate (for Series QA171 QA21, QA27 and QA35) . . . . .	TRH-17
6	Throttle Plunger . . . . .	TRL-302	37	Planet Gear Head Assembly (includes gear shafts)	
7	Back Cap . . . . .	TRL-231		for Series QA053, QA055, QA083, QA085, QA171, QA21, QA273, QA275 and QA351 . . . . .	TRH-A2169-16
8	Back Cap Gasket . . . . .	TRL-A283		for Series QA123 and QA125 . . . . .	TRH-A216-15
9	Muffler Element (3) . . . . .	TRL-311		for Series QA081 . . . . .	TRH-A21612-12
10	Memory Chip (only for models ending in D having a memory chip) . . . . .	TRH-800		for Series QA051, QA271, QA353 and QA355 . . . . .	TRH-A216-12
11	Throttle Lever . . . . .	TRL-273		for Series QA121, QA173 and QA175 ..	TRH-A2169-10
12	Throttle Lever Pin . . . . .	TRL-98	38	Planet Gear (3 for each Gear Head)	
13	Throttle Valve Seat . . . . .	TRH-303		for Series QA05, QA083 and QA085 ...	TRH-10-16
14	Throttle Valve . . . . .	TRD-A302		for Series QA081, QA123 and QA125 ..	TRH-10-12
15	Throttle Valve Spring . . . . .	TRL-51		for Series QA121, QA173 and QA175 ..	TRH-10-10
16	Exhaust Diffuser . . . . .	TRH-123	39	Gear Head Pinion	
17	Inlet Bushing Assembly . . . . .	TRH-A465		for Series QA121, QA173 and QA175 ..	TRH-17-21
18	Inlet Bushing Seal . . . . .	AF120-290		for Series QA081, QA123 and QA125 ..	TRH-17-18
19	Inlet Screen . . . . .	TRH-61	40	Planet Gear Head Spacer . . . . .	TRH-82
20	Housing Plug Cover . . . . .	TRD-981	41	Spindle Assembly (includes all spindle gearing)	
21	Rear End Plate Assembly (includes rear rotor bearing) . . . . .	TRH-A12-1		for Series QA053, QA055, QA171, QA21, QA273 and QA275 . . . . .	TRH-A8-16
22	Rear End Plate Face Plate . . . . .	TRH-12-2		for Series QA051, QA081, QA271, QA353 and QA355 . . . . .	TRH-A8-15
23	Rear End Plate Assembly Retainer . . . . .	8SL-305		for Series QA123 and QA125 . . . . .	TRH-A8-14
24	Cylinder Assembly . . . . .	TRH-A3-D		for Series QA083, QA085, QA121 and QA351 . . . . .	TRH-A8-12
25	Cylinder Rear Alignment Pin . . . . .	TRH-98		for Series QA173 and QA175 . . . . .	TRH-A8-10
26	Cylinder Front Alignment Pin . . . . .	TRH-98-1			
27	Rotor . . . . .	TRD-53			
28	Vane Packet (set of 5 Vanes) . . . . .	TRH-42-5			
29	Front End Plate Assembly . . . . .	TRH-A11			
30	End Plate Alignment Pin . . . . .	TRH-98-2			
31	Front Rotor Bearing . . . . .	TRH-24			

# ANGLE HEADS FOR SERIES QA ANGLE DRILLS

15

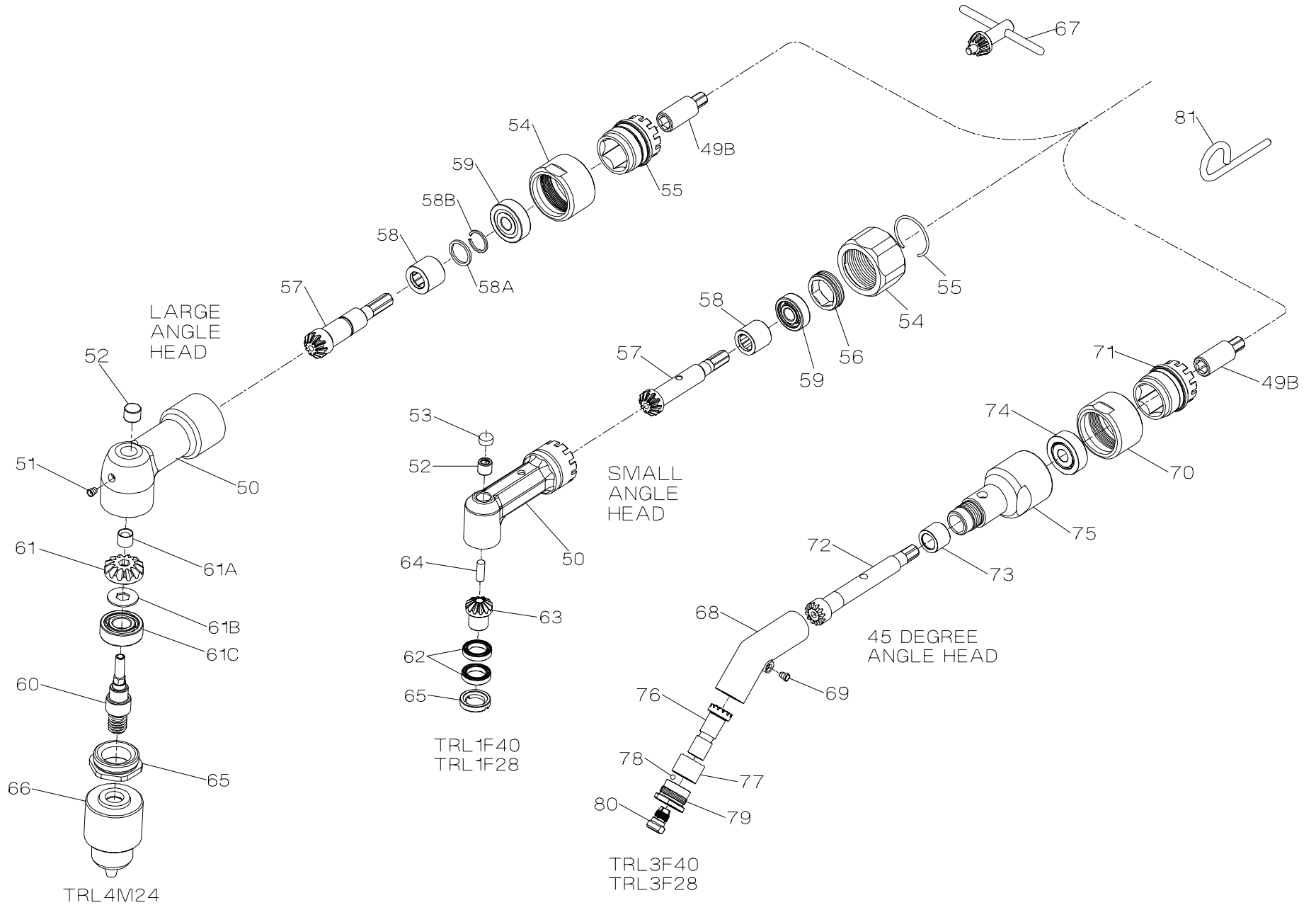

(Dwg. TPA1824)



## ANGLE HEADS FOR SERIES QA ANGLE DRILLS

PART NUMBER FOR ORDERING

PART NUMBER FOR ORDERING

42	Gear Case .....	TAL-37	57	Bevel Pinion	
43	Spindle Bearing .....	TRH-510		for large angle head .....	48181-1
44	Spindle Bearing Retaining Ring .....	4E-6		for small angle head .....	TRL1-552
45	Spindle Bearing Seat .....	TRH-208	58	Pinion Front Bearing	
46	Housing Grip .....	TRH-40-A136		for large angle head .....	48202-1
47	Nameplate .....	TRH-301		for small angle head .....	TRL-654
48	Warning Label .....	TRH-99	58A	Bearing Spacer (for large angle head) .....	46742
49	Housing Lock Spacer .....	TRL-682	58B	Bearing Spacer Retainer (for large angle head) ....	Y110-5
49A	Grip Spacer .....	TRL-504	59	Pinion Rear Bearing	
49B	Shaft Coupler (for large and 45° angle heads) .....	TRL1-213		for large angle head .....	Y65-8
	90° Angle Head Assembly			for small angle head .....	TRL-514
	for Models with large angle head and 3/8"-24 male thread for 1/4" drill chuck (Chuck not included in Assembly) ....	TRL4M24	60	Spindle Assembly (for TRL4M24 only) .....	48213-1
	for Models with small angle head and 9/32"-40 female thread for 3/16" collet (Collet not included in Assembly) .....	TRL1F40	61	Bevel Gear .....	46735
	for Models with small angle head and 1/4"-28 female thread Spindle .....	TRL1F28	61A	Bevel Gear Retainer .....	47600
50	Angle Housing		61B	Bevel Gear Spacer .....	47694
	for large angle head .....	48203-1	61C	Spindle Lower Bearing .....	Y65-13
	for small angle head .....	TRL1-550	62	Spindle Lower Bearing (for small angle heads only) (2) .....	TRL1-593
51	Grease Fitting (for large angle head only) .....	35967	63	Spindle	
*	Angle Housing Cover (for large angle head only) ..	48192-1	64	for TRL1F40 Angle Head Assembly ....	TRL1-551-F40
52	Spindle Upper Bearing		65	for TRL1F28 Angle Head Assembly ....	TRL1-551-F28
	for large angle head .....	46750		Spindle Upper Bearing Shaft (for small angle heads only) .....	TRL1-110
	for small angle head .....	W22-654	66	Lower Spindle Bearing Cap	
53	Spindle Upper Bearing Cap (for small angle heads only) .....	TRL2-531	67	for large angle head .....	48187-1
54	Coupling Nut			for small angle head .....	TRL1-531
	for large angle head .....	48185-1		Drill Chuck (1/4" for large angle head only) .....	R0H-99
	for small angle head .....	TRL-27		Chuck Key .....	R1H-J253
55	Coupling Nut Retainer			45° Angle Head Assembly	
	for large angle head .....	TRL1-305		for Models with small angle head and 9/32"-40 female thread for 3/16" collet (Collet not included in Assembly) .....	TRL3F40
	for small angle head .....	TRL-29	68	for Models with small angle head and 1/4"-28 female thread Spindle .....	TRL3F28
56	Angle Head Plug (for small angle heads only) .....	TRL1-532	69	Angle Housing .....	43833-1
				Grease Fitting .....	35967

\* Not illustrated.



PART NUMBER FOR ORDERING



PART NUMBER FOR ORDERING



70	Coupling Nut . . . . .	48185-1	77	Spindle Lower Bearing . . . . .	44424
71	Coupling Nut Retainer . . . . .	TRL1-305	78	Lower Spindle Bearing Cap Ball (11) . . . . .	Y16-203
72	Bevel Pinion . . . . .	48836-1	79	Lower Spindle Bearing Cap . . . . .	48840-1
73	Pinion Front Bearing . . . . .	46222	80	Collet Insert (for TRL3F40 Angle Head Assembly) . . . . .	43497-169
74	Pinion Rear Bearing . . . . .	Y65-8	81	Wrench Pin . . . . .	48182-1
75	Pinion Housing . . . . .	48196-1	*	Suspension Bail . . . . .	7L-365
76	Spindle		*	Piped-Away Exhaust Kit (optional) . . . . .	LG1-K284
	for TRL3F40 Angle Head Assembly . . . . .	48838-1			
	for TRL3F28 Angle Head Assembly . . . . .	48837-1			

\* Not illustrated.

## MAINTENANCE SECTION



**Always wear eye protection when operating or performing maintenance on this tool.**

**Always turn off the air supply and disconnect the air supply hose before installing, removing or adjusting any accessory on this tool, or before performing any maintenance on this tool.**

### LUBRICATION

Each time a Series QA Angle Drill is disassembled for maintenance and repair or replacement of parts, lubricate the tool as follows:

1. Coat all exposed gears with Ingersoll-Rand No. 67 Grease and work some of the Grease into the gearing of the Spindle Assembly (41) and Angle Head Assembly (50 or 68).
2. Use Ingersoll-Rand No. 10 Oil to lubricate the motor. Inject approximately 1 to 2 cc of oil into the air inlet before attaching the air hose to the tool.

### SPEED ADJUSTMENT

Series QA Angle Drills are furnished with the ability to precisely control speed, within certain ranges. Setting the speed requires a tachometer. Although the adjustment is simple, only a competent technician using the proper equipment should attempt it.

The Back Cap (7) has a small, molded stud on the end face of the Cap nearest the Exhaust Diffuser (16). Take an initial reading of the tool speed by applying a tachometer to the end of the Chuck (66) or Spindle (63 or 76) without a drill bit and with the Lever (11) completely depressed. If the tachometer has a concave tip, close the Chuck completely; if the tip is convex, open the Chuck completely.

After determining the actual velocity, shut off the air supply and disconnect the airline. Use a 3/4" wrench to loosen the Inlet Bushing (17). The longest slot in the Exhaust Diffuser will contain the molded stud on the Back Cap. Rotate the Diffuser to open the exhaust ports to increase speed or rotate it to restrict the exhaust to reduce speed. Being careful not to allow the Diffuser to damage the molded stud, tighten the Inlet Bushing to 15 ft-lbs. (20 Nm) torque. Connect the airline and restore the air supply and check the velocity again. Determine which direction you need to rotate the Diffuser to obtain the desired speed and then rotate it accordingly. Best results are achieved by using gradual increments and frequent tachometer readings. Be sure to turn off the air supply and disconnect the line when making adjustments.

### DISASSEMBLY

#### General Instructions

1. Do not disassemble the tool any further than necessary to replace or repair damaged parts.
2. Whenever grasping a tool or part in a vise, always use leather-covered or copper-covered vice jaws to protect the surface of the part and help prevent distortion. This is particularly true of threaded members and housings.
3. Do not remove any part that is a press fit in or on a subassembly unless the removal of that part is necessary for repairs or replacement.
4. Do not disassemble the tool unless you have a complete set of gaskets and o-rings for replacement.

#### Disassembly of the Tool

Each Series QA Angle Drill is composed of four modules including a housing and throttle unit, a motor unit, a combined gearing with spindle unit and an angle head unit. The tool can be disassembled for repairs to each individual unit without disturbing the other units. To separate the modules, proceed as follows:

1. Remove the Chuck (66) using the following technique:
  - a) Insert the short leg of a 1/4" hex wrench into the jaws of the Chuck and tighten the Chuck.
  - b) Using a brass hammer, sharply rap the long leg of the wrench in a counterclockwise direction to loosen the Chuck.
  - c) Unscrew and remove the Chuck from the spindle.
2. Lightly grasp the body portion of the Angle Head (50 or 68) in copper-covered or leather-covered vise jaws in a manner that provides access to the Coupling Nut (54 or 70).

### NOTICE

**The Coupling Nut has a left-hand thread. Rotate the Nut clockwise to loosen it.**

3. Using a wrench on the flats of the Coupling Nut, loosen the Coupling Nut and then remove the tool from the vise jaws.
4. With the Angle Head upward, unscrew the Coupling Nut and pull the assembled Angle Head off the front end of the tool. Remove the Housing Lock Spacer (49) from the Angle Head or Gear Case (42).
5. Remove the Grip Spacer (49A) and pull the Grip Assembly (46) off the Gear Case.
6. **For large and 45° angle heads**, remove the Shaft Coupler (49B) from the Bevel Pinion (57 or 72) or the Spindle (41).
7. Lightly grasp the flats of the Motor Housing in leather-covered or copper-covered vise jaws with the Inlet Bushing (17) upward.

## MAINTENANCE SECTION

8. Place a 1–3/16” wrench on the flats of the Back Cap (7) to prevent it from rotating, and use a 3/4” wrench to unscrew and remove the Inlet Bushing.
9. Lift the Exhaust Diffuser (16) off the Back Cap.
10. If the Throttle Valve Spring (15) did not come out of the tool with the Inlet Bushing, use needle nose pliers to remove it and the Throttle Valve (14) from the Motor Housing.
11. If the Throttle Valve Seat (13) is damaged and must be replaced, insert a hooked tool through the central opening of the Seat and pull it from the Motor Housing.
12. Using a 1/16” pilot punch, tap the Throttle Lever Pin (12) out of the Back Cap and remove the Throttle Lever (11).
13. Pull the Throttle Plunger (6) out of the Motor Housing and remove the assembly from the vise.
14. Holding the assembly horizontally, remove the Back Cap, the Memory Chip (10) (if included with the tool), and the Back Cap Gasket (8).
15. If the Muffler Elements (9) need to be cleaned or replaced, pull them out of the Back Cap.
16. Grasp the flats at the inlet end of the Motor Housing in leather-covered or copper-covered vise jaws, and using a 1–1/16” wrench on the flats of the Gear Case, unscrew and remove the Gear case from the Motor Housing.
17. Set the assembled Gear Case on the workbench.
18. Remove the Motor Clamp Washer (33) and the Motor Seal (32) from the assembled motor in the Housing.
19. Tap the Motor Housing on a block of wood to remove the motor assembly from the Motor Housing.

### Disassembly of the TRL4M24 Angle Head

1. Carefully grasp the assembled Angle Head in leather-covered or copper-covered vise jaws with the Coupling Nut Retainer (55) upward.

#### NOTICE

**The thread in the following step is a left-hand thread. Rotate the Coupling Nut Retainer counterclockwise to loosen it.**

2. Insert a piece of flat stock into the slots of the Coupling Nut Retainer for leverage, and unscrew and remove the Retainer.
3. Lift the Coupling Nut (54) off the Angle Head (50).
4. Pull the assembled Bevel Pinion (57) out of the Angle Head.
5. Pull the Pinion Rear Bearing (59) off the shaft of the Bevel Pinion.
6. Use a thin blade screwdriver to pry the Bearing Spacer Retainer (58B) out of the groove on the shaft

of the Bevel Pinion and slide the Bearing Spacer (58A) off the Bevel Pinion.

7. Pull the Pinion Front Bearing (58) off the shaft of the Bevel Pinion.
8. Reposition the Angle Head in the vise jaws with the Spindle Assembly (60) upward.

#### NOTICE

**The thread in the following step is a left-hand thread. Rotate the Bearing Cap counterclockwise to loosen it.**

9. Using a wrench on the flats of the Bearing Cap, unscrew and remove the Lower Spindle Bearing Cap (65).
10. Pull the Spindle Assembly out of the Angle Head.
11. Install a bearing separator between the Bevel Gear Retainer (61A) and the Bevel Gear (61) and press the Spindle Assembly out of the Retainer.
12. Lift the Bevel Gear and Bevel Gear Spacer (61B) off the shaft of the Spindle.
13. Pull the Spindle Lower Bearing (61C) off the shaft of the Spindle.
14. Remove the Angle Head from the vise jaws.
15. If the Spindle Upper Bearing (52) must be replaced, press the Bearing out the end of the Angle Head opposite the spindle end.

### Disassembly of the TRL1F40 and TRL1F28

#### Angle Heads

1. Slide the Coupling Nut (54) toward the output end of the Angle Head (50) and using a thin blade screwdriver, work the Coupling Nut Retaining Ring (55) out of the groove in the Angle Head. Slide the Coupling Nut off the Angle Head.
2. Using a piece of 9/16” hexagon bar stock with a 1/4” hole drilled 3/4” deep in the center to clear the hex of the Bevel Pinion (57) and a 9/16” wrench, unscrew and remove the Angle Housing Plug (56).
3. To pull the assembled Bevel Pinion out of the Angle Head, proceed as follows:
  - a) Gather together a 1/2” square drive socket that would be used for a nut that is larger than one inch and an 8–32 UNC socket head cap screw that is one half inch longer than the socket. In addition, a nut for the Screw and a flat washer that is larger than the socket with a hole that is smaller than the nut, yet is thick enough to withstand some pressure, are also necessary. A wrench for the nut and a hex wrench for the screw are also required.
  - b) Thread the nut onto the cap screw until it stops against the screw head.

## MAINTENANCE SECTION

- c) To restrict the rotation of the small angle head Spindle (63), thread a 1/4"–28 thread bolt into the Spindle or insert a rod into the collet and clamp the bolt or rod into a vise with the motor end upward.
  - d) Place the square drive end of the socket against the notched end of the Angle Head.
  - e) With the cap screw and nut inserted through the flat washer, thread the cap screw through the square drive opening into the end of the Bevel Pinion until it bottoms out.
  - f) Thread the nut along the cap screw until it contacts and holds the flat washer against the Angle Head.
  - g) Use a hex wrench to hold the cap screw in position while turning the nut with a wrench to jack the assembled Bevel Pinion out of the Angle Head. Unscrew the cap screw from the Bevel Pinion.
4. Slide the Pinion Rear Bearing (59) and Pinion Front Bearing (58) off the Bevel Pinion.
  5. Grasp the Angle Housing lightly in copper-covered or leather-covered vise jaws with the Spindle upward.

### NOTICE

**The thread in the following step is a left-hand thread. Rotate the wrench clockwise to remove the Cap.**

6. Use a fixed or adjustable face spanner wrench to unscrew and remove the Lower Spindle Bearing Cap (65).
7. Pull the assembled Spindle out of the Angle Head.
8. Slide the two Spindle Lower Bearings (62) off the Spindle.
9. To remove the Spindle Upper Bearing Shaft (64), stand the gear end of the Spindle on a block with clearance for the Shaft. Insert a 1/8" round rod into the opening in the output end of the Spindle and using an arbor press, press the Shaft out of the Spindle.
10. If the Spindle Upper Bearing (52) must be replaced, press the Bearing and Spindle Upper Bearing Cap (53) out the end of the Angle Housing opposite the spindle end.

### Disassembly of the TRL3F40 and TRL3F28

#### Angle Heads

1. Carefully grasp the assembled Angle Head (68) in leather-covered or copper-covered vise jaws with the Coupling Nut Retainer (71) upward.

### NOTICE

**The thread in the following step is a left-hand thread. Rotate the Coupling Nut Retainer counterclockwise to loosen it.**

2. Using a wrench on the flats of the Pinion Housing (75) to prevent it from turning, and placing a piece of flat stock into the slots of the Coupling Nut Retainer for leverage, unscrew and remove the Retainer.
3. Lift the Coupling Nut (70) off the Angle Head (68).

### NOTICE

**The thread in the following step is a left-hand thread. Rotate the Pinion Housing counterclockwise to loosen it.**

4. Using a wrench on the flats of the Pinion Housing, unscrew and remove the Housing from the Angle Head.
5. Grasp the gear end of the Bevel Pinion (72) in copper-covered vise jaws and, being careful not to drop the Pinion Rear Bearing (74), pull the Housing off the Pinion.
6. Pull the Pinion Rear Bearing out of the Pinion Housing and the Pinion Front Bearing (73) off the shaft of the Bevel Pinion.
7. Reposition the Angle Head in the vise jaws with the Lower Spindle Bearing Cap (79) upward.

### NOTICE

**The thread in the following step is a left-hand thread. Rotate the Lower Spindle Bearing Cap counterclockwise to loosen it.**

8. Using a wrench on the flats of the Bearing Cap, loosen, but do not remove, the Lower Spindle Bearing Cap.
9. Remove the Angle Head from the vise jaws and while holding it over a pasteboard container, unscrew and remove the Bearing Cap. Make certain the eleven Lower Spindle Bearing Cap Balls (78) fall into the container and not onto a hard surface.
10. Pull the Spindle (76) out of the Angle Head and pull the Spindle Lower Bearing (77) off the shaft of the Spindle.

## MAINTENANCE SECTION

### Disassembly of the Gearing

1. Using snap ring pliers, remove the Gear Retainer (34) from inside the Gear Case (42) and remove the Gear Head Spacer (35).
2. **For Series QA171, QA21, QA27 and QA35**, lightly rap the motor end of the Gear Case on a wooden work bench top to remove the Planet Gear Head Drive Plate (36), Planet Gear Head Assembly (37) and the Planet Gear Head Spacer (40).  
**For Series QA05, QA083 and QA085**, lightly rap the motor end of the Gear Case on a wooden work bench top to remove the three Planet Gears (38), the Planet Gear Head Assembly (37) and the Planet Gear Head Spacer (40).  
**For Series QA081, QA12, QA173 and QA175**, lightly rap the motor end of the Gear Case on a wooden work bench top to remove the three Planet Gears (38), the Gear Head Pinion (39), the Planet Gear Head Assembly (37) and the Planet Gear Head Spacer (40).
3. Using snap ring pliers, remove the Spindle Bearing Retaining Ring (44).
4. Stand the Gear Case on the table of an arbor press with the output spindle upward. Using a rod that neatly fits inside the internal hex of the Spindle (41), press the Spindle Assembly out of the Spindle Bearing (43).

### CAUTION

**Do not remove the Bearing in the following step unless you have a new replacement available for installation. The Bearing will be damaged as a result of the removal process.**

5. Invert the Gear Case on the table of an arbor press so that the end face having the four notches makes contact with the table. Using a rod against the inner race of the Spindle Bearing, press the Bearing from the Gear Case.
6. If the Spindle Bearing Seat (45) must be replaced, use a small, thin blade screwdriver to spiral it out of the groove in the Gear Case.

### Disassembly of the Motor

1. If the motor was not removed from the Housing (1) when the tool was disassembled, slide the Motor Clamp Washer (33) off the shaft of the Rotor (27) and remove the Motor Seal (32).
2. Tap the Motor Housing on a block of wood to remove the motor assembly from the Motor Housing.

3. Using snap ring pliers, remove the Rear End Plate Assembly Retainer (23) from the shaft of the Rotor.
4. Pull the Rear End Plate Face Plate (22) and Rear End Plate Assembly (21) off the hub of the Rotor.
5. Using a piece of leather or other type of protective material, grasp the shaft of the Rotor and pull the Rotor out of the Cylinder (24).
6. Remove the Vanes (28) from the Rotor.
7. Support the Front End Plate Assembly (29), as near the rotor body as possible, on the table of an arbor press and press the Rotor from the Front Rotor Bearing (31). Remove the Bearing from the Front End Plate.

### Disassembly of the Housing

1. Pull the Housing Plug Cover (20) off the inlet end of the Motor Housing (1).
2. If the Housing Plug (3) does not drop out of the Housing when the Cover is removed, tap the inlet end of the Housing on a block of wood to dislodge the Plug from the Housing.
3. Insert a 5/16" wooden dowel between 6 and 8 inches long, into the inlet end of the Motor Housing and push the Reverse Valve Assembly (4) out the motor end of the Housing.
4. Use a hooked tool to pull the Housing O-ring (2) out of the Motor Housing.

## ASSEMBLY

### General Instructions

1. Always press on the **inner** ring of a ball-type bearing when installing the bearing on a shaft.
2. Always press on the **outer** ring of a ball-type bearing when pressing the bearing into a bearing recess.
3. Whenever grasping a tool or part in a vise, always use leather-covered or copper-covered vise jaws to protect the surface of the part and help prevent distortion. This is particularly true of threaded members and housings.
4. Except for bearings, always clean every part and wipe every part with a thin film of oil before installation.
5. Apply o-ring lubricant to all o-rings before final assembly.
6. Check every bearing for roughness. If an open bearing must be cleaned, wash it thoroughly in a clean, suitable cleaning solution and dry with a clean cloth. **Sealed or shielded bearings should never be cleaned.** Lubricate all open bearings with grease before installation.

## MAINTENANCE SECTION

### Assembly of the Housing

1. Lubricate the Housing O-ring (2) with o-ring lubricant and install it at the bottom of the cylinder bore in the Motor Housing (1).
2. Inspect the face and Reverse Valve Seal (5) on the hub of the Reverse Valve Assembly (4) for nicks or damage. Replace the Reverse Valve Assembly or Seal if any damage is evident.
3. Lubricate the Reverse Valve Seal with o-ring lubricant and insert the Assembly, seal end leading, into the cylinder bore of the Motor Housing. Push the Assembly toward the bottom of the cylinder bore until it "snaps" into its proper location.
4. Rotate the Valve inside the Housing until the threaded hole into the side of the Valve aligns with the hole for the Housing Plug (3) in the side of the Motor Housing.
5. Insert the pin end of the Housing Plug into the hole in the Reverse Valve and fit the remainder of the Plug into the recess in the Motor Housing.
6. While holding the Plug in position, from the inlet end of the Housing, slide the Housing Plug Cover (20) onto the Housing. Make certain it captures the Plug when it moves along the Housing and stops against the housing shoulder.

### Assembly of the Motor

1. Place the Front End Plate (29) on the splined shaft of the Rotor (27) with the bearing recess away from the rotor body.
2. Place the Front Rotor Bearing (31) onto the shaft and using a sleeve or piece of tubing that makes contact with the inner race of the Bearing, press the Bearing onto the shaft until the Front End Plate nearly contacts the rotor body.

#### NOTICE

**In the following step, the measurement must be made at the end corner of the large rotor body.**

3. The clearance between the Front End Plate and Rotor is critical. While pressing downward with your finger on the outer edge of the Front End Plate on the bearing side of the End Plate, insert a 0.004" (0.1 mm) feeler gauge between the face of the rotor body and the face of the End Plate at a point that is 180 degrees away from where the pressure is applied. Refer to Dwg. TPA1740. To increase the gap, support the End Plate and lightly tap the rotor shaft with a plastic hammer; to decrease the gap, press the Bearing farther onto the rotor shaft.

### Measurement of Front End Plate Clearance

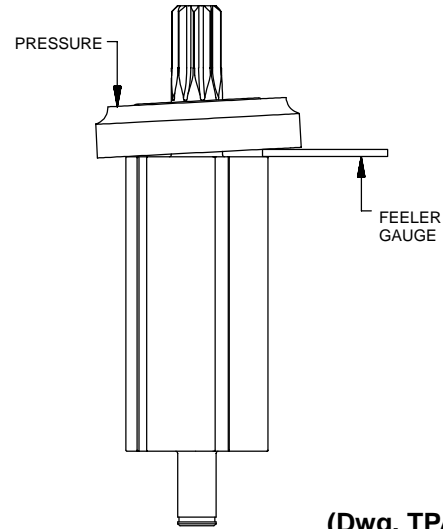

4. Wipe each Vane (28) with a light film of Ingersoll-Rand No.10 Oil and place a Vane in each slot in the Rotor.
5. One end of the Cylinder Assembly (24) has a notch that breaks the outer wall and end face of the Cylinder. With that end trailing, install the Cylinder Assembly over the Rotor and Vanes against the Front End Plate. Make certain the Cylinder Front Alignment Pin (26) enters the hole in the Front End Plate.
6. Install the Rear End Plate Assembly (21), flat face leading, on the rear hub of the Rotor. Make certain the Cylinder Rear Alignment Pin (25) enters the hole in the Rear End Plate.
7. Examine the Rear End Plate Face Plate (22) for scratches. If it is scratched, replace it. If it is not, slide it onto the rear hub of the Rotor and onto the Cylinder Rear Alignment Pin against the Rear End Plate. Some pressure may be required to fit the hole in the Plate onto the Alignment Pin.
8. Using snap ring pliers, install the Rear End Plate Assembly Retainer (23) in the annular groove on the rear rotor hub to secure the assembly in position.
9. Set the assembled motor aside.

### Assembly of the Gearing

1. Using a small screwdriver, work the Spindle Bearing Seat (45) into the internal groove nearest the notched end of the Gear Case (42).
2. Stand the Gear Case, notched end upward, on the table of an arbor press. Using a piece of tubing that contacts the outer race of the Spindle Bearing (43), press a new Bearing into the Gear Case against the Seat.

## MAINTENANCE SECTION

- Lubricate the gears in the Spindle Assembly (41) with Ingersoll–Rand No. 67 Grease.
- Invert the Gear Case and using another piece of tubing that supports the inner race of the Bearing and clears the output end of the Spindle Assembly, press the Spindle Assembly into the Bearing from the motor end of the Gear Case.
- Using snap ring pliers, install the Spindle Bearing Retainer (44) in the external groove near the drive end of the spindle.
- Apply some Ingersoll–Rand No. 67 Grease to the Planet Gear Head Spacer (40) and the shafts of the Planet Gear Head Assembly (37).
- Insert the Planet Gear Head Spacer (39) and Planet Gear Head Assembly (36), spline hub leading, into the open end of the Gear Case.
- For Series QA05, QA08, QA12, QA173 and QA175**, apply Ingersoll–Rand No. 67 Grease to the three Planet Gears (38) and install them on the shafts of the Planet Gear Head Assembly.
- For Series QA081, QA12, QA173 and QA175**, apply Ingersoll–Rand No. 67 Grease to the Gear Head Pinion (39) and while meshing the gear teeth, insert it in the opening between the three Planet Gears.
- For Series QA171, QA21, QA27 and QA35**, install the Planet Gear Head Drive Plate (36) on the shafts of the Planet Gear Head Assembly.
- Place the Gear Head Spacer (35) in the Gear Case and secure the assembly by using snap ring pliers to install the Gear Retainer (34) in the annular groove inside the Gear Case.
- Using a piece of tubing that clears the shaft of the Spindle, press the Bevel Gear Retainer (61A) onto the shaft to secure the assembly.
- Insert the assembled Spindle into the Angle Head making certain that shaft of the Spindle enters the Spindle Upper Bearing.

### NOTICE

**The thread in the following step is a left-hand thread. Rotate the Bearing Cap clockwise to tighten it.**

- Thread the Spindle Bearing Cap (65) into the Angle Head and tighten it.
- The location of the Pinion Front Bearing (58) on the Bevel Pinion (57) is critical. Using a sleeve that clears the front bearing inner race shaft and is between 0.595” and 0.605” (15.1 and 15.3 Nm) long, push the Bearing onto the shaft of the Pinion until the trailing end of the sleeve is flush with the end of the front bearing inner race shaft.
- Slide the Bearing Spacer (58A) onto the Bevel Pinion and install the Bearing Spacer Retainer (58B) in the annular groove on the shaft of the Bevel Pinion.
- Apply approximately 1/8 oz. (3.5 g) of Ingersoll–Rand No. 67 Grease to the gear end of the Bevel Pinion and insert the assembly into the Angle Head.
- Install the Pinion Rear Bearing (59) over the shaft of the Bevel Pinion and push the Bearing into the Angle Head recess against the shoulder of the Pinion. Apply pressure to the outer race of the Bearing.
- Install the Coupling Nut (54) with the internal threaded end trailing, on the Angle Head.

### NOTICE

**The thread in the following step is a left-hand thread. Rotate the Coupling Nut Retainer clockwise to tighten it.**

- Thread the Coupling Nut Retainer (55) into the Angle Head and tighten it.

### Assembly of the TRL4M24 Angle Head

- If the Spindle Upper Bearing (52) was removed, position the spindle end of the Angle Head (50) on the table of an arbor press. Press a new Bearing into the Head until it is flush with the top of the housing.
- Install the Spindle Lower Bearing (61C), followed by the Bevel Gear Spacer (61B) and the Bevel Gear (61), gear end trailing, onto the shaft of the Spindle (60).

## MAINTENANCE SECTION

### Assembly of the TRL1F40 and TRL1F28 Angle Heads

1. If the Spindle Upper Bearing (52) was removed, stand the output end of the Angle Head (50) on the table of an arbor press. Using a Needle Bearing Inserting Tool as shown in Dwg. TPD786, press the Bearing into the small opening at the top of the Angle

#### Needle Bearing Inserting Tool

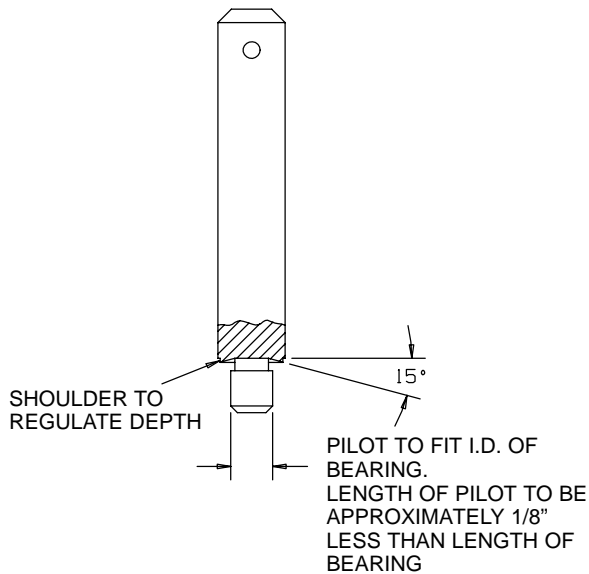

(Dwg. TPD786)

2. Apply a light film of Ingersoll-Rand No. 67 Grease to the shaft of the Bevel Pinion (57) and to the inside of the Pinion Front Bearing (58).
3. Slide the Pinion Front Bearing, stamped end trailing, onto the shaft until it stops against the back of the gear.
4. Without distorting the Angle Head, support the hex flats of the Angle Head in a machine vise on the table of an arbor press with the notched end upward and the Head resting on a solid stop. Apply 2 to 4 cc of Ingersoll-Rand No. 67 Grease to the gear on the end of the Bevel Pinion.
5. Insert the gear end of the Bevel Pinion into the notched end of the Angle Head while aligning the Pinion Front Bearing with the central opening.
6. Use a piece of tubing that clears the shaft of the Bevel Pinion and the inner wall of the Angle Head and is between 1.455" and 1.465" (36.95 and 37.21 mm) long to press the Bearing into the Angle Head. Press the Bearing until the trailing end of the pressing tube is flush with the notched end of the Angle Head.
7. Apply some Ingersoll-Rand No. 67 Grease to the Pinion Rear Bearing (59) and slide it onto the shaft of the Bevel Pinion and into the Angle Head recess.

8. Use the 9/16" hex stock with clearance for the bevel pinion shaft that was used during disassembly to screw the Angle Head Plug (56) into the Angle Head against Pinion Rear Bearing. Tighten the Plug between 8 and 12 ft-lbs. (10.8 and 16.2 Nm) torque.
9. Remove the assembly from the machine vise and position it in leather-covered or copper-covered vise jaws with the opening for the output spindle upward.
10. If the Spindle Upper Bearing Shaft (64) was removed, stand the output end of the Spindle (63) on the table of an arbor press. One end of the Shaft has a bevel and the other end is rounded. Press the Shaft, bevel end leading, into the gear end of the Spindle until the rounded end protrudes between 0.250" and 0.260" (6.35 and 6.60 mm) above the face of the gear.
11. Slide the Spindle Lower Bearing (62) onto the shaft of the Spindle against the gear and insert the assembled Spindle, gear end leading, into the Angle Head. Push the Bearing into the housing below the threads.
12. Thread the Lower Spindle Bearing Cap (65) into the Angle Head and using a spanner wrench, tighten the Cap between 18 and 20 ft-lbs. (24.4 and 27.1 Nm) torque.
13. Remove the assembly from the vise jaws and slide the Coupling Nut (54), threaded end trailing, onto the notched end of the Angle Head. Move the Nut far enough onto the housing to install the Coupling Nut Retainer (55) in the annular groove at the notched end of the Angle Head.

### Assembly of the TRL3F40 and TRL3F28 Angle Heads

1. Push the Spindle Lower Bearing (77) onto the shaft of the Spindle (76) against the gear head.
2. Apply some grease to the annular groove on the shaft of the Spindle. Position the output end of the shaft inside the Lower Spindle Bearing Cap (79) with the leading edge of the shaft groove slightly below the end of the Cap. Insert the eleven Lower Spindle Bearing Cap Balls (78) into the shaft groove and when all the Balls are in position, allow the Cap to move forward on the Spindle to capture the Balls between the Cap and shaft.

#### NOTICE

**The thread in the following step is a left-hand thread. Rotate the Spindle Bearing Cap clockwise to tighten it.**

3. Insert the assembled Spindle into the output end of the Angle Head (68) and thread the Spindle Bearing Cap into the housing. Using a wrench on the flats of the Bearing Cap, tighten the Cap in the Angle Head.
4. Slide the Pinion Front Bearing (73) onto the shaft of the Bevel Pinion (72) until it is against the gear head.



## MAINTENANCE SECTION

5. Insert the hex end of the Bevel Pinion into the small end of the Pinion Housing (75). Apply 2 to 4 cc of Ingersoll–Rand No. 67 Grease to the gear end of the Bevel Pinion.

### NOTICE

**The thread in the following step is a left–hand thread. Rotate the Pinion Housing clockwise to tighten it.**

6. Insert the gear end of the Bevel Pinion into the Angle Head and thread the Pinion Housing into the Angle Head. Using a wrench on the flats of the Pinion Housing, tighten the joint.
7. Install the Pinion Rear Bearing (74) over the shaft of the Bevel Pinion and push the Bearing into the Pinion Housing recess until it stops. Apply pressure to the outer race of the Bearing.
8. Install the Coupling Nut (70) with the internal threaded end trailing, on the Pinion Housing.

### NOTICE

**The thread in the following step is a left–hand thread. Rotate the Coupling Nut Retainer clockwise to tighten it.**

9. Thread the Coupling Nut Retainer (71) into the Pinion Housing and tighten it.

### Assembly of the Tool

1. Lightly grasp the flats on the Motor Housing (1) in leather–covered or copper–covered vise jaws with the inlet end of the tool upward.
2. Insert a 5/8” dowel through the opening in the Back Cap (7), and using the dowel as an alignment device, install the three Muffler Elements (9) in the cavity of the Back Cap. Make certain the notches in the outer edge of the Elements fit over the memory chip pocket in the bottom of the Cap.
3. **If the tool is equipped with a Memory Chip (10)**, install it (with the leads entering first) in the pocket at the bottom of the Back Cap.
4. Make certain the tab on the inside edge of the Back Cap Gasket (8) is aligned with the pocket for the Memory Chip and install the Gasket, metal face leading, in the recess of the Back Cap against the face with the cavity containing the Muffler Elements.
5. Position the gasket end of the alignment dowel against the inlet hub on the Motor Housing. Align the flats on the Cap with the flats on the Housing. Orient the Back Cap and slide the Back Cap Assembly off the alignment dowel and onto the Motor Housing.
6. The Exhaust Diffuser (16) has one slot that is longer than the other five slots. The Back Cap has a short, molded stud projecting from inlet end. Place the

Exhaust Diffuser against the Back Cap with the long slot encircling the molded stud. Rotate the Diffuser counterclockwise until the wall of the slot stops against the stud. The exhaust ports are now in the full open position and will provide maximum free speed.

7. Being careful not to damage it, insert the Throttle Valve Seat (13) into the central opening at the inlet end of the Motor Housing at an angle until it clears the threads in the Housing. Using a rod with a flat end and no sharp edges, push the Seat to the bottom of the opening until it seats flush.
8. Using needle nose pliers, insert the Throttle Valve (14), long stem leading, into the opening against the Seat. Center the Valve in the Seat.
9. Install the Throttle Valve Spring (15) in the opening so that it encircles the Valve.
10. If the Inlet Screen (19) required replacement, use a wooden dowel to carefully push a new one into the Inlet Bushing (17).
11. If the Inlet Bushing Seal (18) is nicked or damaged, carefully install a new one over the threads of the Inlet Bushing.
12. Thread the Inlet Bushing Assembly through the Diffuser and Back Cap into the Motor Housing. Using a 1–3/16” wrench on the flats of the Back Cap to keep it from turning, tighten the Inlet Bushing between 15 and 20 ft–lbs. (20 and 27 Nm) torque.
13. The Throttle Plunger (6) has a lengthwise flat on the outer edge at one end of the Plunger. Insert the Plunger, flat end first, into the cross–hole in the Housing. Push on the end of the Plunger to make certain it springs back from contact with the stem of the Throttle Valve.
14. Position the Throttle Lever (11) in the slot in the Back Cap and Motor Housing and using a 1/16” diameter rod, align the holes through the Back Cap, Motor Housing and Throttle Lever. While maintaining alignment, install the Throttle Lever Pin (12) in place of the rod by tapping it through all three pieces.
15. Remove the assembled Housing from the vise jaws.
16. Lightly grasp the flats of the Motor Housing in leather–covered or copper–covered vise jaws with the motor bore upward.
17. Grasp the spline of the Rotor (27) in the assembled motor and after aligning the End Plate Alignment Pin (30) with the internal notch in the motor end of the housing bore, insert the assembled motor into the Motor Housing. Make certain the motor is far enough into the Housing to have the undercut below the internal housing thread visible.
18. Lubricate the Motor Seal (32) with o–ring lubricant and install it around the Front End Plate (29) and into the undercut in the Housing.

## MAINTENANCE SECTION

19. Align the tab of the Motor Clamp Washer (33) with the internal notch in the Housing and install it over the rotor hub and End Plate Alignment Pin against the Motor Seal. Make certain the Pin enters the hole in the Washer and the Washer is flat against the Seal.
20. Apply some Ingersoll-Rand No. 67 Grease to the spline on the rotor shaft.
21. Thread the assembled Gear Case (42) and Spindle Assembly (41), gear case end leading, into the Motor Housing and using a 1-1/16" wrench, tighten the joint between 15 and 20 ft-lbs. (20 and 27 Nm) torque.
22. Install the Housing Grip (46), internal slotted end leading, over the motor and Housing and engage the slots in the Grip with the projections on the Housing.
23. Position the Housing Lock Spacer (49) in the Gear Case with the tabs of the Spacer going into the notch openings.
24. **For models with TRL4M24, TRL3F40 and TRL3F28 angle heads**, insert the external hex of the Shaft Coupler (49B) into the hex recess in the Spindle Assembly (41).

### NOTICE

**The thread in the following step has a left-hand thread. Rotate the Nut counterclockwise to tighten it.**

25. Orient the assembled Angle Head to the desired position and insert the notched end of the Angle Head into the Gear Case to engage the tabs of the Spacers. Make certain the external hex of the Bevel Pinion (57 or 72) enters the hex recess of the Shaft Coupler (49B) or Spindle Assembly (41). Thread the Coupling Nut (54) onto the Gear Case and tighten it between 2 and 5 ft-lbs. (2.7 and 6.8 Nm) torque.
26. **For large angle heads**, remove the tool from the vise jaws and thread the Chuck (66) onto the Spindle. **For small angle heads**, remove the tool from the vise jaws.
27. Check the free speed of the tool using a tachometer and following the instructions in the **SPEED ADJUSTMENT** section of this manual.

## TROUBLESHOOTING GUIDE

Trouble	Probable Cause	Solution
Loss of Power	Low air pressure	Check air supply. For top performance, the air pressure must be 90 psig (6.2 bar/620 kPa) at the inlet.
	Plugged Inlet Bushing Screen	Clean the Inlet Bushing Screen using a clean, suitable cleaning solution. If the Screen cannot be cleaned, replace it.
	Worn or broken Vanes	Replace a <b>complete</b> set of Vanes.
	Worn or broken Cylinder	Replace the Cylinder if it is cracked or if the bore appears wavy or scored.
	Exhaust control restricted	Make certain the Exhaust Diffuser is in the fully open position.
Motor won't run	Motor Clamp Washer binding	Remove the Gear Case make certain the Washer is flat and the Motor Seal is properly positioned.
	Gears binding	Clean and inspect all gearing. Replace any worn or damaged gearing.
Leaky Throttle Valve	Worn Throttle Valve and/or Throttle Valve Seat	Install a new Valve and/or Seat.
	Dirt accumulation on Throttle Valve and/or Throttle Valve Seat	Clean or replace the Throttle Valve and/or Throttle Valve Seat.
Gear Case gets hot	Excessive grease	Clean and inspect Gear Case and gearing parts and lubricate as instructed.
	Worn or damaged parts	Clean and inspect the Gear Case and gearing. Replace worn or broken components.

### NOTICE

**SAVE THESE INSTRUCTIONS. DO NOT DESTROY.**