

MAINTENANCE SECTION COVERING HAND-HELD POWER MODULES FOR SERIES DEA150 TORQUE CONTROL WRENCHES

▲ WARNING



IMPORTANT SAFETY INFORMATION ENCLOSED.

READ ALL THESE INSTRUCTIONS BEFORE PLACING TOOL IN SERVICE OR OPERATING THIS TOOL AND SAVE THESE INSTRUCTIONS.

IT IS THE RESPONSIBILITY OF THE EMPLOYER TO PLACE THE INFORMATION IN THIS MANUAL INTO THE HANDS OF THE OPERATOR.

FAILURE TO OBSERVE THE FOLLOWING WARNINGS COULD RESULT IN INJURY.

Disconnect the Power Cord from the receptacle before performing any maintenance on this tool.



This symbol is to alert the user and service personnel to the presence of uninsulated dangerous voltage that will cause a risk of electric shock.



This symbol is to alert the user and service personnel to the presence of important operating instructions that must be read and understood to prevent personal injury, electrical shock or damage to the equipment.

WHEN USING ELECTRIC TOOLS, BASIC SAFETY PRECAUTIONS SHOULD ALWAYS BE FOLLOWED TO REDUCE THE RISK OF FIRE, ELECTRIC SHOCK AND PERSONAL INJURY, INCLUDING THE FOLLOWING.

PLACING TOOL IN SERVICE

- Use only with Ingersoll-Rand Series Controllers.
- Always operate, inspect and maintain this tool in accordance with all regulations (local, state, federal and country), that may apply to hand held/hand operated electric tools.
- Inspect tool cords periodically and if damaged, have them repaired by an authorized service facility.
- Do not remove any labels. Replace any damaged label.

USING THE TOOL

- Always wear eye protection when operating or performing maintenance on this tool.
- Always wear hearing protection when operating this tool.

- Power tools can vibrate in use. Vibration, repetitive motions, or uncomfortable positions may be harmful to your hands and arms. Stop using any tool if discomfort, tingling feeling or pain occurs. Seek medical advice before resuming use.
- **Guard Against Electric Shock.** Prevent body contact with earthed or grounded surfaces. For example; pipes, radiators, ranges, refrigerator enclosures.
- **Don't abuse Cord.** Never carry tool by cord or yank it to disconnect from receptacle. Keep cord from heat, oil, and sharp edges.
- **Keep work area clean.** Cluttered areas and benches invite injuries.

(Continued on page 2-2)

NOTICE

The use of other than genuine Ingersoll-Rand replacement parts may result in personal injury, decreased tool performance and increased maintenance, and may invalidate all warranties.

Have your tool repaired by a qualified person. This electric tool is in accordance with the relevant safety requirements. Repairs should only be carried out by qualified persons using original spare parts, otherwise this may result in considerable danger to the user.

Repairs should be made only by authorized, trained personnel. Consult your nearest Ingersoll-Rand Authorized Servicenter.

Refer All Communications to the Nearest
Ingersoll-Rand Office or Distributor.

© Ingersoll-Rand Company 1999

Printed in U.S.A.

INGERSOLL-RAND®
PROFESSIONAL TOOLS



WARNING

FAILURE TO OBSERVE THE FOLLOWING WARNINGS COULD RESULT IN INJURY.

USING THE TOOL (Continued)

- **Consider work area environment.** Don't expose power tools and chargers to water. Keep work area well lighted. Do not use tool in explosive or flammable atmospheres.
- **Keep bystanders and children away.** Do not permit unauthorized personnel to operate this tool, or touch tool or cord.
- **Store idle tools.** When not in use, tools should be stored in a dry, high or locked up place, out of reach of children.
- **Don't force tool.** It will do the job better and more safely at the rate for which it was intended.
- **Use the right tool.** Do not force a small tool or attachment to do the job of a heavy-duty tool.
- **Do not use a tool for a purpose for which it is not intended.** Example: Do not use a screwdriver as a drill.
- **Dress properly.** Do not wear loose clothing or jewelry. They can be caught in moving parts. Rubber gloves and non-skid footwear are recommended when working outdoors. Wear protective hair covering to contain long hair.
- **Secure work.** Use clamps or a vise to hold work. Operators often need both hands to perform job functions.
- **Don't overreach.** Keep proper footing, balance, and a firm grip on the tool at all times.
- **Maintain tools with care.** Keep tools clean for better and safer performance. Follow instructions for lubricating and changing accessories. Inspect tool cords periodically and if damaged, have them repaired by an authorized service facility. Inspect extension cords periodically and replace if damaged. Keep handles dry, clean, and free from oil and grease.
- **Remove adjusting keys and wrenches.** Form habit of checking to see that keys and adjusting wrenches are removed from tool before turning it on.
- **Avoid unintentional starting.** Don't carry tool with finger on switch.
- **Do not drop or abuse the tool.**
- **Whenever a tool is not being used, position the Power Switch to the "OFF" position and unplug the power cord.**
- **Stay alert.** Watch what you are doing. Use common sense. Do not operate tool when you are tired.
- **Check damaged parts.** Before further use of the tool, a guard or other part that is damaged should be carefully checked to determine that it will operate properly and perform its intended function. Check for alignment of moving parts, binding of moving parts, breakage of parts, mounting, and any other conditions that may affect its operation. A guard or other part that is damaged should be properly repaired or replaced by an authorized service center unless otherwise indicated elsewhere in this operation manual.
- **Have defective switches replaced by an authorized service center.**
- **Do not use the tool if the switch does not turn it on and off.**
- **Whenever the Angle Head is installed or repositioned, the Throttle Lever must be positioned so that reaction torque will not tend to retain the throttle in the "ON" position.**
- **When installing or removing the output device on any tool, ALWAYS grasp a metal component of the tool while tightening or loosening the Coupling Nut or Spindle Cap. Acceptable clamping locations include, but are not limited to, the hex on the Gear Case, the Tool Hanger, the Torque Reaction Arm or any metal Mounting Plate. NEVER grasp the composite tool body or handle in vise jaws to restrain the torque of the Coupling Nut or Spindle Cap. Such practice will result in damage to the tool.**
- **Do not use power units and gear trains that exceed the capability of the output device.**
- **The Tube Nut Attachment has an opening on the front side for construction and application purposes. DO NOT, under any circumstance place your fingers in this opening.**
- **The Torque Reaction Bar must be positioned against a positive stop. Do not use the Bar as a dead handle and take all precautions to make certain the operator's hand cannot be pinched between the Bar and a solid object.**
- **When operated continuously for long periods of time, Series D Nutrunners may become hot at the spindle end of the tool. Take all precautions necessary to avoid skin contact with the hot surfaces. Prolonged contact may result in burns.**
- **All Series D Torque Control Wrenches and Nutrunners with reverse capability have rotational arrows molded into the housing in the area of the reversing mechanism. When the direction switching device is positioned nearest the molded circular arrow with an "F" in the center, spindle rotation will be forward or clockwise direction. When the direction switching device is positioned nearest the molded circular arrow with an "R" in the center, spindle rotation will be reverse or counterclockwise direction.**
- **Use only impact sockets and accessories. Do not use hand (chrome) sockets or accessories.**

WARNING LABEL IDENTIFICATION

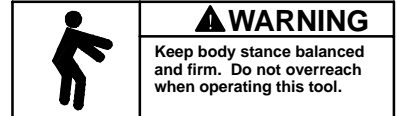
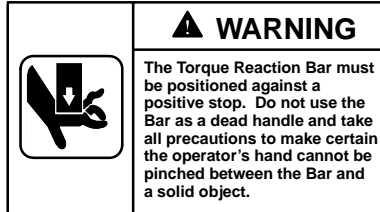
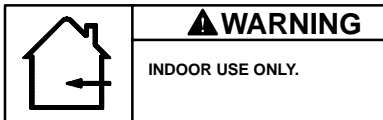
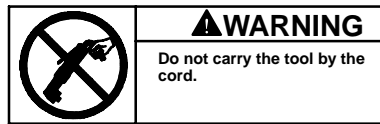
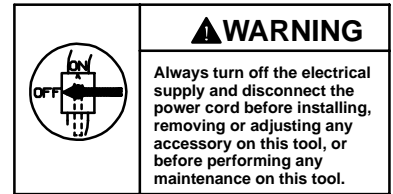
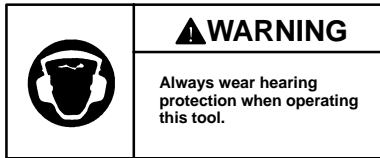
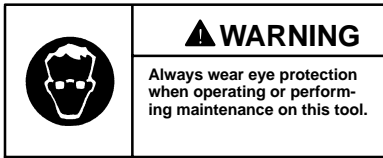

GRIP ADJUSTMENT

The handle of the hand-held Housings have an Adjustable Grip which permits individual operators to select one of three handle thickness positions. Operators with large hands can select the bulkiest position and operators with small hands can select the smallest size. To adjust the Grip, disconnect the power supply and proceed as follows:

1. Grasp the grooved ends of the Adjustable Grip Latch (B), and spreading the ends slightly, raise the Latch to its uppermost position. (Refer to Dwg.TPD1834)

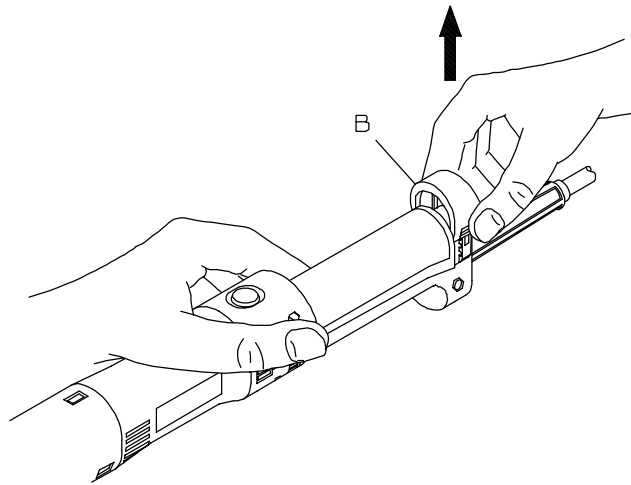

(Dwg. TPD1834)

2. Grasp the Adjustable Grip (A) and slide it rearward until it stops. (Refer to Dwg. TPD1835).

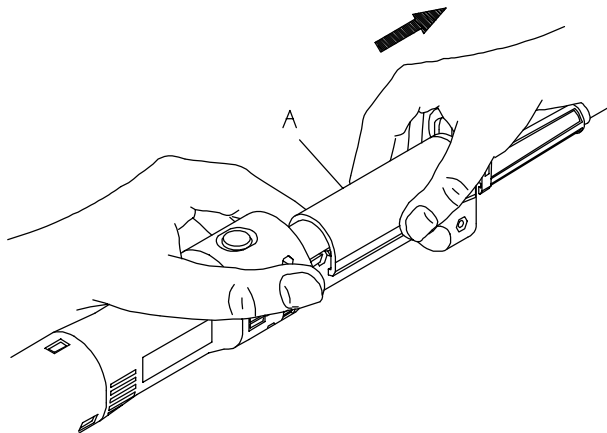

(Dwg. TPD1835)

3. Raise or lower the Grip until the desired grooves inside the Grip align with the appropriate lugs on the Handle. (Refer to Dwg.TPD1836)

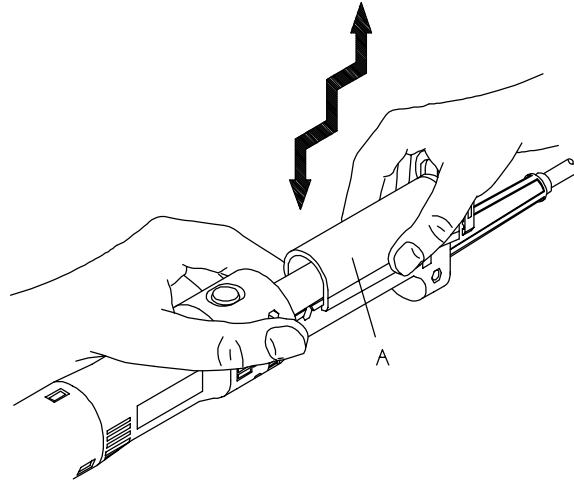

(Dwg. TPD1836)

4. Slide the Grip forward onto the Handle until it butts against the large portion of the handle. (Refer to Dwg.TPD1837)

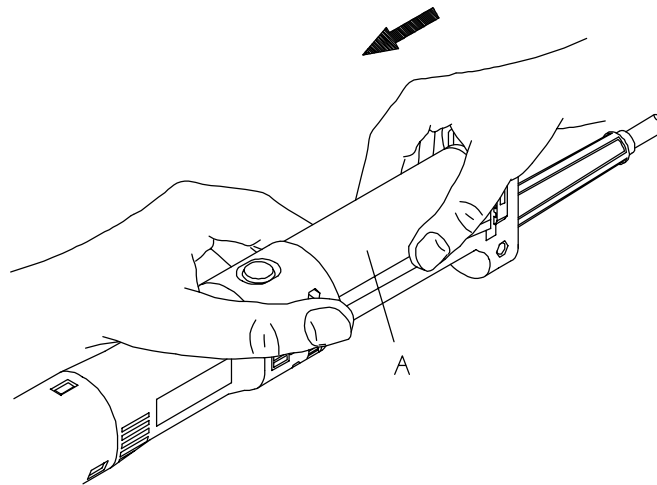

(Dwg. TPD1837)

5. Push the Grip Latch downward to its original position to lock the adjustment into position. (Refer to Dwg.TPD1838)

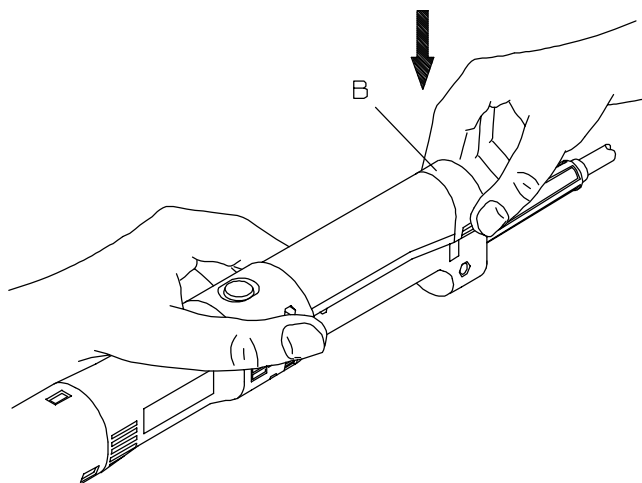

(Dwg. TPD1838)

SERIES DEA150 HAND HELD POWER UNIT

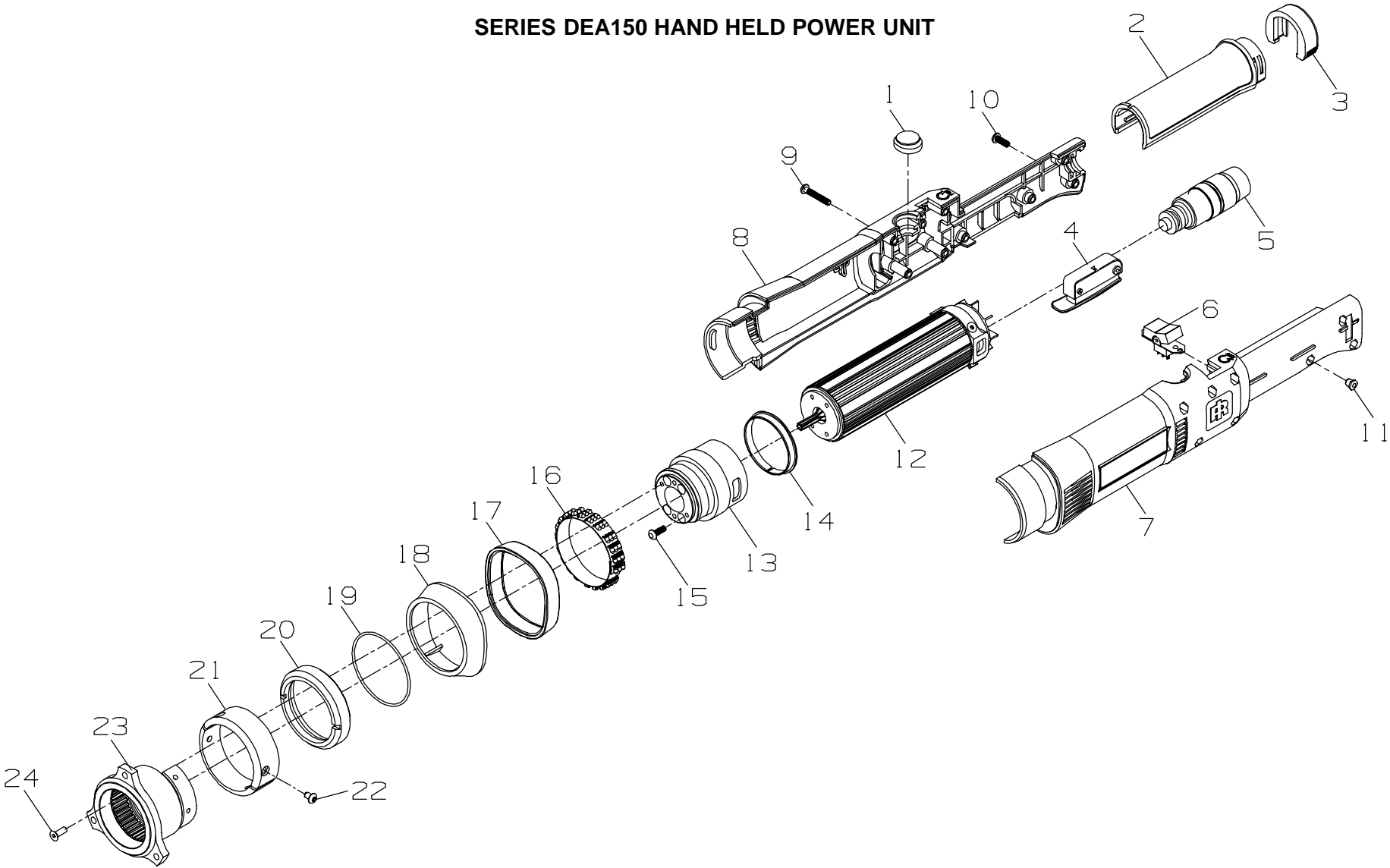

2-5



PART NUMBER FOR ORDERING



PART NUMBER FOR ORDERING



	Motor Housing Assembly	DEA150-A40RC	16	Light Ring	DEA120-98
1	Cable Port Plug	DEA40-701	17	Light Ring Lens	DEA120-600
2	Adjustable Grip	DAA40-30	18	Nose Collar	DEA120-483
3	Adjustable Grip Latch	DAA40-402	19	Nose Collar O-ring	DEA120-798
4	Throttle Switch Assembly	DEA40-A20	20	Nose Collar Retaining Ring	DEA120-482
5	Cable Assembly	DEA150-249R	21	Nose Cover	DEA150-493
6	Reversing Switch Assembly	DEA120-A19	22	Nose Cover Screw (8-31 x 1/4 lg.) (4) ...	DET40-19Z
◆ 7	Left Motor Housing	DEA120-40L	23	Front Coupler	DEA150-491
◆ 8	Right Motor Housing	DEA120-40R	24	Front Coupler Screw (M4 x 0.7 x 10) (4) .	400-35-54
9	Long Housing Screw (M4 x 0.7 x 35) (5) .	DEA120-704			
10	Short Housing Screw (M4 x 0.7 x 12) (4) .	DEA40-703			
11	Housing Screw Nut (9)	DEA40-23			
12	Motor Assembly	DEA150-A22			
13	Motor Adapter	DEA150-492			
14	Motor Clamp Ring	DEA120-440			
15	Adapter Mounting Screw (M4 x 0.7 x 12) (4)	DEA40-703			

◆ When ordering a Left or Right Housing, the complete model number and serial number must be furnished to enable correct labeling of the replacement parts.

WIRING CHART

Connector Pin	Cable Wire Color	Location	Logic
A	Red	Transducer Cable (4 Wire)	(+) Excitation
B	Black		(-) Excitation
C	Green		(+) Signal
D	White		(-) Signal
E	Shield		Shield
F	White	Logic Cable (14 Wire)	Free Speed
G	Green/White		Soft Start
H	Red		(+) 5 Volt
J	Blue/Black		Fwd/Rev
K	Green		Ground Sense
L	Red/Black		Red LED
M	Orange/Black		Yellow LED
N	Green/Black		Green LED
P	Black		Accessory Option
R	Blue/White		PTC Return
S	Black/White	(-) LED/Encoder Common	
T	Blue	Encoder "H2"	
U	Red	Motor	Phase U
V	Black	Power	Phase V
W	White	Leads	Phase W
X	Red/White	Logic Cable	Encoder "H1"
Y	Orange	(14 Wire)	Encoder "H3"
Z	Green	Ground Lead	Ground

NOTICE

SAVE THESE INSTRUCTIONS. DO NOT DESTROY.