

**MAINTENANCE SECTION COVERING
D4850–A237
GEARED OFFSET HEAD
for
SERIES D TORQUE CONTROL WRENCHES
WHEN THIS MODULE IS USED WITH AN ELECTRIC POWERED TOOL**

⚠ WARNING

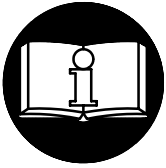

**IMPORTANT SAFETY INFORMATION ENCLOSED.
READ ALL THESE INSTRUCTIONS BEFORE PLACING TOOL IN SERVICE OR
OPERATING THIS TOOL AND SAVE THESE INSTRUCTIONS.
IT IS THE RESPONSIBILITY OF THE EMPLOYER TO PLACE THE INFORMATION
IN THIS MANUAL INTO THE HANDS OF THE OPERATOR.
FAILURE TO OBSERVE THE FOLLOWING WARNINGS COULD RESULT IN INJURY.**

Disconnect the Power Cord from the receptacle before performing any maintenance on this tool.



This symbol is to alert the user and service personnel to the presence of uninsulated dangerous voltage that will cause a risk of electric shock.



This symbol is to alert the user and service personnel to the presence of important operating instructions that must be read and understood to prevent personal injury, electrical shock or damage to the equipment.

**WHEN USING ELECTRIC TOOLS, BASIC SAFETY PRECAUTIONS SHOULD
ALWAYS BE FOLLOWED TO REDUCE THE RISK OF FIRE, ELECTRIC SHOCK
AND PERSONAL INJURY, INCLUDING THE FOLLOWING.**

PLACING TOOL IN SERVICE

- Use only with Ingersoll–Rand Series Controllers.
- Always operate, inspect and maintain this tool in accordance with all regulations (local, state, federal and country), that may apply to hand held/hand operated electric tools.
- Inspect tool cords periodically and if damaged, have them repaired by an authorized service facility.
- Do not remove any labels. Replace any damaged label.

USING THE TOOL

- Always wear eye protection when operating or performing maintenance on this tool.
- Always wear hearing protection when operating this tool.
- Power tools can vibrate in use. Vibration, repetitive motions, or uncomfortable positions may be harmful to your hands and arms. Stop using any tool if discomfort, tingling feeling or pain occurs.

Seek medical advice before resuming use.

- **Guard Against Electric Shock.** Prevent body contact with earthed or grounded surfaces. For example; pipes, radiators, ranges, refrigerator enclosures.
- **Don't abuse Cord.** Never carry tool by cord or yank it to disconnect from receptacle. Keep cord from heat, oil, and sharp edges.
- **Keep work area clean.** Cluttered areas and benches invite injuries.
- **Consider work area environment.** Don't expose power tools and chargers to water. Keep work area well lighted. Do not use tool in explosive or flammable atmospheres.
- **Keep bystanders and children away.** Do not permit unauthorized personnel to operate this tool, or touch tool or cord.
- **Store idle tools.** When not in use, tools should be stored in a dry, high or locked up place, out of reach of children.

(Continued on page 8–2)

NOTICE

The use of other than genuine Ingersoll–Rand replacement parts may result in safety hazards, decreased tool performance, and increased maintenance, and may invalidate all warranties.

Repairs should be made only by authorized trained personnel. Consult your nearest Ingersoll–Rand Authorized Service center.

Refer All Communications to the Nearest
Ingersoll–Rand Office or Distributor.

© Ingersoll–Rand Company 1999

Printed in U.S.A.

INGERSOLL-RAND®
PROFESSIONAL TOOLS

 **WARNING****FAILURE TO OBSERVE THE FOLLOWING WARNINGS COULD RESULT IN INJURY.****USING THE TOOL (*Continued*)**

- **Don't force tool.** It will do the job better and more safely at the rate for which it was intended.
- **Use the right tool.** Do not force a small tool or attachment to do the job of a heavy-duty tool.
- **Do not use a tool for a purpose for which it is not intended.** Example: Do not use a screwdriver as a drill.
- **Dress properly.** Do not wear loose clothing or jewelry. They can be caught in moving parts. Rubber gloves and non-skid footwear are recommended when working outdoors. Wear protective hair covering to contain long hair.
- **Secure work.** Use clamps or a vise to hold work. Operators often need both hands to perform job functions.
- **Don't overreach.** Keep proper footing, balance, and a firm grip on the tool at all times.
- **Maintain tools with care.** Keep tools clean for better and safer performance. Follow instructions for lubricating and changing accessories. Inspect tool cords periodically and if damaged, have them repaired by an authorized service facility. Inspect extension cords periodically and replace if damaged. Keep handles dry, clean, and free from oil and grease.
- **Remove adjusting keys and wrenches.** Form habit of checking to see that keys and adjusting wrenches are removed from tool before turning it on.
- **Avoid unintentional starting.** Don't carry tool with finger on switch.
- **Do not drop or abuse the tool.**
- **Anticipate and be alert for sudden changes in motion during start up and operation of any power tool.**
- **Whenever a tool is not being used, position the Power Switch to the "OFF" position and unplug the power cord.**
- **Stay alert.** Watch what you are doing. Use common sense. Do not operate tool when you are tired.
- **Check damaged parts.** Before further use of the tool, a guard or other part that is damaged should be carefully checked to determine that it will operate properly and perform its intended function. Check for alignment of moving parts, binding of moving parts, breakage of parts, mounting, and any other conditions that may affect its operation. A guard or other part that is damaged should be properly repaired or replaced by an authorized service center unless otherwise indicated elsewhere in this operation manual.
- **Have defective switches replaced by an authorized service center.**
- **Do not use the tool if the switch does not turn it on and off.**
- **Whenever the Angle Head is installed or repositioned, the Throttle Lever must be positioned so that reaction torque will not tend to retain the throttle in the "ON" position.**
- **When installing or removing the output device on any tool, ALWAYS grasp a metal component of the tool while tightening or loosening the Coupling Nut or Spindle Cap. Acceptable clamping locations include, but are not limited to, the hex on the Gear Case, the Tool Hanger, the Torque Reaction Arm or any metal Mounting Plate. NEVER grasp the composite tool body or handle in vise jaws to restrain the torque of the Coupling Nut or Spindle Cap. Such practice will result in damage to the tool.**
- **Do not use power units and gear trains that exceed the capability of the output device.**
- **The Tube Nut Attachment has an opening on the front side for construction and application purposes. DO NOT, under any circumstance place your fingers in this opening.**
- **The Torque Reaction Bar must be positioned against a positive stop. Do not use the Bar as a dead handle and take all precautions to make certain the operator's hand cannot be pinched between the Bar and a solid object.**
- **When operated continuously for long periods of time, Series D Nutrunners may become hot at the spindle end of the tool. Take all precautions necessary to avoid skin contact with the hot surfaces. Prolonged contact may result in burns.**
- **All Series D Torque Control Wrenches and Nutrunners with reverse capability have rotational arrows molded into the housing in the area of the reversing mechanism. When the direction switching device is positioned nearest the molded circular arrow with an "F" in the center, spindle rotation will be forward or clockwise direction. When the direction switching device is positioned nearest the molded circular arrow with an "R" in the center, spindle rotation will be reverse or counter-clockwise direction.**
- **Use only impact sockets and accessories. Do not use hand (chrome) sockets or accessories.**

WARNING LABEL IDENTIFICATION

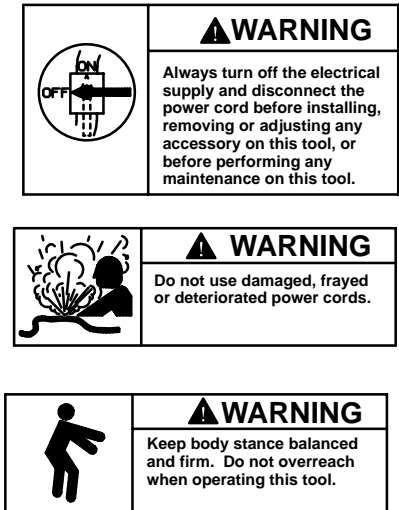

WHEN THIS MODULE IS USED WITH AN AIR POWERED TOOL

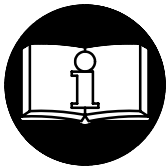

⚠ WARNING

**IMPORTANT SAFETY INFORMATION ENCLOSED.
READ THIS MANUAL BEFORE OPERATING TOOL.**

**IT IS THE RESPONSIBILITY OF THE EMPLOYER TO PLACE THE INFORMATION
IN THIS MANUAL INTO THE HANDS OF THE OPERATOR.**

FAILURE TO OBSERVE THE FOLLOWING WARNINGS COULD RESULT IN INJURY.

PLACING TOOL IN SERVICE

- Always operate, inspect and maintain this tool in accordance with all regulations (local, state, federal and country), that may apply to hand held/hand operated pneumatic tools.
- For safety, top performance, and maximum durability of parts, operate this tool at 90 psig (6.2 bar/620 kPa) maximum air pressure at the inlet with 3/8" (10 mm) inside diameter air supply hose.
- Always turn off the air supply and disconnect the air supply hose before installing, removing or adjusting any accessory on this tool, or before performing any maintenance on this tool.
- Do not use damaged, frayed or deteriorated air hoses and fittings.
- Be sure all hoses and fittings are the correct size and are tightly secured.
- Always use clean, dry air at 90 psig maximum air pressure. Dust, corrosive fumes and/or excessive moisture can ruin the motor of an air tool.
- Do not lubricate tools with flammable or volatile liquids such as kerosene, diesel or jet fuel.
- Do not remove any labels. Replace any damaged label.

USING THE TOOL

- Always wear eye protection when operating or performing maintenance on this tool.
- Always wear hearing protection when operating this tool.
- Keep hands, loose clothing and long hair away from rotating end of tool.
- Note the position of the reversing lever before operating the tool so as to be aware of the direction of rotation when operating the throttle.
- Anticipate and be alert for sudden changes in motion during start up and operation of any power tool.
- Keep body stance balanced and firm. Do not overreach when operating this tool. High reaction torques can occur at or below the recommended air pressure.
- Tool shaft may continue to rotate briefly after throttle is released.
- Air powered tools can vibrate in use. Vibration, repetitive motions or uncomfortable positions may be harmful to your hands and arms. Stop using any tool if discomfort, tingling feeling or pain occurs. Seek medical advice before resuming use.

(Continued on page 8-4)









⚠ WARNING

FAILURE TO OBSERVE THE FOLLOWING WARNINGS COULD RESULT IN INJURY.

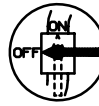
USING THE TOOL (Continued)

- Use accessories recommended by Ingersoll-Rand.
- Use only impact sockets and accessories. Do not use hand (chrome) sockets or accessories.
- This tool is not designed for working in explosive atmospheres.
- This tool is not insulated against electric shock.
- Do not remove the Inlet Plug without first disconnecting the live air supply.
- Whenever the Angle Head is installed or repositioned, the Throttle Lever must be positioned so that reaction torque will not tend to retain the throttle in the “ON” position.
- When installing or removing the output device on any tool, ALWAYS grasp a metal component of the tool while tightening or loosening the Coupling Nut or Spindle Cap. Acceptable clamping locations include, but are not limited to, the hex on the Gear Case, the Tool Hanger, the Torque Reaction Arm or any metal Mounting Plate. NEVER grasp the composite tool body or handle in vise jaws to restrain the torque of the Coupling Nut or Spindle Cap. Such practice will result in damage to the tool.
- Do not use power units and gear trains that exceed the capability of the output device.
- The Tube Nut Attachment has an opening on the front side for construction and application purposes. DO NOT, under any circumstance place your fingers in this opening.
- The Torque Reaction Bar must be positioned against a positive stop. Do not use the Bar as a dead handle and take all precautions to make certain the operator’s hand cannot be pinched between the Bar and a solid object.
- When operated continuously for long periods of time, Series D Nutrunners may become hot at the spindle end of the tool. Take all precautions necessary to avoid skin contact with the hot surfaces. Prolonged contact may result in burns.
- All Series D Torque Control Wrenches and Nutrunners with reverse capability have rotational arrows molded into the housing in the area of the reversing mechanism. When the direction switching device is positioned nearest the molded circular arrow with an “F” in the center, spindle rotation will be forward or clockwise direction. When the direction switching device is positioned nearest the molded circular arrow with an “R” in the center, spindle rotation will be reverse or counter-clockwise direction.

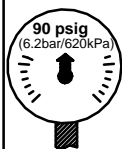
WARNING LABEL IDENTIFICATION

	⚠ WARNING Always wear eye protection when operating or performing maintenance on this tool.		⚠ WARNING Always wear hearing protection when operating this tool.		⚠ WARNING Always turn off the air supply and disconnect the air supply hose before installing, removing or adjusting any accessory on this tool, or before performing any maintenance on this tool.
	⚠ WARNING Air powered tools can vibrate in use. Vibration, repetitive motions or uncomfortable positions may be harmful to your hands and arms. Stop using any tool if discomfort, tingling feeling or pain occurs. Seek medical advice before resuming use.		⚠ WARNING Do not carry the tool by the hose.		⚠ WARNING Do not use damaged, frayed or deteriorated air hoses and fittings.
	⚠ WARNING Keep body stance balanced and firm. Do not overreach when operating this tool.		⚠ WARNING Operate at 90 psig (6.2 bar/ 620 kPa) Maximum air pressure.		⚠ WARNING The Torque Reaction Bar must be positioned against a positive stop. Do not use the Bar as a dead handle and take all precautions to make certain the operator’s hand cannot be pinched between the Bar and a solid object.

D4850-A327 GEARED OFFSET HEAD

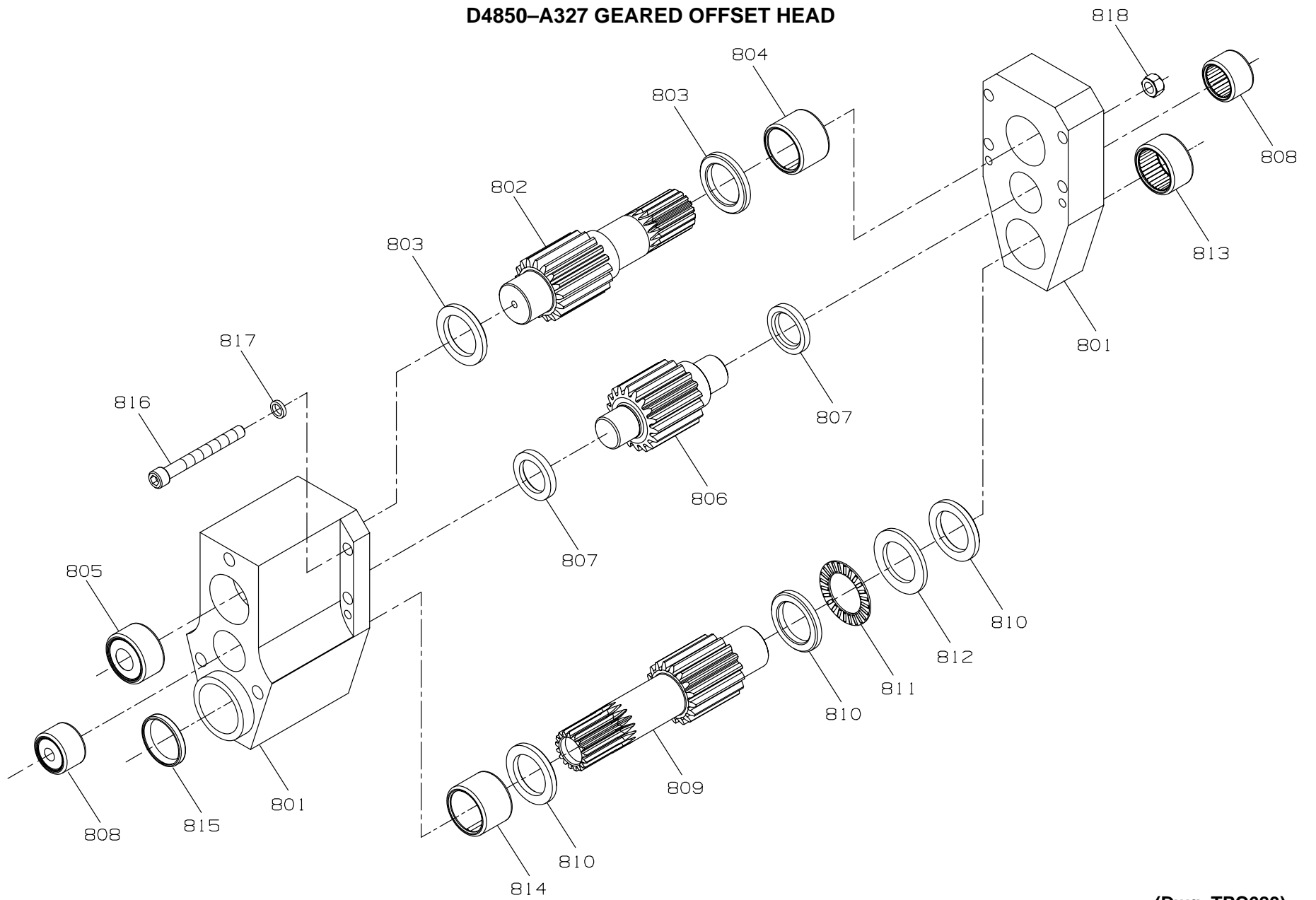

8-5

(Dwg. TPC683)



PART NUMBER FOR ORDERING

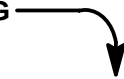

PART NUMBER FOR ORDERING



	Geared Offset Head	D4850-A237	810	Socket Driver Thrust Washer (3)	93952463-A
801	Gear Housing (sold only as a matched set)	D4850-237	811	Socket Driver Thrust Bearing	93952620
802	Drive Gear	D4850-756	812	Bearing Thrust Washer	93952596
803	Drive Gear Thrust Washer (2)	93952463-A	813	Socket Driver Rear Bearing	93952489
804	Drive Gear Rear Bearing	93952604	814	Socket Driver Front Bearing	93952604
805	Drive Gear Front Bearing	93952489	815	Socket Driver Front Bearing Seal	93952612
806	Intermediate Gear	93951747-C	816	Housing Screw (4)	R4860-168
807	Intermediate Gear Thrust Washer (2)	93952638-A	817	Housing Screw Lock Washer (4)	34U-58
808	Intermediate Gear Bearing (2)	R4810-501	818	Housing Screw Nut (4)	D02-428
809	Socket Driver	93951739-C			

MAINTENANCE SECTION

DISASSEMBLY

NOTICE

Do not remove any bearing from the Housings unless you have a new Bearing on hand to replace it. Needle bearings are always damaged during the removal process.

1. Loosen and remove the three screws holding the spindle extension housing to the front of the Gear Housing (801) and the adapter plate.
2. Remove the two screws holding the adapter plate against the Gear Housing.

NOTICE

The four Housing Screw Nuts (818) are only used to hold the assembly together when it is not being used. They are not required for the application.

3. Remove the four Housing Screws (817) and Lock Washers (818) holding the Gear Housing against the gear box. Pull both sections of the gear Housing away from the gear box.

CAUTION

In the following step, some components will be free to fall from the assembly. Place a cardboard box under and near the assembly to catch and protect any parts which might fall.

4. Lightly grasp the large section of the Gear Housing in leather-covered or copper-covered vise jaws and while lightly tapping the Housing with a plastic hammer, carefully separate the two Housing sections.
5. Grasp the shaft of the Drive Gear (802) and pull it, along with the two Drive Gear Thrust Washers (803), out of the Gear Housing.
6. Grasp the shaft of the Intermediate Gear (806) and pull it, along with the two Intermediate Gear Thrust Washers (807), out of the Gear Housing.
7. Pushing on the spline end of the Socket Driver (809), remove the Driver, three Socket Driver Thrust Washers (810), Socket Driver Thrust Bearing (811) and Bearing Thrust Washer (812) from the Gear Housing.
8. Pull the Socket Driver Front Bearing Seal (815) out of the Housing, if the Seal or the Socket Driver Front Bearing (814) must be replaced.
9. To remove the Socket Driver Front Bearing, stand the Gear Housing, socket driver hub upward, on the table of an arbor press and press the Bearing out of the Housing.
10. To remove the Drive Gear Front Bearing (805) and the Intermediate Gear Bearing (808) in that Gear Housing, invert the Housing on the table of the arbor

press. While supporting the bearing face of the Housing and providing clearance for the socket driver hub, press the Bearings out of the Housing.

11. To remove the Socket Driver Rear Bearing (813) and the Intermediate Gear Bearing (808) in that Gear Housing, support the Housing on the arbor press table with the closed ends of the Bearings downward. Press the Bearings from the Housing.
12. Invert the Housing and while supporting it, press the Drive Gear Rear Bearing (804) from the Housing.

ASSEMBLY

NOTICE

Whenever the Geared Offset Head is disassembled for overhaul or replacement of parts, remove all the old grease and pack the Gear Case with Ingersoll-Rand No. 67 Grease.

1. Place the thinner section of the Gear Housing (801) on the table of an arbor press with the hub for the Drive Gear (802) downward.
2. Using a bearing inserting tool as shown in Drawing TPD786, press the Drive Gear Rear Bearing (804) into the Housing until it is flush with the face of the Housing.

NEEDLE BEARING INSERTING TOOL

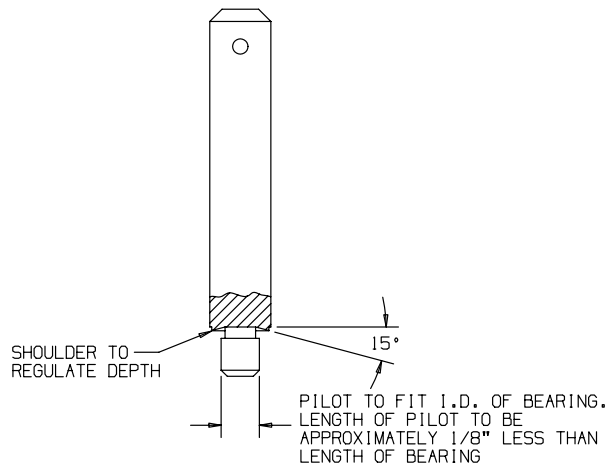

(Dwg. TPD786)

3. Invert that section of the Housing on the arbor press table, and press the one of the Intermediate Gear Bearings (808), closed end trailing, into the center opening of the Housing until it bottoms on the table.
4. Press the Socket Driver Rear Bearing (813), closed end trailing, into the remaining hole in the Housing until it bottoms on the table.
5. Place the thick section of the Gear Housing on the table of an arbor press with the hub for the Socket Driver (809) downward.

MAINTENANCE SECTION

6. Using a bearing inserting tool as shown in Drawing TPD786, press the Socket Driver Front Bearing (814) into the hole in the Housing with the hub until it is flush with the face at the bottom of the Housing.
7. Invert that section of the Housing on the table and support the center opening on a round, metal bar that is larger than the hole with ends that are flat, square and perpendicular.
8. Press the remaining Intermediate Gear Bearing, closed end trailing, into the center opening until it bottoms on the bar and is flush with the inner bottom face of the Housing.
9. Use a similar rod and the same procedure to install the Drive Gear Front Bearing (805) in the remaining hole in the Housing. Make certain the leading edge of the Bearing's open end is flush with the internal housing face.
10. Install a Socket Driver Thrust Washer (810), rounded outer edge leading, onto the long, spline shaft of the Socket Driver.
11. Install another Socket Driver Thrust Washer, rounded edge leading, onto the short hub of the Socket Driver followed by the Socket Driver Thrust Bearing (811), Bearing Thrust Washer (812) and the remaining Socket Driver Thrust Washer, rounded outer edge trailing.
12. Install the assembled Socket Driver in the thick section of the Gear Housing with the spline shaft end protruding through the Housing at the hub.
13. The Intermediate Gear Thrust Washers (807) have a bevel on the edge of the central opening on one side. Install a Washer on each hub of the Intermediate Gear (806) with the bevel side nearest to the gear spline.
14. Align the teeth of the Intermediate Gear with the teeth of the Socket Driver and insert the hub of the assembled Intermediate Gear into the Intermediate Gear Bearing in the Gear Housing.
15. Install a Drive Gear Thrust Washer (803), rounded outer edge leading, onto each hub of the Drive Gear.
16. Align the teeth of the Drive Gear with the teeth of the Intermediate Gear and insert the short hub of the assembled Drive Gear into the Drive Gear Front Bearing in the Gear Housing.
17. There are two pins that align the two sections of the Gear Case. Both may be found in one section of the Gear Case or one in each section. Regardless of their location, bring the sections of the Gear Case together by installing the thin section of the Gear Case over the shaft of the Drive Gear while aligning the pins with the holes and the shafts with the Bearings.
18. Prevent the assembled Gear Case from separating by installing the four Housing Screws (816), Housing Screw Lock Washers (817) and Housing Screw Nuts (818).
19. Being careful not to nick or cut the Seal, install the Socket Driver Front Bearing Seal (815), lip end leading, over the spline shaft of the Socket Driver and into the Gear Case against the Bearing.
20. Rotate the shafts to make sure there is no binding of the gearing and then reinstall the gearing in the application.

NOTICE

SAVE THESE INSTRUCTIONS. DO NOT DESTROY.