

# OPERATION AND MAINTENANCE MANUAL FOR MODELS 45P3 AND 45PQ1 TWIN BLADE IMPULSE WRENCHES

## NOTICE

Models 45P3 and 45PQ1 Impulse Wrenches are designed for use in assembly operations. They are ideally suited to appliance assembly.

Ingersoll-Rand is not responsible for customer modification of tools for applications on which Ingersoll-Rand was not consulted.

## ⚠ WARNING

**IMPORTANT SAFETY INFORMATION ENCLOSED.  
READ THIS MANUAL BEFORE OPERATING TOOL.**

**IT IS THE RESPONSIBILITY OF THE EMPLOYER TO PLACE THE INFORMATION  
IN THIS MANUAL INTO THE HANDS OF THE OPERATOR.**

**FAILURE TO OBSERVE THE FOLLOWING WARNINGS COULD RESULT IN INJURY.**

### PLACING TOOL IN SERVICE

- Always operate, inspect and maintain this tool in accordance with American National Standards Institute Safety Code for Portable Air Tools (ANSI B186.1).
- For safety, top performance, and maximum durability of parts, operate this tool at 90 psig (6.2 bar/620 kPa) maximum air pressure at the inlet with 3/8" (10 mm) inside diameter air supply hose.
- Always turn off the air supply and disconnect the air supply hose before installing, removing or adjusting any accessory on this tool, or before performing any maintenance on this tool.
- Do not use damaged, frayed or deteriorated air hoses and fittings.
- Be sure all hoses and fittings are the correct size and are tightly secured. See Dwg. TPD905-1 for a typical piping arrangement.
- Always use clean, dry air at 90 psig maximum air pressure. Dust, corrosive fumes and/or excessive moisture can ruin the motor of an air tool.
- Do not lubricate tools with flammable or volatile liquids such as kerosene, diesel or jet fuel.
- Do not remove any labels. Replace any damaged label.

- Always wear hearing protection when operating this tool.
- Keep hands, loose clothing and long hair away from rotating end of tool.
- Anticipate and be alert for sudden changes in motion during start up and operation of any power tool.
- Keep body stance balanced and firm. Do not overreach when operating this tool. High reaction torques can occur at or below the recommended air pressure.
- Tool shaft may continue to rotate briefly after throttle is released.
- Air powered tools can vibrate in use. Vibration, repetitive motions or uncomfortable positions may be harmful to your hands and arms. Stop using any tool if discomfort, tingling feeling or pain occurs. Seek medical advice before resuming use.
- Use accessories recommended by Ingersoll-Rand.
- Use only impact sockets and accessories. Do not use hand (chrome) sockets or accessories.
- This tool is not designed for working in explosive atmospheres.
- This tool is not insulated against electric shock.

### USING THE TOOL

- Always wear eye protection when operating or performing maintenance on this tool.

## NOTICE

The use of other than genuine Ingersoll-Rand replacement parts may result in safety hazards, decreased tool performance, and increased maintenance, and may invalidate all warranties.

Repairs should be made only by authorized trained personnel. Consult your nearest Ingersoll-Rand Authorized Servicenter.

Refer All Communications to the Nearest  
Ingersoll-Rand Office or Distributor.

© Ingersoll-Rand Company 2000

Printed in U.S.A.

**INGERSOLL-RAND®**  
**PROFESSIONAL TOOLS**

# WARNING LABEL IDENTIFICATION



FAILURE TO OBSERVE THE FOLLOWING WARNINGS COULD RESULT IN INJURY.

	<b>⚠ WARNING</b>
	Always wear eye protection when operating or performing maintenance on this tool.

	<b>⚠ WARNING</b>
	Always wear hearing protection when operating this tool.

	<b>⚠ WARNING</b>
	Always turn off the air supply and disconnect the air supply hose before installing, removing or adjusting any accessory on this tool, or before performing any maintenance on this tool.

	<b>⚠ WARNING</b>
	Air powered tools can vibrate in use. Vibration, repetitive motions or uncomfortable positions may be harmful to your hands and arms. Stop using any tool if discomfort, tingling feeling or pain occurs. Seek medical advice before resuming use.

	<b>⚠ WARNING</b>
	Do not carry the tool by the hose.

	<b>⚠ WARNING</b>
	Do not use damaged, frayed or deteriorated air hoses and fittings.

	<b>⚠ WARNING</b>
	Keep body stance balanced and firm. Do not overreach when operating this tool.

	<b>⚠ WARNING</b>
	Operate at 90 psig (6.2 bar/ 620 kPa) Maximum air pressure.

## ADJUSTMENTS

### TORQUE ADJUSTMENT

To adjust the torque on these Twin Blade Impulse Wrenches, proceed as follows:

1. Remove the Adjustment Hole Plug.
2. Rotate the Drive Shaft until the Torque Adjustment Screw is visible in the opening.

3. Using a 1.5 mm hex wrench, rotate the Adjustment Screw clockwise to increase the torque output and counterclockwise to decrease the torque output. Do not rotate the Oil Plug.

### NOTICE

**Make all final adjustments at the job.**

4. Replace the Adjustment Hole Plug.

## PLACING TOOL IN SERVICE

### LUBRICATION



Ingersoll-Rand No. 50

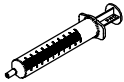

Ingersoll-Rand No. 67

Ingersoll-Rand Fluid Part No. EQ106S-400-1

Always use an air line lubricator with these tools. We recommend the following Filter-Lubricator-Regulator Unit:

**For USA – No. C18-03-FKG0-28**

After each 20 000 cycles, or as experience indicates, drain and refill the Impulse Unit Drive Assembly as instructed in this manual using the Fluid Replacement Kit (Part No. EQ106S-K400). Lubricate the hex drive and the output shaft before assembly.

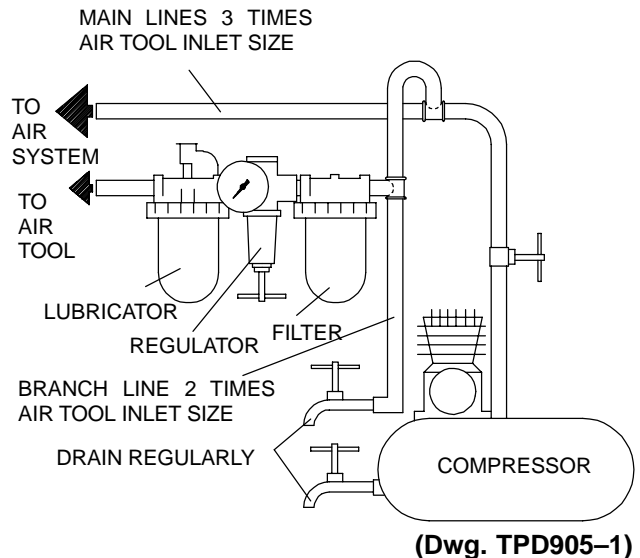

## PLACING TOOL IN SERVICE

### SPECIFICATIONS

Model	Type of Handle	Chuck/Drive in.	Free Speed rpm	Recommended Torque Range	
				Soft Draw ft-lb (Nm)	Hard Slam ft-lb (Nm)
45PQ1	pistol	1/4" insert bit	8,000	10.3–21.4 (14–29)	9.6–20.6 (13–28)
45P3	pistol	3/8" square dr.	8,000	12–23.6 (16–32)	10.3–22 (14–30)

# MANUEL D'EXPLOITATION ET D'ENTRETIEN DES CLÉS F HYDRO-PNEUMATIQUES À DOUBLE PALETTE MODELES 45P3 ET 45PQ1

## NOTE

Les clés hydropneumatiques Modèles 45P3 et 45PQ1 sont destinées aux opérations d'assemblage et conviennent tout particulièrement à l'assemblage des appareillages.

Ingersoll-Rand ne peut être tenu responsable de la modification des outils par le client pour les adapter à des applications qui n'ont pas été approuvées par Ingersoll-Rand.

## ⚠ ATTENTION

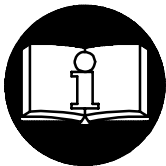

**D'IMPORTANTES INFORMATIONS DE SECURITÉ SONT JOINTES.  
LIRE CE MANUEL AVANT D'UTILISER L'OUTIL.  
L'EMPLOYEUR EST TENU DE COMMUNIQUER LES INFORMATIONS  
DE CE MANUEL AUX EMPLOYÉS UTILISANT CET OUTIL.  
LE NON RESPECT DES AVERTISSEMENTS SUIVANTS PEUT CAUSER DES  
BLESSURES.**

### MISE EN SERVICE DE L'OUTIL

- Toujours exploiter, inspecter et entretenir cet outil conformément au Code de sécurité des outils pneumatiques portatifs de l'American National Standards Institute (ANSI B186.1).
- Pour la sécurité, les performances optimales et la durabilité maximale des pièces, cet outil doit être connecté à une alimentation d'air comprimé de 6,2 bar (620 kPa) maximum à l'entrée, avec un flexible de 10 mm de diamètre intérieur.
- Couper toujours l'alimentation d'air comprimé et débrancher le flexible d'alimentation avant d'installer, déposer ou ajuster tout accessoire sur cet outil, ou d'entreprendre une opération d'entretien quelconque sur l'outil.
- Ne pas utiliser des flexibles ou des raccords endommagés, effilochés ou détériorés.
- S'assurer que tous les flexibles et les raccords sont correctement dimensionnés et bien serrés. Voir Plan TPD905-1 pour un exemple type d'agencement des tuyauteries.
- Utiliser toujours de l'air sec et propre à une pression maximum de 6,2 bar. La poussière, les fumées corrosives et/ou une humidité excessive peuvent endommager le moteur d'un outil pneumatique.
- Ne jamais lubrifier les outils avec des liquides inflammables ou volatils tels que le kérosène, le gasol ou le carburant d'aviation.
- Ne retirer aucune étiquette. Remplacer toute étiquette endommagée.

### UTILISATION DE L'OUTIL

- Porter toujours des lunettes de protection pendant l'utilisation et l'entretien de cet outil.

## NOTE

L'utilisation de rechanges autres que les pièces d'origine Ingersoll-Rand peut causer des risques d'insécurité, réduire les performances de l'outil et augmenter l'entretien, et peut annuler toutes les garanties.

Les réparations ne doivent être effectuées que par des réparateurs qualifiés autorisés. Consultez votre Centre de Service Ingersoll-Rand le plus proche.

Adressez toutes vos communications au Bureau Ingersoll-Rand ou distributeur le plus proche.

© Ingersoll-Rand Company 2000

Imprimé aux É.U.

**INGERSOLL-RAND®**  
**PROFESSIONAL TOOLS**

# SIGNIFICATION DES ÉTIQUETTES D'AVERTISSEMENT

## ATTENTION

LE NON RESPECT DES AVERTISSEMENTS SUIVANTS PEUT CAUSER DES BLESSURES

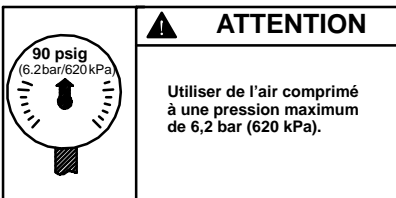
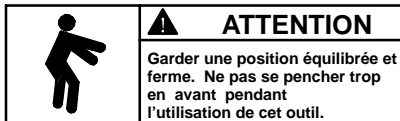
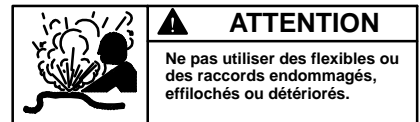
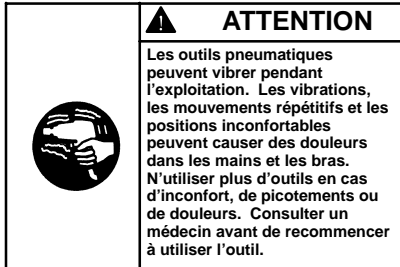
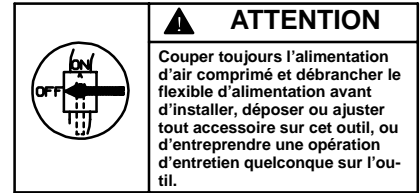
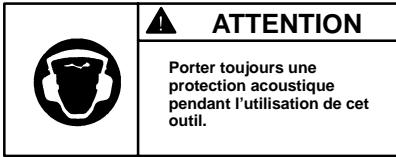
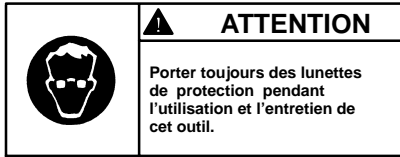

## MISE EN SERVICE DE L'OUTIL

### RÉGLAGE DU COUPLE

Pour ajuster le couple sur ces clés à impulsion bi-lame, procéder comme suit:

1. Retirer le bouchon du trou de réglage.
2. Tourner l'arbre d'entraînement jusqu'à ce que la vis de réglage de couple soit visible dans l'ouverture.
3. A l'aide d'une clé pour six pans creux de 1,5 mm, tourner la vis dans le sens des aiguilles d'une montre pour augmenter le couple de serrage, ou dans le sens inverse des aiguilles d'une montre pour réduire le couple. Ne pas tourner le bouchon d'huile.

### NOTE

Effectuer tous les réglages finaux sur l'écrou à serrer.

4. Remonter le bouchon dans le trou de réglage.

### LUBRIFICATION



Ingersoll-Rand No. 50



Ingersoll-Rand No. 67

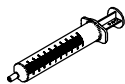

Fluide Ingersoll-Rand  
Réf. No. EQ106S-400-1

Utiliser toujours un lubrificateur avec ces outils. Nous recommandons l'emploi du filtre-régulateur-lubrificateur suivant :

É.U. – No. C18-03-FKG0-28

Tous les 20.000 cycles, ou en fonction de l'expérience, vider et remplir l'ensemble de mécanisme d'impulsion conformément aux instructions du manuel en utilisant le nécessaire de fluide de remplacement (Réf. No. EQ106S-K400). Lubrifier l'entraîneur hexagonal et l'arbre de sortie avant l'assemblage

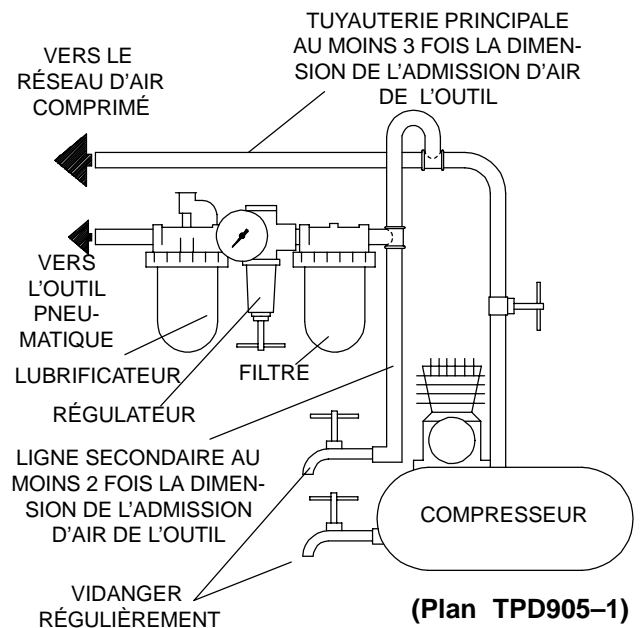

## MISE EN SERVICE DE L'OUTIL

### SPÉCIFICATIONS

Modèle	Poignée à levier	Limiteur/ Entraînement	Vitesse libre	Gamme de couples recommandée	
				Serrage élastique ft-lb (Nm)	Serrage fort ft-lb (Nm)
		pouces	tr/mn		
45PQ1	pistolet	embout 1/4"	8.000	10,3–21,4 (14–29)	9,6–20,6 (13–28)
45P3	pistolet	3/8" entr. carré	8.000	12–23,6 (16–32)	10,3–22 (14–30)

# MANUAL DE USO Y MANTENIMIENTO PARA LLAVES DE IMPULSO DE DOBLE PALETA MODELOS 45P3 Y 45PQ1

E

## NOTA

Las Llaves de Impulso Modelos 45P3 y 45PQ1 están diseñadas para operaciones de montaje y resultan especialmente eficaces en el montaje de electrodomésticos.

Ingersoll–Rand no aceptará responsabilidad alguna por la modificación de las herramientas efectuada por el cliente para las aplicaciones que no hayan sido consultadas con Ingersoll–Rand.

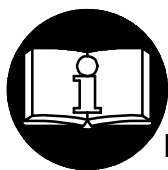

## ⚠ AVISO

**SE ADJUNTA INFORMACIÓN IMPORTANTE DE SEGURIDAD.  
LEA ESTE MANUAL ANTES DE USAR LA HERRAMIENTA.  
ES RESPONSABILIDAD DE LA EMPRESA ASEGURARSE DE QUE EL OPERARIO  
ESTÉ AL TANTO DE LA INFORMACIÓN QUE CONTIENE ESTE MANUAL.  
EL HACER CASO OMISO DE LOS AVISOS SIGUIENTES PODRÍA OCASIONAR  
LESIONES.**

### PARA PONER LA HERRAMIENTA EN SERVICIO

- Utilice, examine y mantenga siempre esta herramienta conforme al código de seguridad para herramientas neumáticas portátiles de la American National Standards Institute (ANSI B186.1).
- Para seguridad, máximo rendimiento y vida de servicio de las piezas, use esta herramienta a una presión de aire máxima de 90 psig (6,2 bar/620 kPa) en la manguera de suministro de aire con diámetro interno de 10 mm.
- Corte siempre el suministro de aire y desconecte la manguera de suministro de aire antes de instalar, desmontar o ajustar cualquier accesorio de esta herramienta, o antes de realizar cualquier operación de mantenimiento de la misma.
- No utilice mangueras de aire y accesorios dañados, desgastados ni deteriorados.
- Asegúrese de que todas las mangueras y accesorios sean del tamaño correcto y estén bien apretados. Vea Esq. TPD905–1 para un típico arreglo de tuberías.
- Use siempre aire limpio y seco a una presión máxima de 90 psig. El polvo, los gases corrosivos y/o el exceso de humedad podrían estropear el motor de una herramienta neumática.
- No lubrique las herramientas con líquidos inflamables o volátiles tales como queroseno, gasoil o combustible para motores a reacción.
- No saque ninguna etiqueta. Sustituya toda etiqueta dañada.

### USO DE LA HERRAMIENTA

- Use siempre protección ocular cuando utilice esta herramienta o realice operaciones de mantenimiento en la misma.

- Use siempre protección para los oídos cuando utilice esta herramienta.
- Mantenga las manos, la ropa suelta y el cabello largo alejados del extremo giratorio de la herramienta.
- Anticipe y esté alerta sobre los cambios repentinos en el movimiento durante la puesta en marcha y el manejo de toda herramienta motorizada.
- Mantenga una postura de cuerpo equilibrada y firme. No estire demasiado los brazos al manejar la herramienta. Pueden ocurrir reacciones de alto par a, o a menos de, la recomendada presión de aire.
- El eje de la herramienta podría seguir girando brevemente después de haber soltado la palanca de estrangulación.
- Las herramientas neumáticas pueden vibrar durante el uso. La vibración, repetición o posiciones incómodas pueden dañarle los brazos y manos. En caso de incomodidad, sensación de hormigueo o dolor, deje de usar la herramienta. Consulte a un médico antes de volver a usarla otra vez.
- Utilice únicamente los accesorios Ingersoll–Rand recomendados.
- Utilice únicamente bocas y accesorios para llaves de impacto. No utilice bocas o accesorios manuales (cromados).
- Esta herramienta no ha sido diseñada para trabajar en ambientes explosivos.
- Esta herramienta no está aislada contra descargas eléctricas.

## NOTA

El uso de piezas de recambio que no sean las auténticas piezas Ingersoll–Rand podría poner en peligro la seguridad, reducir el rendimiento de la herramienta y aumentar los cuidados de mantenimiento necesarios, así como invalidar toda garantía.

Las reparaciones sólo serán realizadas por personal cualificado y autorizado. Consulte con el centro de servicio Ingersoll–Rand autorizado más próximo.

Toda comunicación se deberá dirigir a la oficina o al distribuidor Ingersoll–Rand más próximo.

© Ingersoll–Rand Company 2000

Impreso en EE. UU.

**INGERSOLL-RAND®**  
**PROFESSIONAL TOOLS**

## ETIQUETAS DE AVISO

**⚠ AVISO**

**EL HACER CASO OMISO DE LOS AVISOS SIGUIENTES PODRÍA OCASIONAR LESIONES.**

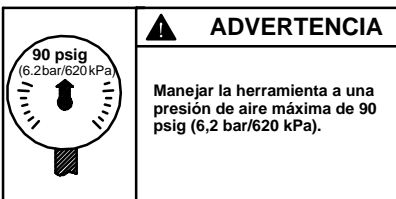
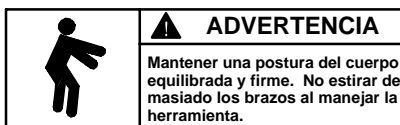
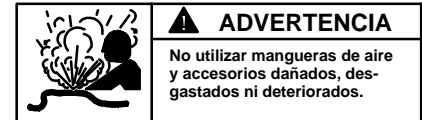
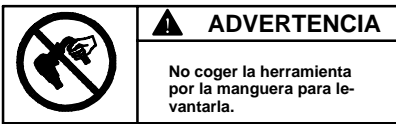
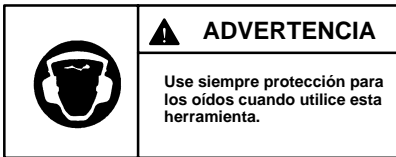
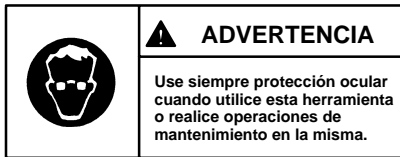

## PARA PONER LA HERRAMIENTA EN SERVICIO

### AJUSTE DE PAR

Para ajustar el par de estas Llaves de Impulso de Doble Paleta, proceda como sigue:

1. Saque el Tapón de Orificio de Ajuste.
2. Gire el Eje de Accionamiento hasta que el tornillo de ajuste de par sea visible a través de dicho orificio.
3. Con una llave hexagonal de 1,5 mm, gire el Tornillo de Ajuste de Par a la derecha para incrementar el par y a la izquierda para disminuirlo. No gire el Tapón de Aceite.

### NOTA

Haga todos los ajustes finales trabajando.

4. Vuelva a poner en su sitio el Tapón de Orificio de Ajuste.

### LUBRICACIÓN



Ingersoll-Rand N° 50

Ingersoll-Rand N° 67



Pieza de fluido  
Ingersoll-Rand  
N°. EQ106S-400-1

Utilice siempre un lubricador de aire comprimido con estas herramientas. Recomendamos la siguiente unidad de Filtro-Lubricador-Regulador:

EE.UU.- C18-03-FKG0-28

Después de cada 20.000 ciclos, o como indique la experiencia, drene y vuelva a llenar el Conjunto de Accionamiento de Unidad de Impulso tal y como se indica en este manual, usando el equipo de cambio de fluido (Pieza N° EQ106S-K400). Lubrique el eje de salida y accionamiento hexagonal antes del montaje.

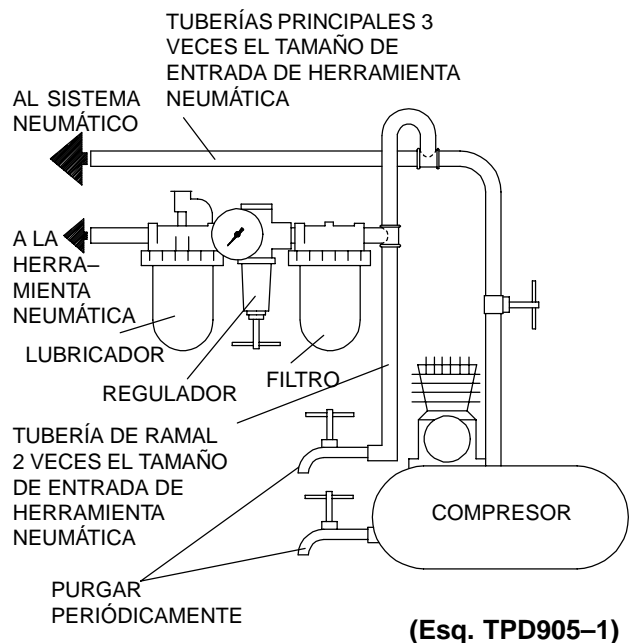



**ESPECIFICACIONES**

<b>Modello</b>	<b>Tipo d'impugnatura</b>	<b>Frizione/ Attacco</b>	<b>Velocità Libra</b>	<b>Gama di coppia consigliata</b>	
				<b>Morbida aspirazione ft-lb (Nm)</b>	<b>Colpo duroe ft-lb (Nm)</b>
45PQ1	impugnatura	poll. punte inserti di 1/4"	giri/min 8.000	10,3-21,4 (14-29)	9,6-20,6 (13-28)
45P3	impugnatura	3/8" att. qd..	8.000	12-23,6 (16-32)	10,3-22 (14-30)

# MANUAL DE FUNCIONAMENTO E MANUTENÇÃO PARA FERRAMENTAS PNEUMÁTICAS DE IMPULSO DE LÂMINAS DUPLAS MODELOS 45P3 E 45PQ1

P

## AVISO

As Chaves de Impulso modelos 45P3 e 45PQ1 são concebidas para operações de montagem e são ideais para a montagem de aparelhos.

A Ingersoll-Rand não é responsável por modificações feitas pelo cliente em ferramentas nas quais a Ingersoll-Rand não tenha sido consultada.

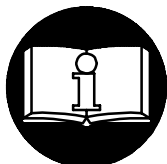

## ⚠️ ADVERTÊNCIA

**INFORMAÇÃO DE SEGURANÇA IMPORTANTE EM ANEXO.  
LEIA ESTE MANUAL ANTES DE OPERAR A FERRAMENTA.  
É DA RESPONSABILIDADE DO EMPREGADOR COLOCAR A INFORMAÇÃO  
DESTE MANUAL NAS MÃOS DO OPERADOR.**

**O NÃO CUMPRIMENTO DAS SEGUINTE ADVERTÊNCIAS PODE RESULTAR EM  
FERIMENTOS.**

### COLOCANDO A FERRAMENTA EM FUNCIONAMENTO

- Sempre opere, inspecione e mantenha esta ferramenta de acordo com o Código de Segurança do Instituto Americano de Padrões Nacionais para Ferramentas Pneumáticas Portáteis (ANSI B186.1).
- Para segurança, máximo desempenho e máxima durabilidade das peças, opere esta ferramenta com uma pressão de ar máxima de 6,2 bar/620 kPa (90 psig) na entrada da mangueira de alimentação de ar com diâmetro interno de 10 mm (3/8").
- Desligue sempre a alimentação de ar e desconecte a mangueira de alimentação de ar antes de instalar, remover ou ajustar qualquer acessório nesta ferramenta, ou antes de executar qualquer serviço de manutenção nesta ferramenta.
- Não use mangueiras de ar ou adaptadores danificados, gastos ou deteriorados.
- Certifique-se de que todas as mangueiras e adaptadores sejam do tamanho correcto e estejam apertados com firmeza. Veja o Desenho TPD905-1 para um arranjo típico de tubagem.
- Use sempre ar seco e limpo com pressão máxima de 90 psig. Pó, fumos corrosivos e/ou humidade excessiva podem arruinar o motor de uma ferramenta pneumática.
- Não lubrifique as ferramentas com líquidos inflamáveis ou voláteis tais como querosene, diesel ou combustível de jactos.
- Não remova nenhum rótulo. Reponha qualquer rótulo danificado.

### USANDO A FERRAMENTA

- Use sempre óculos de protecção quando estiver operando ou executando serviço de manutenção nesta ferramenta.
- Use sempre protecção contra ruído ao operar esta ferramenta.
- Mantenha as mãos, partes do vestuário soltas e cabelos compridos afastados da extremidade em rotação.
- Antecipe e esteja alerta a mudanças repentinas no movimento quando ligar e operar qualquer ferramenta motorizada.
- Mantenha a posição do corpo equilibrada e firme. Não exagere quando operar esta ferramenta. Torques de reacção elevados podem ocorrer na ou abaixo da pressão de ar recomendada.
- O eixo da ferramenta pode continuar a girar brevemente após a pressão ter sido aliviada.
- Ferramentas accionadas pneumáticamente podem vibrar em uso. Vibração, movimentos repetitivos ou posições desconfortáveis podem ser prejudiciais às mãos e aos braços. Pare de usar a ferramenta caso ocorra algum desconforto, sensação de formigueiro ou dor. Procure assistência médica antes de retornar ao trabalho.
- Use acessórios recomendados pela Ingersoll-Rand.
- Use somente soquetes e acessórios de impacto. Não use soquetes ou acessórios de mão (cromo).
- Esta Ferramenta não foi concebida para trabalhos em atmosferas explosivas.
- Esta Ferramenta não está isolada contra choques eléctricos.

## AVISO

O uso de peças de substituição que não sejam genuinamente da Ingersoll-Rand podem resultar em riscos de segurança, diminuição do desempenho da ferramenta, aumento da necessidade de manutenção e pode invalidar todas as garantias.

As reparações devem ser feitas somente por pessoal treinado autorizado. Consulte o Centro de Serviços da Ingersoll-Rand mais próximo.

Envie toda a correspondência ao Escritório ou Distribuidor Ingersoll-Rand mais próximo

© Ingersoll-Rand Company 2000

Impresso nos E.U.A.

**INGERSOLL-RAND®**  
**PROFESSIONAL TOOLS**

# IDENTIFICAÇÃO DO RÓTULO DE ADVERTÊNCIA

## ▲ ADVERTÊNCIA

O NÃO CUMPRIMENTO DAS SEGUINTE ADVERTÊNCIAS PODE RESULTAR EM FERIMENTOS.



**▲ ADVERTÊNCIA**  
Use sempre óculos de proteção quando estiver operando ou executando algum serviço de manutenção nesta ferramenta.



**▲ ADVERTÊNCIA**  
Use sempre proteção contra o ruído ao operar esta ferramenta.



**▲ ADVERTÊNCIA**  
Desligue sempre a alimentação de ar e desconecte a mangueira de alimentação de ar antes de instalar, remover ou ajustar qualquer acessório nesta ferramenta, ou antes de executar algum serviço de manutenção nesta ferramenta.



**▲ ADVERTÊNCIA**  
Ferramentas accionadas pneumáticamente podem vibrar em uso. Vibração, movimentos repetitivos ou posições desconfortáveis podem ser prejudiciais às mãos e aos braços. Pare de usar a ferramenta caso ocorra algum desconforto, sensação de formigamento ou dor. Procure assistência médica antes de retornar ao trabalho.



**▲ ADVERTÊNCIA**  
Não carregue a ferramenta segurando na mangueira.



**▲ ADVERTÊNCIA**  
Não use mangueiras de ar ou adaptadores danificados, gastos ou deteriorados.



**▲ ADVERTÊNCIA**  
Mantenha a posição do corpo equilibrada e firme. Não exagere quando operar esta ferramenta. Torques de reação elevados podem ocorrer sob a pressão de ar recomendada.



**▲ ADVERTÊNCIA**  
Opere com pressão do ar Máxima de 90-100 psig (6,2-6,9 bar).

## COLOCANDO A FERRAMENTA EM FUNCIONAMENTO

### AJUSTE DE TORQUE

Para ajustar o torque nestas Chaves Dinamométricas de Impulsão de Lâminas Duplas, proceda da seguinte maneira:

1. Remova o Bujão do Furo de Ajuste.
2. Gire o Eixo de Comando até o Parafuso de Ajuste de Torque estar visível na abertura.
3. Usando uma chave Allen de 1,5 mm, gire o Parafuso de Ajuste no sentido horário para aumentar o torque de saída e no sentido contrário aos do ponteiros do relógio para diminuir o torque de saída. Não gire o Bujão de Óleo.

### AVISO

Faça todos os ajustes finais no serviço.

4. Reponha o Bujão do Furo de Ajuste.

### LUBRIFICAÇÃO



Ingersoll-Rand No. 50

Ingersoll-Rand No. 67  
Fluído Ingersoll-Rand  
Número de Pedido  
EQ106S-400-1

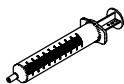

Use sempre um lubrificador de ar de linha com estas ferramentas. Nós recomendamos a seguinte Unidade Filtro-Lubrificador-Regulador:

For E.U.A. – No. C18-03-FKG0-28

Depois de cada 20.000 ciclos, ou como a experiência indicar, drene e encha o Conjunto do Comando da Unidade de Impulso como instruído neste manual usando o Kit de Reposição de Fluído (Número de Pedido EQ106S-K400). Lubrifique o comando hexagonal e o eixo de saída antes de montar.

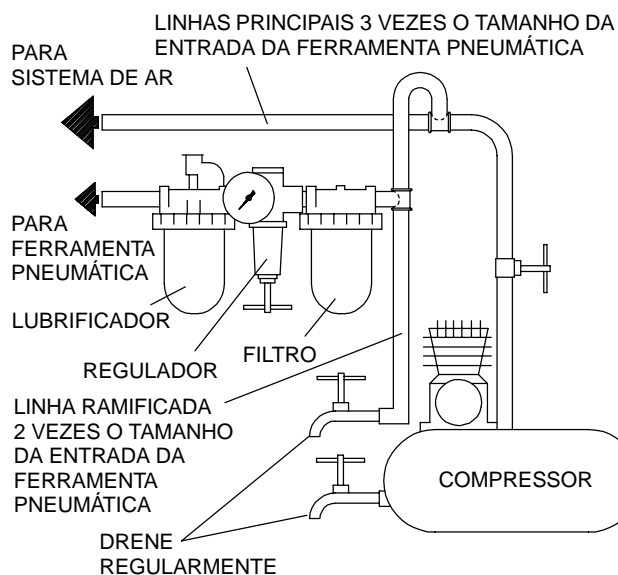

(Desenho TPD905-1)

**ESPECIFICAÇÕES**

<b>Modelo</b>	<b>Tipo de Punho</b>	<b>Encabadouro/ Comando</b>	<b>Velocidade Livre</b>	<b>Intervalo de Torque Recomendado</b>	
				<b>Aperto Ligeiro Nm (pés-lb)</b>	<b>Batimento Duro Nm (pés-lb)</b>
45PQ1	pistola	1/4" bite de inserção	8.000	14-29 (10,3-21,4)	13-28 (9,6-20,6)
45P3	pistola	3/8" quadrada	8.000	16-32 (12-23,6)	14-30 (10,3-22)

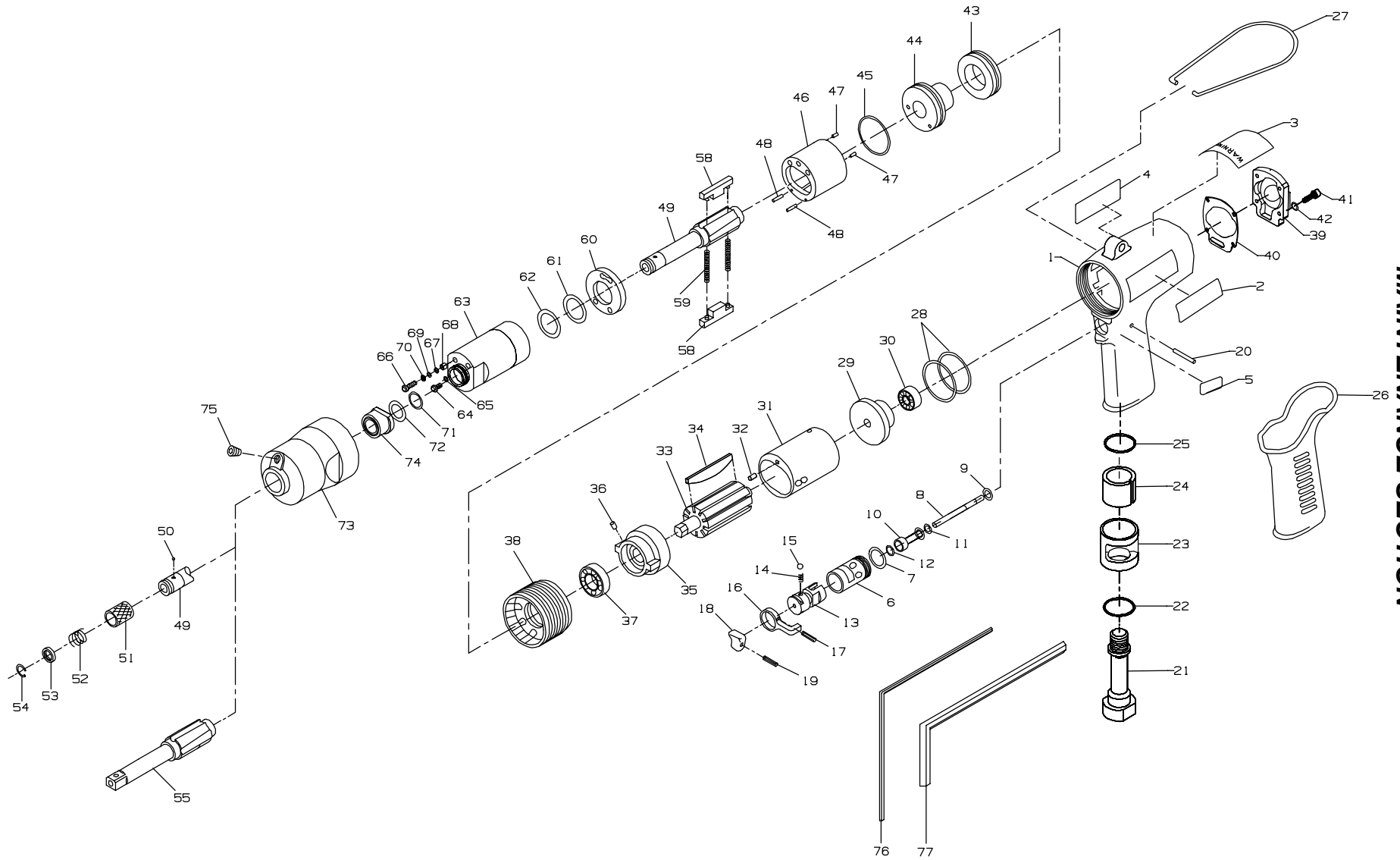

**MAINTENANCE SECTION**



PART NUMBER FOR ORDERING →

PART NUMBER FOR ORDERING →

	Motor Housing Assembly		21	Inlet .....	45P3-980
	for 45P3 .....	45P3-A40	22	O-ring .....	EQ106P-283
	for 45P3-EU .....	45P3-EU-A40	23	Exhaust Deflector .....	45P3-978
	for 45PQ1 .....	45PQ1-A40	24	Exhaust Element .....	45P3-506
	for 45PQ1-EU .....	45PQ1-EU-A40	25	O-ring .....	110PQ-236
1	Motor Housing		26	Boot .....	45P3-2
	for 45P3 .....	45P3-B40	27	Hanger .....	EQ106S-365
	for 45P3-EU .....	45P3-EU-B40	28	Motor Housing O-ring (2) .....	45P3-223
	for 45PQ1 .....	45PQ1-B40		Rear End Plate Assembly .....	45P3-A12
	for 45PQ1-EU .....	45PQ1-EU-B40	29	Rear End Plate .....	45P3-12
2	Information Label .....	55P3-99	30	Rear Rotor Bearing .....	45P3-22
3	Warning Label		31	Cylinder Assembly .....	45P3-A3
	for models ending in -EU .....	EU-99	32	Cylinder Pin .....	45P3-297
	for all other models .....	WARNING-2-99	33	Rotor .....	45P3-53
4	Nameplate		34	Vane Packet (set of 9 Vanes) .....	45P3-42-9
	for 45P3 .....	45P3-301		Front End Plate Assembly .....	45P3-A11
	for 45P3-EU .....	45P3-EU-301	35	Front End Plate .....	45P3-11
	for 45PQ1 .....	45PQ1-301	36	Pin .....	45P3-297
	for 45PQ1-EU .....	45PQ1-EU-301	37	Front Rotor Bearing .....	500P-22
5	Rotation Label .....	60P3-99	38	Front End Plate Spacer .....	45P3-10
6	Throttle Bushing Assembly .....	45P3-A503	39	Backcap .....	45P3-202
7	O-ring .....	45P3-288	40	Backcap Gasket .....	45P3-739
8	Throttle Rod Assembly .....	EQ112P-A302	41	Backcap Cap Screw (4) .....	45P3-638
9	Throttle Rod Seal .....	100PQ-288	42	Backcap Cap Screw Lock Washer (4) .....	45P3-58
10	Throttle Rod Bushing .....	45P3-A303	43	Liner Cap .....	45P3-207
11	Seal .....	EQ106S-288	44	Liner Upper Plate Assembly .....	45P3-A212
12	O-ring .....	EQ106P-303	45	Liner O-ring .....	45P3-273
13	Reverse Valve .....	45P3-329	46	Liner Assembly .....	45P3-A203
14	Reverse Lever Detent Spring .....	100PQ-568	47	Liner Pin (2) (short) .192"/4.8mm .....	45P3-298
15	Reverse Lever Detent Ball .....	EQ104S-929	48	Liner Pin (2) (long) .303"/7.7mm .....	45P3-299
16	Reverse Lever .....	100PQ-328			
17	Reverse Lever Pin .....	180SQ-152			
18	Trigger .....	EQ106P-93			
19	Trigger Pin .....	EQ106P-265			
20	Throttle Retaining Pin .....	100PQ-297			

PART NUMBER FOR ORDERING

PART NUMBER FOR ORDERING

	Drive Shaft Assembly (for 45PQ1) . . . . .	45P3-A726	65	Oil Plug O-ring . . . . .	EQ110P-288
49	Drive Shaft . . . . .	45P3-726	66	Torque Adjustment Screw . . . . .	45P3-230
50	Ball . . . . .	EQ104S-929	67	O-ring . . . . .	EQ106P-288
51	Bit Retaining Sleeve . . . . .	EQ104S-930	68	Pin . . . . .	380SQ-272
52	Retaining Sleeve Spring . . . . .	EQ104S-931	69	Back-up Ring . . . . .	45P3-236
53	Spring Seat . . . . .	EQ104S-932	70	Nylon Ring . . . . .	45PQ-272
54	Retaining Ring . . . . .	EQ104S-933	71	Mechanism Cover Retaining Ring . . . . .	45PQ-271
55	Drive Shaft Assembly (for 45P3) . . . . .	45P3-A626	72	Washer . . . . .	45P3-229
58	Blade (2) . . . . .	45P3-220		Hammer Case Assembly . . . . .	45P3-A727
59	Blade Spring (2) . . . . .	45P3-568	73	Hammer Case . . . . .	45P3-727
60	Front Liner Cover . . . . .	45P3-239	74	Hammer Case Bushing . . . . .	45P3-641
61	Drive Shaft Seal . . . . .	45P3-224	75	Adjustment Hole Plug . . . . .	45P3-95
62	Back Ring . . . . .	180PQ-229	76	Wrench . . . . .	55P3-901
63	Mechanism Cover Assembly . . . . .	45P3-A31	77	Wrench . . . . .	04355012
64	Oil Plug . . . . .	180PQ-277	*	Tool Kit . . . . .	45P-199

\* Not illustrated.

## MAINTENANCE SECTION

### CHANGING THE MECHANISM FLUID

To change the Mechanism Fluid in the Impulse Mechanism, proceed as follows:

1. **For Model 45PQ1**, use a pointed probe to push the Spring Seat (53) against the Retaining Sleeve Spring (52). While the Spring is compressed, use another pointed probe or thin blade screwdriver to remove the Retaining Ring (54). Lift the Spring Seat, Spring and Bit Retaining Sleeve (51) off the Drive Shaft (49) and remove the Bit Retaining Ball (50).
2. **For 45P3**, using copper-covered vise jaws, carefully grasp the flats of the Hammer Case (73) with the output end of the Drive Shaft downward. Use a hooked wire to pull the Retaining Pin Spring (57) out of the end of the Drive Shaft (55) and remove the Socket Retaining Pin (56).
3. Using an adjustable wrench, unscrew the the Motor Housing Assembly (1) from the Hammer Case. This is a **left-hand thread**, rotate the Motor Housing **clockwise** to remove it. (Refer to Dwg. TPD1264)

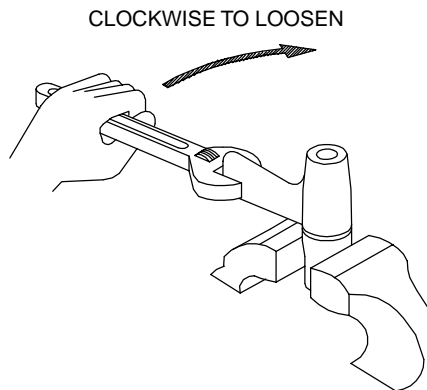

(Dwg. TPD1264)

4. Lift the assembled motor off the Hammer Case and pull the mechanism assembly out of the Cover.
5. Using a 1.5 mm hex wrench, rotate the Torque Adjustment Screw (66) clockwise until the Screw stops. Rotate the Screw counterclockwise until it stops or makes six complete revolutions.
6. Using the special Tee Wrench furnished in the Tool Kit (Part No. 55P-199), remove the Oil Plug (64) and Oil Plug Seal (65).
7. With the oil plug opening downward over a container, rotate the Drive Shaft to purge the fluid from the mechanism. As an alternate method, using the syringe from the Fluid Replacement Kit (Part No. EQ106S-K400), purge the fluid from the first cavity. Then rotate the Drive Shaft to expose the second cavity and purge the fluid using the syringe.

8. Using the syringe and fluid from the Fluid Replacement Kit (Part No. EQ106S-K400), fill the mechanism with the fluid furnished in the Kit. (Refer to Dwg. TPD1265)

#### NOTICE

**DO NOT SUBSTITUTE ANY OTHER FLUID. Failure to use the fluid provided could damage the tool, increase maintenance and decrease performance. Use only clean fluid in these tools.**

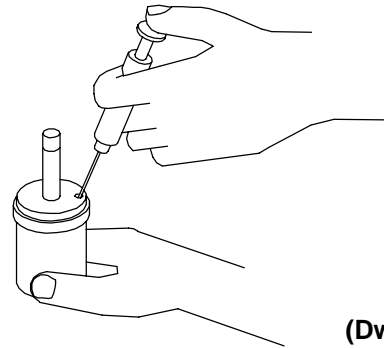

(Dwg. TPD1265)

9. Submerge the fill opening in the remainder of the fluid, and using a wrench, rotate the Drive Shaft to purge any remaining air from the system.
10. Thread the Oil Plug with the Oil Plug Seal into the mechanism until it is snug.
11. Using a 1.5 mm hex wrench, turn the Torque Adjustment Screw clockwise until it stops. This is the maximum torque position.
12. Wipe the outside of the mechanism dry and clean and remove the Oil Chamber Plug. Using the syringe, withdraw .3 cc of fluid.
13. Install the Oil Chamber Plug and tighten it between 20 and 25 in-lb (2.3 and 2.8 Nm) torque.
14. Insert the mechanism assembly, output end leading, into the Mechanism Cover clamped in the vise jaws.
15. Insert the hex end of the rotor shaft into the hex recess at the rear of the Drive Shaft and thread the assembled Motor Housing onto the Mechanism Cover. This is a **left-hand thread**. Rotate the Housing **counterclockwise** to tighten it. (Refer to Dwg. TPD1266)

COUNTERCLOCKWISE TO TIGHTEN

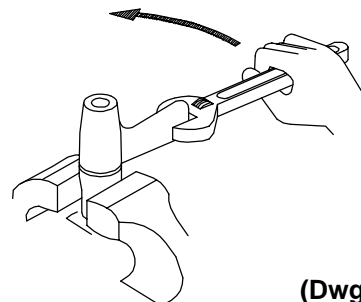

(Dwg. TPD1266)



## MAINTENANCE SECTION

### WARNING

Always wear eye protection when operating or performing maintenance on this tool.

Always turn off the air supply and disconnect the air supply hose before installing, removing or adjusting any accessory on this tool or before performing any maintenance on this tool.

### DISASSEMBLY

#### General Instructions

1. Do not disassemble the tool any further than necessary to replace or repair damaged parts.
2. When grasping a tool or part in a vise, always use leather-covered or copper-covered vise jaws to protect the surface of the part and help prevent distortion. This is particularly true of threaded members and housings.
3. Do not remove any part which is a press fit in or on an assembly unless the removal of that part is necessary for repairs or replacement.
4. Do not disassemble the tool unless you have a complete set of new gaskets and O-rings for replacements.

#### Disassembly of the Impulse Mechanism

1. For Model 45PQ1, use a pointed probe to push the Spring Seat (53) against the Retaining Sleeve Spring (52). While the Spring is compressed, use another pointed probe or thin blade screwdriver to remove the Retaining Ring (54). Lift the Spring Seat, Spring and Bit Retaining Sleeve (51) off the Drive Shaft (49) and remove the Bit Retaining Ball (50).
2. Using copper-covered vise jaws, carefully grasp the flats of the Hammer Case (73) with the output end of the Drive Shaft downward.
3. Using an adjustable wrench, unscrew the Motor Housing Assembly (1) from the Hammer Case. This is a **left-hand thread**, rotate the Motor Housing **clockwise** to remove it. (Refer to Dwg. TPD1264).
4. Lift the assembled motor off the Hammer Case and pull the mechanism assembly out of the Hammer Case. Remove the Washer (72).
5. With the oil plug opening downward over a container, rotate the drive shaft to purge the oil from the mechanism. As an alternate method, using the syringe from

the Fluid Replacement Kit (Part No. EQ106S-K400), purge the fluid from the first cavity. Then rotate the Drive shaft to expose the second cavity and purge the fluid using the syringe.

6. Grasp the flats of the Mechanism Cover Assembly (32) in vise jaws with the output end of the Drive Shaft downward.
7. Insert the pins of the spanner plug from the No. 55P-199 Tool Kit into the two holes in the Liner Cap (43). Using a wrench on the plug, unscrew and remove the Liner Cap from the Mechanism Cover Assembly. (Refer to Dwg. TPD1267)

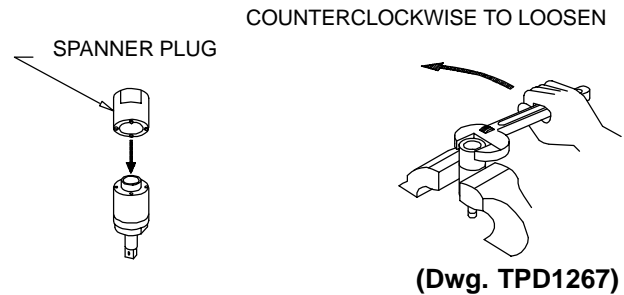

8. Stand the disassembly arbor from the Tool Kit, large end downward, on a workbench or the table of an arbor press. Insert the output end of the Drive Shaft into the central opening and either tap the Housing downward off the components or use the pressing sleeve in the Kit to press the Housing downward off the components. (Refer to Dwg. TPD1268)

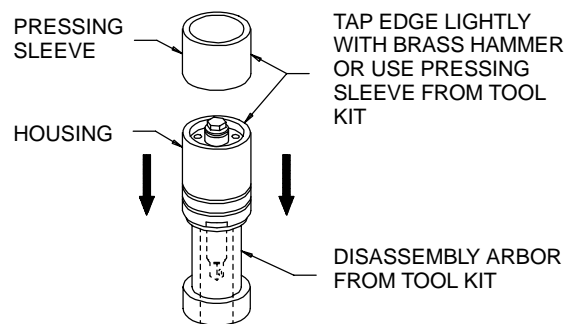

9. Disassemble the components of the mechanism in the sequence shown in Drawing TPA1633 on Page 13.

## MAINTENANCE SECTION

### Disassembly of the Motor

1. Grasp the Motor Housing (1) in vise jaws with the shaft of the Rotor (33) upward.
2. Insert the pins of the end plate spacer spanner into the holes in the Front End Plate Spacer (38). Using a wrench, unscrew and remove the Spacer. This is a **left-hand thread**; rotate the wrench **clockwise** to remove the Spacer. (Refer to Dwg. TPD1269)

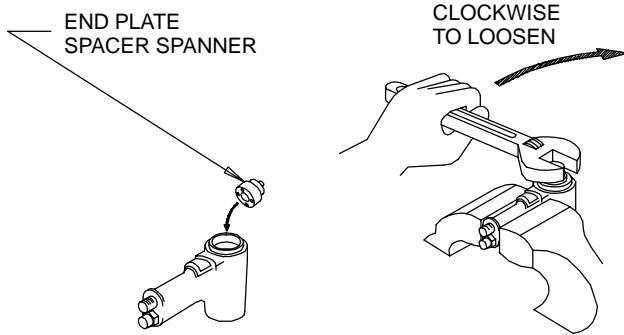

(Dwg. TPD1269)

3. Reposition the Motor Housing in the vise jaws so that the vise jaws grip the end of the rotor shaft and the handle grip of the Housing is downward. Tap the edges of the Housing surrounding the motor bore with a plastic hammer to separate the Housing from the motor. (Refer to Dwg. TPD1270)

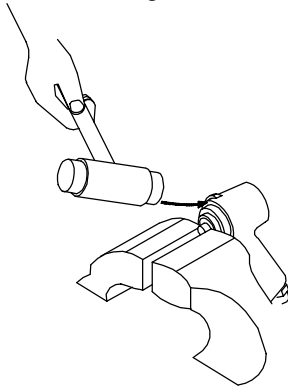

(Dwg. TPD1270)

4. Remove the motor from the vise jaws and remove the Front End Plate (35), Front End Plate Bearing (37), Cylinder Assembly (31) and Vanes (34) from the Rotor.
5. On the table of an arbor press, support the Rear End Plate (29) with blocks as close to the Rotor as possible and press the Rotor out of the Rear End Plate and Rear Rotor Bearing (30).
6. To remove the Rear Rotor Bearing from the Rear End Plate, use a small drift or pin punch through the central opening of the Rear End Plate to tap the Bearing out of the End Plate. (Refer to Dwg. TPD1271)

### NOTICE

**Do not enlarge or damage the shaft hole in the End Plate.**

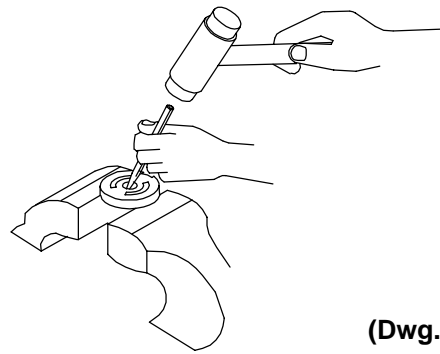

(Dwg. TPD1271)

7. Using a pin punch, tap the Throttle Retaining Pin (20) out of the Handle. The Throttle Retaining Pin is protected by an embossed circular pad of metal. Insert the pin punch into the middle of the pad to locate the Pin. (Refer to Dwg. TPD1272)

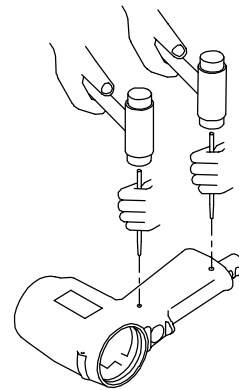

(Dwg. TPD1272)

8. Grasp the Trigger (18) and pull the assembled throttle out of the Motor Housing.
9. Using a pin punch and without damaging the Trigger, remove the Trigger Pin (19).
10. Grasp the Reverse Lever (16) and pull the Reverse Valve (13) from the front of the Throttle Bushing Assembly. The Reverse Lever Detent Ball (15) and Reverse Lever Detent Spring (14) will fall out of the Reverse Valve. Take care not to lose them.
11. Remove the Throttle Rod Assembly (8) from the rear of the Throttle Bushing.
12. Remove the Throttle Rod Seal (9) from the Throttle Rod.
13. If it is necessary to replace the Reverse Lever or Reverse Valve, use a pin punch to tap out the Reverse Lever Pin (17) out of the Reverse Lever. Separate the Reverse Lever from the Reverse Valve.
14. Grasp the Exhaust Deflector Assembly (18) and pull it out of the Housing.
15. Unscrew and remove the Inlet (21).
16. Remove the O-ring (25), Exhaust Deflector (23) with enclosed Exhaust Element (24) and O-ring (22).
17. If Backcap Gasket (40) needs to be replaced, remove Backcap Cap Screws (41), Lockwashers (41) and Backcap (39).

# MAINTENANCE SECTION

## ASSEMBLY

### General Instructions

1. When grasping a tool or part in a vise, always use leather-covered or copper-covered vise jaws to protect the surface of the part and help prevent distortion. This is particularly true of threaded members and housings.
2. Always press on the inner ring of a ball-type bearing when installing the bearing on a shaft.
3. Always press on the outer ring of a ball-type bearing when pressing the bearing into a bearing recess.
4. Except for bearings and mechanism parts, always clean every part and wipe every part with a thin film of oil before installation.
5. Wipe a thin film of mechanism fluid on all internal mechanism components before installing them in the mechanism.
6. Apply a film of o-ring lubricant to every o-ring before installation.

### Assembly of the Motor

1. Install the O-ring (22) on the Inlet (21).
2. Place the Exhaust Element (24) inside the Exhaust Deflector (23) and place the assembled unit on the Inlet.
3. Place the O-ring (25) on the top of the Inlet.
4. Thread the Inlet into the bottom of the handle of the Motor Housing (1) and tighten it between 30 and 35 ft-lb (40 and 47 Nm) torque.
5. Install the Throttle Rod Seal (9) in the groove on the Throttle Rod (8).
6. Put the Reverse Lever (16) on the Reverse Valve (13) and secure it with the Reverse Lever Pin (17).
7. Start the Reverse Valve into the Throttle Bushing (6). Install the Reverse Lever Detent Spring (14) in the hole in the Bushing. Set the Reverse Lever Detent Ball (15) on the Spring and while holding it in place, align the Ball with the detent hole in the Bushing. Push the Valve into the Bushing until the Reverse Lever Detent Ball seats in the detent hole.
8. Insert the Throttle Rod, shaft end first, through the rear of the Throttle bushing and through the Reverse Valve so that the hub of the Throttle Rod seats against the end of the Throttle Bushing.
7. Install the Trigger (18) on the Throttle Rod and secure it with the Trigger Pin (19).

8. Slide the assembled unit into the Motor Housing (1).
9. Install the Throttle Retaining Pin (20) in the Housing, making sure that it captures the Throttle Bushing Assembly.
10. Using an arbor press and a piece of tubing that contacts the outer ring of the bearings, press the Front End Plate Bearing (37) into the Front End Plate (35) and the Rear End Plate Bearing (30) into the Rear End Plate (29). (Refer to Dwg. TPD1274)

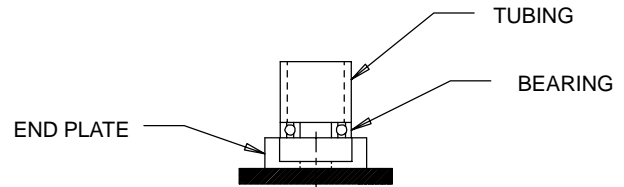

(Dwg. TPD1274)

11. Stand the Rotor (33) on the table of an arbor press. It should be upright on a flat metal plate having a clearance hole for the shaft. The shaft with the hex must be upward.
12. Place a 0.001" (0.025 mm) shim on the upward surface of the large portion of the rotor body. Using a piece of tubing that contacts the inner ring of the bearing, press the Front Rotor Bearing and Front End Plate, End Plate leading, onto the shaft of the Rotor until the End Plate contacts the shim. Remove the shim. (Refer to Dwg. TPD1275)

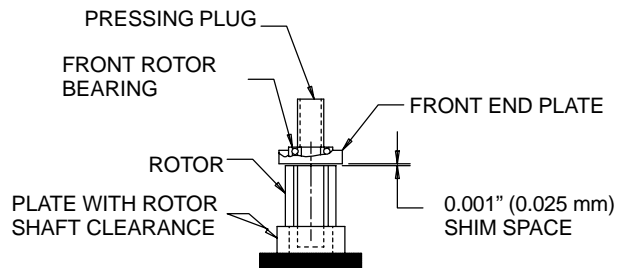

(Dwg. TPD1275)

13. Coat each Vane (34) with a thin film of oil and insert a Vane into each of the rotor vane slots with the straight edge of the Vane outward.

## MAINTENANCE SECTION

14. Install the Cylinder (31) over the Vanes and Rotor with the end of the Cylinder having the Alignment Pin (32) in the middle of the four holes positioned toward the Front End Plate. Make certain the Pin enters the hole in the face of the Front End Plate. (Refer to Dwg. TPD1276).

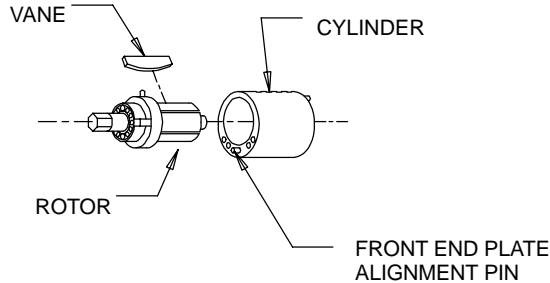

15. Place the Rear End Plate and Bearing against the face of the Cylinder, Bearing end trailing.
16. Insert the assembly into the Motor Housing. It may be necessary to tap the assembly into position with a brass or plastic hammer. (Refer to Dwg. TPD1279)

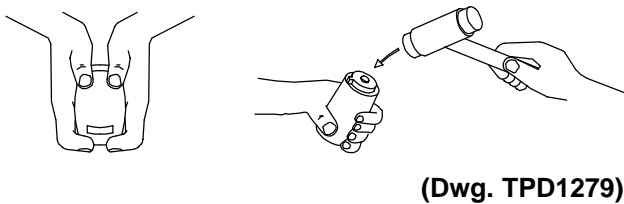

17. Grasp the handle of the Motor Housing in vise jaws with the rotor shaft upward. Thread the Front End Plate Spacer (38) into the Housing and using the end plate spacer spanner, tighten the Spacer to 12 ft-lb (16 Nm) torque. This is a **left-hand thread**; rotate the wrench **counterclockwise** to tighten. (Refer to Dwg. TPD1280).

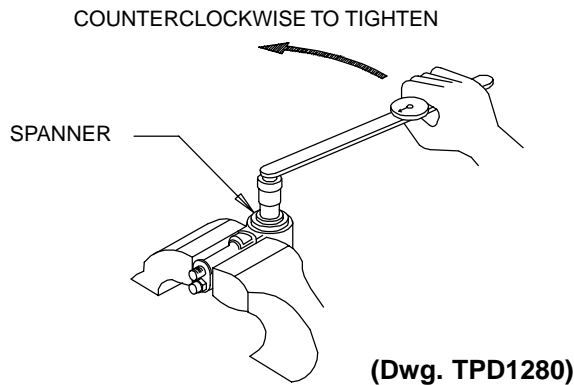

18. After installing the Front End Plate Spacer, grasp the shaft of the Rotor and rotate it by hand. If the Rotor does not turn easily, disassemble the motor unit and determine where the assembly is binding. The motor must rotate freely before proceeding further with the assembly.
19. Place Backcap Gasket (40) on back of Motor Housing. Install Backcap and secure with Backcap Lockwashers (42) and Backcap Cap Screws (41).
20. Install the Boot (26).

### Assembly of the Impulse Mechanism

1. Place a Blade (58) into one of the slots of the Drive Shaft (49 or 55) with the blade assembly pins inward.
2. From the opposite side of the Shaft, encircle each pin with a Blade Spring (59).
3. Install the Assembly Pins of the remaining Blade in the open ends of the Springs. (Refer to Dwg. TPD1283)

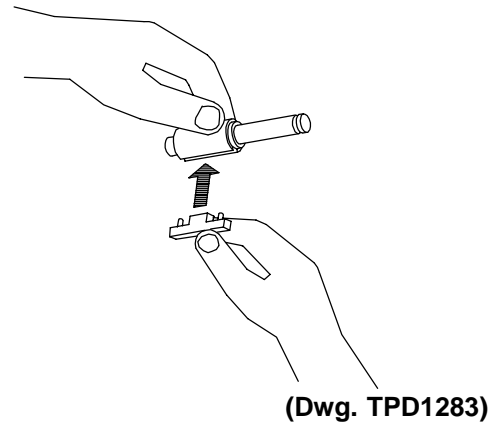

4. Compress the Springs with the Blades until both Blades are flush with the Drive Shaft and install the assembly in the Liner with the output end of the Drive Shaft protruding out the end of the Liner containing the Spring Guide. Make certain the ends of the Blades are flush with the ends of the Liner. (Refer to Dwg. TPD1284).

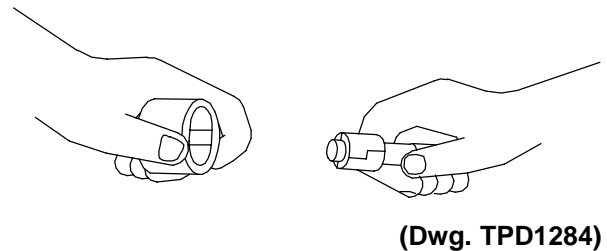

## MAINTENANCE SECTION

5. Install the Drive Shaft Seal (61) followed by the Back Ring (62) on the Drive Shaft against the hub. (Refer to Dwg. TPD1285)

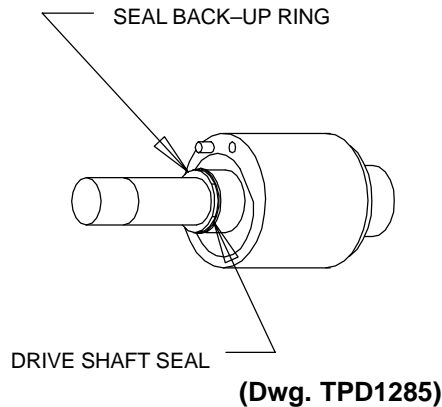

6. The Torque Adjustment Screw (66) can only be installed from the liner end of the Impulse Housing Mechanism Cover Assembly (63). If the Torque Adjustment Screw was removed, proceed as follows:
  - a. Insert a 1.5 mm hex wrench into the threaded hole for the Torque Adjustment Screw from the oil plug end of the Housing.
  - b. From the opposite end of the Housing, install the hex of the Torque Adjustment Screw onto the hex wrench.
  - c. Push the Screw and wrench toward the threaded hole until it contacts the face of the Housing.
  - d. While applying finger pressure to the rivet end of the Screw, rotate the wrench counterclockwise to thread the Screw into the Housing. Continue rotating the Screw until the rivet end stops against the face of the Housing.
7. Align the pin holes in the face of the Rear Liner Cover (44) with the two Liner Pins (47) at the rear of the Liner and place the Cover against the Liner. A groove will be formed between the Liner and Cover for the Rear Liner O-ring (45). Do not attempt to put the Seal in the groove at this time.
8. Align the pin holes in the Front Liner Cover (60) with the Pins in the front face of the Liner and place the Cover against the face of the Liner. Install the Rear Liner Seal in the groove at this time and stand the assembly on the workbench with the output end of the Drive Shaft upward.
9. Lubricate the Rear Liner Seal and after orienting the Housing to the proper position, install the Housing over the Liner.
10. Grasp the flats of the Housing in vise jaws with the output spindle downward. Remove the Rear Liner

Cover Assembly and put grease in the central opening of the Cover. (Refer to Dwg. TPD1289).

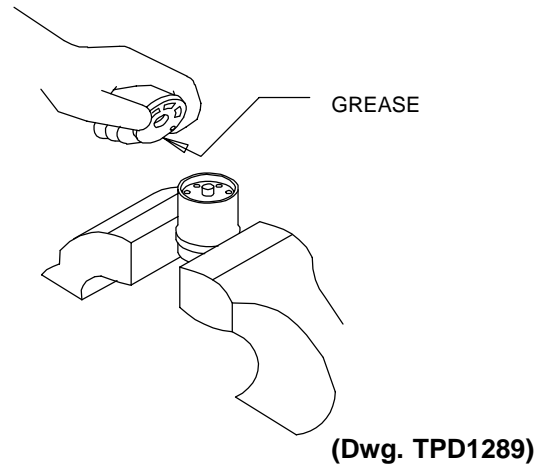

11. Reinstall the Cover Assembly and use a hex wrench to push it below the threads at the rear of the Housing. (Refer to Dwg. TPD1290).

PUSH DOWN

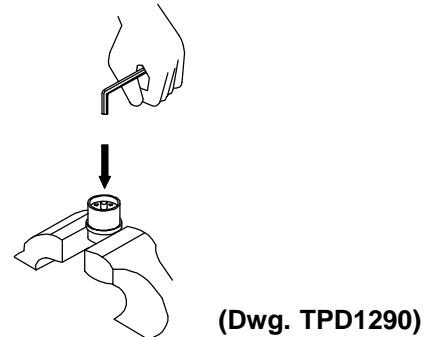

12. Install the Liner Cap (43) and using the spanner plug furnished in the Tool Kit, tighten the Cap between 58–65 ft-lb (78–88 Nm) torque. (Refer to Dwg. TPD1291).

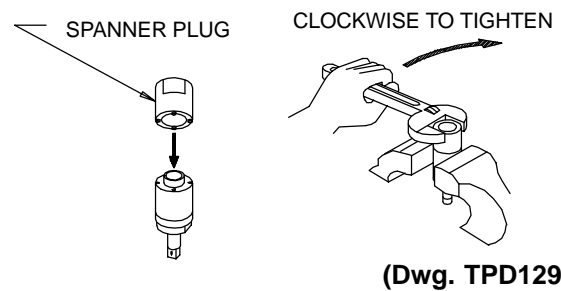

13. Make certain the Drive Shaft rotates freely and then fill the mechanism with fluid and reassemble the tool as instructed in the section, **CHANGING THE MECHANISM FLUID.**