

OPERATION AND MAINTENANCE MANUAL FOR MODEL 70P3 TWIN BLADE IMPULSE WRENCH

NOTICE

Model 70P3 Impulse Wrench is designed for use in assembly operations and is ideally suited to appliance assembly.

Ingersoll-Rand is not responsible for customer modification of tools for applications on which Ingersoll-Rand was not consulted.

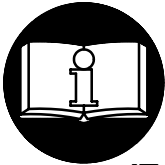

⚠ WARNING

**IMPORTANT SAFETY INFORMATION ENCLOSED.
READ THIS MANUAL BEFORE OPERATING TOOL.**

**IT IS THE RESPONSIBILITY OF THE EMPLOYER TO PLACE THE INFORMATION
IN THIS MANUAL INTO THE HANDS OF THE OPERATOR.
FAILURE TO OBSERVE THE FOLLOWING WARNINGS COULD RESULT IN INJURY.**

PLACING TOOL IN SERVICE

- Always operate, inspect and maintain this tool in accordance with American National Standards Institute Safety Code for Portable Air Tools (ANSI B186.1).
- For safety, top performance, and maximum durability of parts, operate this tool at 90 psig (6.2 bar/620 kPa) maximum air pressure at the inlet with 3/8" (10 mm) inside diameter air supply hose.
- Always turn off the air supply and disconnect the air supply hose before installing, removing or adjusting any accessory on this tool, or before performing any maintenance on this tool.
- Do not use damaged, frayed or deteriorated air hoses and fittings.
- Be sure all hoses and fittings are the correct size and are tightly secured. See Dwg. TPD905-1 for a typical piping arrangement.
- Always use clean, dry air at 90 psig (6.2 bar/620 kPa) maximum air pressure. Dust, corrosive fumes and/or excessive moisture can ruin the motor of an air tool.
- Do not lubricate tools with flammable or volatile liquids such as kerosene, diesel or jet fuel.
- Do not remove any labels. Replace any damaged label.

USING THE TOOL

- Always wear eye protection when operating or performing maintenance on this tool.
- Always wear hearing protection when operating this tool.
- Keep hands, loose clothing and long hair away from rotating end of tool.
- Anticipate and be alert for sudden changes in motion during start up and operation of any power tool.
- Keep body stance balanced and firm. Do not overreach when operating this tool. High reaction torques can occur at or below the recommended air pressure.
- Tool shaft may continue to rotate briefly after throttle is released.
- Air powered tools can vibrate in use. Vibration, repetitive motions or uncomfortable positions may be harmful to your hands and arms. Stop using any tool if discomfort, tingling feeling or pain occurs. Seek medical advice before resuming use.
- Use accessories recommended by Ingersoll-Rand.
- Use only impact sockets and accessories. Do not use hand (chrome) sockets or accessories.
- This tool is not designed for working in explosive atmospheres.
- This tool is not insulated against electric shock.

NOTICE

The use of other than genuine Ingersoll-Rand replacement parts may result in safety hazards, decreased tool performance, and increased maintenance, and may invalidate all warranties.

Repairs should be made only by authorized trained personnel. Consult your nearest Ingersoll-Rand Authorized Servicenter.

Refer All Communications to the Nearest
Ingersoll-Rand Office or Distributor.

© Ingersoll-Rand Company 2000

Printed in U.S.A.

INGERSOLL-RAND®
PROFESSIONAL TOOLS

WARNING LABEL IDENTIFICATION

⚠ WARNING

FAILURE TO OBSERVE THE FOLLOWING WARNINGS COULD RESULT IN INJURY.

	⚠ WARNING
	Always wear eye protection when operating or performing maintenance on this tool.

	⚠ WARNING
	Always wear hearing protection when operating this tool.

	⚠ WARNING
	Always turn off the air supply and disconnect the air supply hose before installing, removing or adjusting any accessory on this tool, or before performing any maintenance on this tool.

	⚠ WARNING
	Air powered tools can vibrate in use. Vibration, repetitive motions or uncomfortable positions may be harmful to your hands and arms. Stop using any tool if discomfort, tingling feeling or pain occurs. Seek medical advice before resuming use.

	⚠ WARNING
	Do not carry the tool by the hose.

	⚠ WARNING
	Do not use damaged, frayed or deteriorated air hoses and fittings.

	⚠ WARNING
	Keep body stance balanced and firm. Do not overreach when operating this tool.

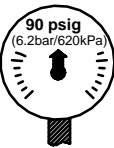
	⚠ WARNING
	Operate at 90 psig (6.2 bar/ 620 kPa) Maximum air pressure.

ADJUSTMENTS

TORQUE ADJUSTMENT

To adjust the torque on these Twin Blade Impulse Wrenches, proceed as follows:

1. Remove the Adjustment Hole Plug.
2. Rotate the Drive Shaft until the Torque Adjustment Screw is visible in the opening.

3. Using a 1.5 mm hex wrench, rotate the Adjustment Screw clockwise to increase the torque output and counterclockwise to decrease the torque output. Do not rotate the Oil Plug.

NOTICE

Make all final adjustments at the job.

4. Replace the Adjustment Hole Plug.

PLACING TOOL IN SERVICE

LUBRICATION



Ingersoll-Rand No. 50

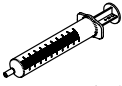

Ingersoll-Rand No. 67

**Ingersoll-Rand Fluid Part
No. EQ106S-400-1**

Always use an air line lubricator with these tools.
We recommend the following Filter-Lubricator-Regulator
Unit:

For USA – No. C18-03-FKG0-28

After each 20 000 cycles, or as experience indicates, drain
and refill the Impulse Unit Drive Assembly as instructed
in this manual using the Fluid Replacement Kit
(Part No. EQ106S-K400). Lubricate the hex drive and the
output shaft before assembly.

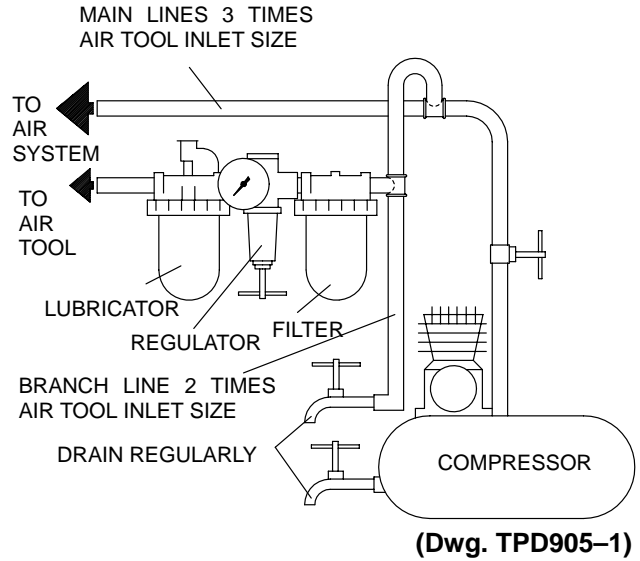

SPECIFICATIONS

Model	Type of Handle	Chuck/Drive in.	Free Speed rpm	Recommended Torque Range	
				Soft Draw ft-lb (Nm)	Hard Slam ft-lb (Nm)
70P3	pistol	3/8" square dr.	7,000	36-56 (50-76)	35-48 (48-65)

MANUEL D'EXPLOITATION ET D'ENTRETIEN DES CLÉS HYDRO-PNEUMATIQUES À DOUBLE PALETTE MODELE 70P3

F

NOTE

La clé hydropneumatique Modèle 70P3 est destinée aux opérations d'assemblage, et est particulièrement adoptée à l'assemblage des appareillages.

Ingersoll-Rand ne peut être tenu responsable de la modification des outils par le client pour les adapter à des applications qui n'ont pas été approuvées par Ingersoll-Rand.

⚠ ATTENTION

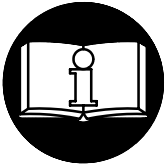

**D'IMPORTANTES INFORMATIONS DE SECURITÉ SONT JOINTES.
LIRE CE MANUEL AVANT D'UTILISER L'OUTIL.
L'EMPLOYEUR EST TENU DE COMMUNIQUER LES INFORMATIONS
DE CE MANUEL AUX EMPLOYÉS UTILISANT CET OUTIL.
LE NON RESPECT DES AVERTISSEMENTS SUIVANTS PEUT CAUSER DES
BLESSURES.**

MISE EN SERVICE DE L'OUTIL

- Toujours exploiter, inspecter et entretenir cet outil conformément au Code de sécurité des outils pneumatiques portatifs de l'American National Standards Institute (ANSI B186.1).
- Pour la sécurité, les performances optimales et la durabilité maximale des pièces, cet outil doit être connecté à une alimentation d'air comprimé de 6,2 bar (620 kPa) maximum à l'entrée, avec un flexible de 10 mm de diamètre intérieur.
- Couper toujours l'alimentation d'air comprimé et débrancher le flexible d'alimentation avant d'installer, déposer ou ajuster tout accessoire sur cet outil, ou d'entreprendre une opération d'entretien quelconque sur l'outil.
- Ne pas utiliser des flexibles ou des raccords endommagés, effilochés ou détériorés.
- S'assurer que tous les flexibles et les raccords sont correctement dimensionnés et bien serrés. Voir Plan TPD905-1 pour un exemple type d'agencement des tuyauteries.
- Utiliser toujours de l'air sec et propre à une pression maximum de 6,2 bar (620 kPa). La poussière, les fumées corrosives et/ou une humidité excessive peuvent endommager le moteur d'un outil pneumatique.
- Ne jamais lubrifier les outils avec des liquides inflammables ou volatils tels que le kérosène, le gasol ou le carburant d'aviation.
- Ne retirer aucune étiquette. Remplacer toute étiquette endommagée.

UTILISATION DE L'OUTIL

- Porter toujours des lunettes de protection pendant l'utilisation et l'entretien de cet outil.

NOTE

L'utilisation de rechanges autres que les pièces d'origine Ingersoll-Rand peut causer des risques d'insécurité, réduire les performances de l'outil et augmenter l'entretien, et peut annuler toutes les garanties.

Les réparations ne doivent être effectuées que par des réparateurs qualifiés autorisés. Consultez votre Centre de Service Ingersoll-Rand le plus proche.

Adressez toutes vos communications au Bureau Ingersoll-Rand ou distributeur le plus proche.

© Ingersoll-Rand Company 2000

Imprimé aux É.U.

INGERSOLL-RAND®
PROFESSIONAL TOOLS

SIGNIFICATION DES ÉTIQUETTES D'AVERTISSEMENT

⚠ ATTENTION

LE NON RESPECT DES AVERTISSEMENTS SUIVANTS PEUT CAUSER DES BLESSURES

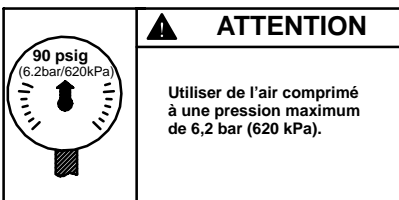
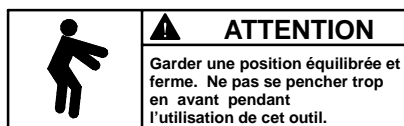
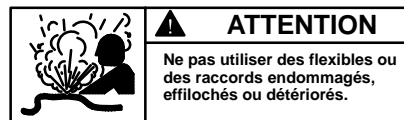
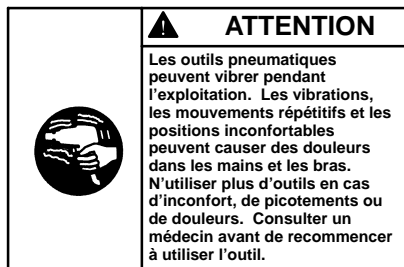
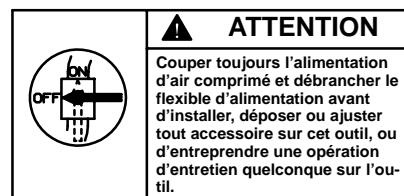
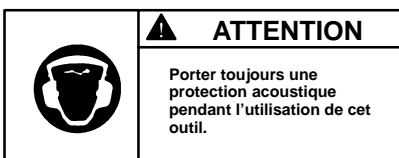
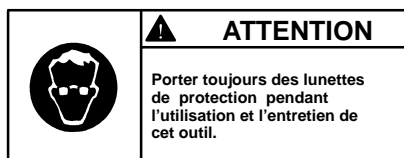

RÉGLAGES

RÉGLAGE DU COUPLE

Pour ajuster le couple sur ces clés à impulsion bi-lame, procéder comme suit:

1. Retirer le bouchon du trou de réglage.
2. Tourner l'arbre d'entraînement jusqu'à ce que la vis de réglage de couple soit visible dans l'ouverture.
3. A l'aide d'une clé pour six pans creux de 1,5 mm, tourner la vis dans le sens des aiguilles d'une montre pour augmenter le couple de serrage, ou dans le sens inverse des aiguilles d'une montre pour réduire le couple. Ne pas tourner le bouchon d'huile.

NOTE

Effectuer tous les réglages finaux sur l'écrou à serrer.

4. Remonter le bouchon dans le trou de réglage.

MISE EN SERVICE DE L'OUTIL

LUBRIFICATION



Ingersoll-Rand No. 50



Ingersoll-Rand No. 67

Fluide Ingersoll-Rand
Réf. No. EQ106S-400-1

Utiliser toujours un lubrificateur avec ces outils. Nous recommandons l'emploi du filtre-régulateur-lubrificateur suivant :

É.U. - No. C18-03-FKG0-28

Tous les 20.000 cycles, ou en fonction de l'expérience, vider et remplir l'ensemble de mécanisme d'impulsion conformément aux instructions du manuel en utilisant le nécessaire de fluide de remplacement (Réf. No. EQ106S-K400). Lubrifier l'entraîneur hexagonal et l'arbre de sortie avant l'assemblage

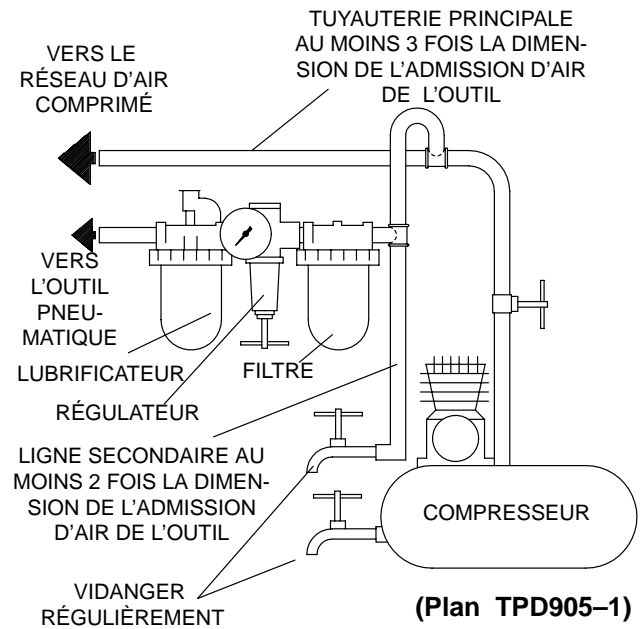

SPÉCIFICATIONS

Modèle	Poignée à levier	Limiteur/ Entraînement	Vitesse libre	Gamme de couples recommandée	
				Serrage élastique Nm	Serrage fort Nm
70P3	pistolet	3/8" entr. carré	7.000	50-76	48-65

MANUAL DE USO Y MANTENIMIENTO PARA LLAVES DE IMPULSO DE DOBLE PALETA MODELO 70P3

E

NOTA

La Llave de Impulso Modelo 70P3 está diseñada para operaciones de montaje y resulta especialmente eficaz en el montaje de electrodomésticos.

Ingersoll-Rand no aceptará responsabilidad alguna por la modificación de las herramientas efectuada por el cliente para las aplicaciones que no hayan sido consultadas con Ingersoll-Rand.

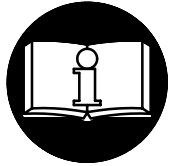

⚠ AVISO

**SE ADJUNTA INFORMACIÓN IMPORTANTE DE SEGURIDAD.
LEA ESTE MANUAL ANTES DE USAR LA HERRAMIENTA.
ES RESPONSABILIDAD DE LA EMPRESA ASEGURARSE DE QUE EL
OPERARIO ESTÉ AL TANTO DE LA INFORMACIÓN QUE CONTIENE ESTE MANUAL.
EL HACER CASO OMISO DE LOS AVISOS SIGUIENTES PODRÍA OCASIONAR
LESIONES.**

PARA PONER LA HERRAMIENTA EN SERVICIO

- Utilice, examine y mantenga siempre esta herramienta conforme al código de seguridad para herramientas neumáticas portátiles de la American National Standards Institute (ANSI B186.1).
- Para seguridad, máximo rendimiento y vida de servicio de las piezas, use esta herramienta a una presión de aire máxima de 90 psig (6,2 bar/620 kPa) en la manguera de suministro de aire con diámetro interno de 10 mm.
- Corte siempre el suministro de aire y desconecte la manguera de suministro de aire antes de instalar, desmontar o ajustar cualquier accesorio de esta herramienta, o antes de realizar cualquier operación de mantenimiento de la misma.
- No utilice mangueras de aire y accesorios dañados, desgastados ni deteriorados.
- Asegúrese de que todas las mangueras y accesorios sean del tamaño correcto y estén bien apretados. Vea Esq. TPD905-1 para un típico arreglo de tuberías.
- Use siempre aire limpio y seco a una presión máxima de 90 psig. El polvo, los gases corrosivos y/o el exceso de humedad podrían estropear el motor de una herramienta neumática.
- No lubrique las herramientas con líquidos inflamables o volátiles tales como queroseno, gasoil o combustible para motores a reacción.
- No saque ninguna etiqueta. Sustituya toda etiqueta dañada.

USO DE LA HERRAMIENTA

- Use siempre protección ocular cuando utilice esta herramienta o realice operaciones de mantenimiento en la misma.
- Use siempre protección para los oídos cuando utilice esta herramienta.
- Mantenga las manos, la ropa suelta y el cabello largo alejados del extremo giratorio de la herramienta.
- Anticipe y esté alerta sobre los cambios repentinos en el movimiento durante la puesta en marcha y el manejo de toda herramienta motorizada.
- Mantenga una postura de cuerpo equilibrada y firme. No estire demasiado los brazos al manejar la herramienta. Pueden ocurrir reacciones de alto par a, o a menos de, la recomendada presión de aire.
- El eje de la herramienta podría seguir girando brevemente después de haber soltado la palanca de estrangulación.
- Las herramientas neumáticas pueden vibrar durante el uso. La vibración, repetición o posiciones incómodas pueden dañarle los brazos y manos. En caso de incomodidad, sensación de hormigueo o dolor, deje de usar la herramienta. Consulte a un médico antes de volver a usarla otra vez.
- Utilice únicamente los accesorios Ingersoll-Rand recomendados.
- Utilice únicamente bocas y accesorios para llaves de impacto. No utilice bocas o accesorios manuales (cromados).
- Esta herramienta no ha sido diseñada para trabajar en ambientes explosivos.
- Esta herramienta no está aislada contra descargas eléctricas.

NOTA

El uso de piezas de recambio que no sean las auténticas piezas Ingersoll-Rand podría poner en peligro la seguridad, reducir el rendimiento de la herramienta y aumentar los cuidados de mantenimiento necesarios, así como invalidar toda garantía.

Las reparaciones sólo serán realizadas por personal cualificado y autorizado. Consulte con el centro de servicio Ingersoll-Rand autorizado más próximo.

Toda comunicación se deberá dirigir a la oficina o al distribuidor Ingersoll-Rand más próximo.

© Ingersoll-Rand Company 2000

Impreso en EE. UU.

INGERSOLL-RAND®
PROFESSIONAL TOOLS

ETIQUETAS DE AVISO

⚠ AVISO

EL HACER CASO OMISO DE LOS AVISOS SIGUIENTES PODRÍA OCASIONAR LESIONES.

	<p>⚠ ADVERTENCIA</p> <p>Use siempre protección ocular cuando utilice esta herramienta o realice operaciones de mantenimiento en la misma.</p>
---	--

	<p>⚠ ADVERTENCIA</p> <p>Use siempre protección para los oídos cuando utilice esta herramienta.</p>
---	---

	<p>⚠ ADVERTENCIA</p> <p>Cortar siempre el suministro de aire y desconectar la manguera de suministro de aire antes de instalar, retirar o ajustar cualquier accesorio de esta herramienta, o antes de realizar cualquier operación de mantenimiento de la misma.</p>
---	---

	<p>⚠ ADVERTENCIA</p> <p>Las herramientas neumáticas pueden vibrar durante el uso. La vibración, los movimientos repetitivos o las posiciones incómodas podrían dañarle los brazos y las manos. En caso de incomodidad, sensación de hormigueo o dolor, dejar de usar la herramienta. Consultar al médico antes de volver a utilizarla.</p>
---	---

	<p>⚠ ADVERTENCIA</p> <p>No coger la herramienta por la manguera para levantarla.</p>
---	---

	<p>⚠ ADVERTENCIA</p> <p>No utilizar mangueras de aire y accesorios dañados, desgastados ni deteriorados.</p>
---	---

	<p>⚠ ADVERTENCIA</p> <p>Mantener una postura del cuerpo equilibrada y firme. No estirar demasiado los brazos al manejar la herramienta.</p>
---	--

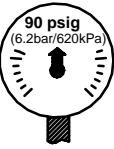
	<p>⚠ ADVERTENCIA</p> <p>Manejar la herramienta a una presión de aire máxima de 90 psig (6,2 bar/620 kPa).</p>
---	--

AJUSTES

AJUSTE DE PAR

Para ajustar el par de estas Llaves de Impulso de Doble Paleta, proceda como sigue:

1. Saque el Tapón de Orificio de Ajuste.
2. Gire el Eje de Accionamiento hasta que el tornillo de ajuste de par sea visible a través de dicho orificio.
3. Con una llave hexagonal de 1,5 mm, gire el Tornillo de Ajuste de Par a la derecha para incrementar el par y a

la izquierda para disminuirlo. No gire el Tapón de Aceite.

NOTA

- Haga todos los ajustes finales trabajando.**
4. Vuelva a poner en su sitio el Tapón de Orificio de Ajuste.

PARA PONER LA HERRAMIENTA EN SERVICIO

LUBRICACIÓN



Ingersoll-Rand N° 50



Ingersoll-Rand N° 67

Pieza de fluido
Ingersoll-Rand
N°. EQ106S-400-1

Utilice siempre un lubricador de aire comprimido con estas herramientas. Recomendamos la siguiente unidad de Filtro-Lubricador-Regulador:

EE. UU. - N°. C18-03-FKG0-28

Después de cada 20.000 ciclos, o como indique la experiencia, drene y vuelva a llenar el Conjunto de Accionamiento de Unidad de Impulso tal y como se indica en este manual, usando el equipo de cambio de fluido (Pieza N° EQ106S-K400). Lubrique el eje de salida y accionamiento hexagonal antes del montaje.

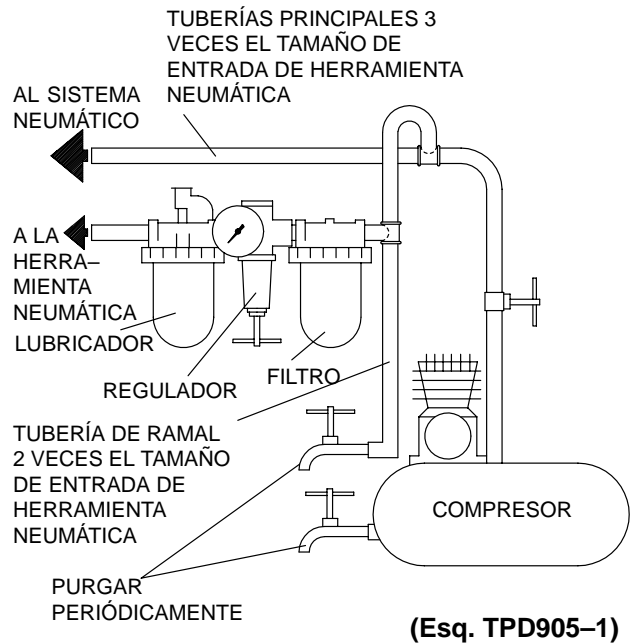

ESPECIFICACIONES

Modelo	Tipo de Empuñadura	Portabroca/Accionamiento	Velocidad Libre	Gama de par recomendada	
				Retroceso Suave ft-lbs (Nm)	Golpe Fuerte ft-lbs (Nm)
		pulg.	rpm		
70P3	pistola	3/8" pulg. broca de inserción	7.000	36-56 (50-76)	35-48 (48-65)

MANUAL DE FUNCIONAMENTO E MANUTENÇÃO PARA FERRAMENTAS PNEUMÁTICAS DE IMPULSO DE LÂMINAS DUPLAS MODELO 70P3

P

AVISO

A Chave de Impulso modelo 70P3 é concebida para operações de montagem e é ideal para a montagem de aparelhos.

A Ingersoll-Rand não é responsável por modificações feitas pelo cliente em ferramentas nas quais a Ingersoll-Rand não tenha sido consultada.

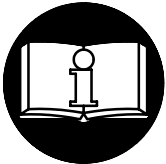

⚠️ ADVERTÊNCIA

**INFORMAÇÃO DE SEGURANÇA IMPORTANTE EM ANEXO.
LEIA ESTE MANUAL ANTES DE OPERAR A FERRAMENTA.
É DA RESPONSABILIDADE DO EMPREGADOR COLOCAR A INFORMAÇÃO
DESTE MANUAL NAS MÃOS DO OPERADOR.**

**O NÃO CUMPRIMENTO DAS SEGUINTE ADVERTÊNCIAS PODE RESULTAR EM
FERIMENTOS.**

COLOCANDO A FERRAMENTA EM FUNCIONAMENTO

- Sempre opere, inspecione e mantenha esta ferramenta de acordo com o Código de Segurança do Instituto Americano de Padrões Nacionais para Ferramentas Pneumáticas Portáteis (ANSI B186.1).
- Para segurança, máximo desempenho e máxima durabilidade das peças, opere esta ferramenta com uma pressão de ar máxima de 6,2 bar/620 kPa (90 psig) na entrada da mangueira de alimentação de ar com diâmetro interno de 10 mm (3/8").
- Desligue sempre a alimentação de ar e desconecte a mangueira de alimentação de ar antes de instalar, remover ou ajustar qualquer acessório nesta ferramenta, ou antes de executar qualquer serviço de manutenção nesta ferramenta.
- Não use mangueiras de ar ou adaptadores danificados, gastos ou deteriorados.
- Certifique-se de que todas as mangueiras e adaptadores sejam do tamanho correcto e estejam apertados com firmeza. Veja o Desenho TPD905-1 para um arranjo típico de tubagem.
- Use sempre ar seco e limpo com pressão máxima de 6,2 bar/620 kPa (90 psig). Pó, fumos corrosivos e/ou humidade excessiva podem arruinar o motor de uma ferramenta pneumática.
- Não lubrifique as ferramentas com líquidos inflamáveis ou voláteis tais como querosene, diesel ou combustível de jactos.
- Não remova nenhum rótulo. Reponha qualquer rótulo danificado.

USANDO A FERRAMENTA

- Use sempre óculos de protecção quando estiver operando ou executando serviço de manutenção nesta ferramenta.
- Use sempre protecção contra ruído ao operar esta ferramenta.
- Mantenha as mãos, partes do vestuário soltas e cabelos compridos afastados da extremidade em rotação.
- Antecipe e esteja alerta a mudanças repentinas no movimento quando ligar e operar qualquer ferramenta motorizada.
- Mantenha a posição do corpo equilibrada e firme. Não exagere quando operar esta ferramenta. Torques de reacção elevados podem ocorrer na ou abaixo da pressão de ar recomendada.
- O eixo da ferramenta pode continuar a girar brevemente após a pressão ter sido aliviada.
- Ferramentas accionadas pneumáticamente podem vibrar em uso. Vibração, movimentos repetitivos ou posições desconfortáveis podem ser prejudiciais às mãos e aos braços. Pare de usar a ferramenta caso ocorra algum desconforto, sensação de formigueiro ou dor. Procure assistência médica antes de retornar ao trabalho.
- Use acessórios recomendados pela Ingersoll-Rand.
- Use somente soquetes e acessórios de impacto. Não use soquetes ou acessórios de mão (cromo).
- Esta Ferramenta não foi concebida para trabalhos em atmosferas explosivas.
- Esta Ferramenta não está isolada contra choques eléctricos.

AVISO

O uso de peças de substituição que não sejam genuinamente da Ingersoll-Rand podem resultar em riscos de segurança, diminuição do desempenho da ferramenta, aumento da necessidade de manutenção e pode invalidar todas as garantias.

As reparações devem ser feitas somente por pessoal treinado autorizado. Consulte o Centro de Serviços da Ingersoll-Rand mais próximo.

Envie Todos os Comunicados Para o Distribuidor ou Escritório da Ingersoll-Rand Mais Próximo.

© Ingersoll-Rand Company 2000

Impresso nos E.U.A.

INGERSOLL-RAND®
PROFESSIONAL TOOLS

IDENTIFICAÇÃO DO RÓTULO DE ADVERTÊNCIA

▲ ADVERTÊNCIA

O NÃO CUMPRIMENTO DAS SEGUINTE ADVERTÊNCIAS PODE RESULTAR EM FERIMENTOS.

	▲ ADVERTÊNCIA Use sempre óculos de protecção quando estiver operando ou executando algum serviço de manutenção nesta ferramenta.
---	--

	▲ ADVERTÊNCIA Use sempre protecção contra o ruído ao operar esta ferramenta.
---	--

	▲ ADVERTÊNCIA Desligue sempre a alimentação de ar e desconecte a mangueira de alimentação de ar antes de instalar, remover ou ajustar qualquer acessório nesta ferramenta, ou antes de executar algum serviço de manutenção nesta ferramenta.
---	---

	▲ ADVERTÊNCIA Ferramentas accionadas pneumáticamente podem vibrar em uso. Vibração, movimentos repetitivos ou posições desconfortáveis podem ser prejudiciais às mãos e aos braços. Pare de usar a ferramenta caso ocorra algum desconforto, sensação de formigamento ou dor. Procure assistência médica antes de retornar ao trabalho.
---	---

	▲ ADVERTÊNCIA Não carregue a ferramenta segurando na mangueira.
---	---

	▲ ADVERTÊNCIA Não use mangueiras de ar ou adaptadores danificados, gastos ou deteriorados.
---	--

	▲ ADVERTÊNCIA Mantenha a posição do corpo equilibrada e firme. Não exagere quando operar esta ferramenta. Torques de reacção elevados podem ocorrer sob a pressão de ar recomendada.
---	--

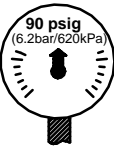
	▲ ADVERTÊNCIA Opere com pressão do ar Máxima de 90-100 psig (6,2-6,9 bar).
---	--

AJUSTES

AJUSTE DE TORQUE

Para ajustar o torque nestas Chaves Dinamométricas de Impulsão de Lâminas Duplas, proceda da seguinte maneira:

1. Remova o Bujão do Furo de Ajuste.
2. Gire o Eixo de Comando até o Parafuso de Ajuste de Torque estar visível na abertura.
3. Usando uma chave Allen de 1,5 mm, gire o Parafuso de Ajuste no sentido horário para aumentar o torque de saída e no sentido contrário aos do ponteiros do relógio para diminuir o torque de saída. Não gire o Bujão de Óleo.

AVISO

Faça todos os ajustes finais no serviço.

4. Reponha o Bujão do Furo de Ajuste.

COLOCANDO A FERRAMENTA EM FUNCIONAMENTO

LUBRIFICAÇÃO



Ingersoll-Rand No. 50

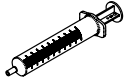

Ingersoll-Rand No. 67

Fluido Ingersoll-Rand
Número de Pedido
EQ106S-400-1

Use sempre um lubrificador de ar de linha com estas ferramentas. Nós recomendamos a seguinte Unidade Filtro-Lubrificador-Regulador:

For E.U.A. – No. C18-03-FKG0-28

Depois de cada 20.000 ciclos, ou como a experiência indicar, drene e encha o Conjunto do Comando da Unidade de Impulso como instruído neste manual usando o Kit de Reposição de Fluido (Número de Pedido EQ106S-K400). Lubrifique o comando hexagonal e o eixo de saída antes de montar.

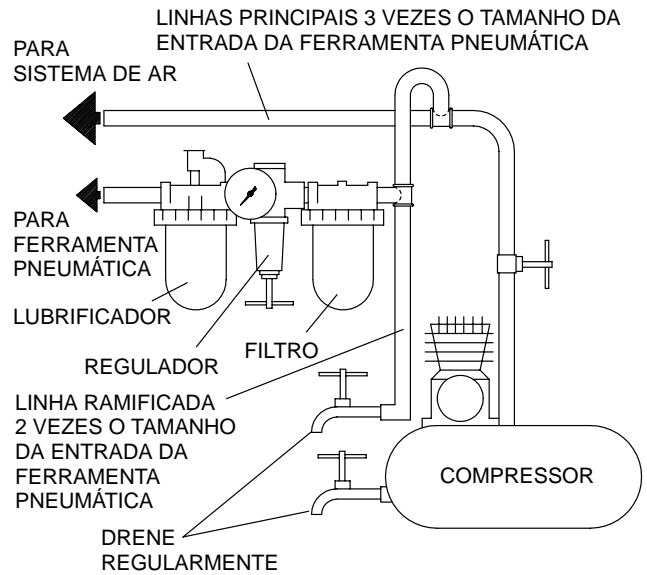

(Desenho TPD905-1)

ESPECIFICAÇÕES

Modelo	Tipo de Punho	Encabadouro/ Comando	Velocidade Livre	Intervalo de Torque Recomendado	
				Aperto Ligeiro Nm (pés-lb)	Batimento Duro Nm (pés-lb)
70P3	pistola	3/8" quadrada	7.000 rpm	50-76 (36-56)	48-65 (35-48)



PART NUMBER FOR ORDERING →

PART NUMBER FOR ORDERING →

	Motor Housing Assembly			Rear End Plate Assembly	70P3-A12
	for model 70P3	70P3-A40	24	Rear End Plate	70P3-12
	for model 70P3-EU	70P3-EU-A40	25	Rear Rotor Bearing	70P3-606
1	Motor Housing		26	Pin	70P3-297
	for model 70P3	70P3-B40	27	Cylinder Assembly	70P3-A3
	for model 70P3-EU	70P3-EU-B40	28	Cylinder Pin (2)	380SQ-298
1A	Nameplate		29	Rotor	70P3-53
	for model 70P3	70P3-301	30	Vane Packet (set of 9 Vanes)	70P3-42-9
	for model 70P3-EU	70P3-EU-301		Front End Plate Assembly	70P3-A11
1B	Warning Label		31	Front End Plate	70P3-11
	for model 70P3	WARNING-22-99	32	Front Rotor Bearing	500P-22
	for model 70P3-EU	EU-99	33	Motor Housing Cover O-ring (2)	70P3-236
2	Hose Joint	70P3-979	34	Motor Housing Cover Gasket	70P3-747
3	Roll Pin	70P3-232	35	Motor Housing Cover Assembly	70P3-A202
4	Throttle Bushing Assembly	70P3-A503	36	Roll Pin	70P3-232
5	O-ring	55P3-303	37	Motor Housing Cover Bolt (4)	90P4-58
6	Throttle Rod Assembly	70P3-A302		Mechanism Cover Assembly	70P3-A31
7	Throttle Rod Seal	100PQ-288	38	Mechanism Cover	70P3-31
8	Throttle Rod Spring	70P3-51	39	Adjustment Screw	180PQ-230
9	Throttle Spring	70P3-289	40	Adjustment Screw Plug Lock (2)	60P3-283
10	Reverse Valve	70P3-329	41	Plug Lock Spring	70P3-219
11	Reverse Valve Detent Spring	100PQ-568	42	Plug Lock Screw	70P3-230
12	Reverse Valve Detent Ball	EQ104S-929	43	Liner O-ring	EQ208S-237
13	Reverse Lever	100PQ-328	44	Housing Cap	380PQ-207
14	Reverse Lever Pin	180SQ-152		Rear Liner Cover Assembly	70P3-A212
15	Trigger	70P3-328	45	Rear Liner	70P3-212
16	Trigger Pin	EQ106P-265	46	Liner Cover O-ring	380PQ-236
17	Throttle Retaining Pin	100PQ-297	47	Rear Liner Seal	EQ106S-236
18	Exhaust Cover	70P3-978	48	Liner Assembly	380PQ-A203A
19	O-ring	100PQ-236	49	Liner Pin (4)	70P3-298
20	O-ring	EQ106P-283	50	Relief Valve	380PQ-222
21	Exhaust Element	70P3-505	51	Spring Guide Assembly	380PQ-A255
22	Exhaust Element	70P3-506	52	Spring Guide Seal	180PQ-272
23	Rubber Grip	70P3-2			

PART NUMBER FOR ORDERING 

PART NUMBER FOR ORDERING 

	Drive Shaft Assembly	70P3-A626	69	Bushing Spacer (3)	180PQ-229
53	Drive Shaft	70P3-626	70	Mechanism Cover Gasket	70P3-739
54	Socket Retaining Pin	5020-716	71	Mechanism Cover Bolt (4)	1410P-638
55	Retaining Pin Spring	401-718	72	Spring Washer (4)	900P-58
56	Front Liner Cover Assembly	70P3-A211	73	Blade (2)	380PQ-A627
57	Liner Cover Pin	70P3-239	74	Blade Spring (2)	380PQ-568
58	Oil Plug	180PQ-277	75	Information Label	55P3-99
59	Oil Plug Seal	EQ110P-288	76	Rotation Label	60P3-99
60	Oil Stop Cap Assembly	180PQ-A38	79	Hexagon Wrench	55P3-900
61	Stop Cap O-ring	EQ106S-288	80	Hexagon Wrench	70P3-900
62	Back-up Ring	380SQ-272	*	Motor Tune-up Kit (includes illustrated parts 25, 30, 32, 33[2], and 34)	70P3-K500
63	Front Liner Seal	380PQ-288	*	Mechanism Tune-up Kit (includes illustrated parts 41, 43, 46, 47, 52, 54, 55, 59, 61, 62, 64, 65, 69[3], and 74[2])	70P3-K600
64	Rear Liner Seal	180PQ-271			
65	Backup Ring	55P3-224			
	Mechanism Cover Assembly	70P3-A727			
66	Mechanism Cover	70P3-727			
67	Cover Bushing	180PQ-641			
68	Adjustment Hole Plug	180PQ-95			

* Not illustrated.

MAINTENANCE SECTION

WARNING

Always wear eye protection when operating or performing maintenance on this tool.

Always turn off the air supply and disconnect the air supply hose before installing, removing or adjusting any accessory on this tool or before performing any maintenance on this tool.

DISASSEMBLY

General Instructions

1. Do not disassemble the tool any further than necessary to replace or repair damaged parts.
2. When grasping a tool or part in a vise, always use leather-covered or copper-covered vise jaws to protect the surface of the part and help prevent distortion. This is particularly true of threaded members and housings.
3. Do not remove any part which is a press fit in or on an assembly unless the removal of that part is necessary for repairs or replacement.
4. Do not disassemble the tool unless you have a complete set of new gaskets and O-rings for replacements.

CHANGING THE MECHANISM FLUID

To change the Mechanism Fluid in the Impulse Mechanism, proceed as follows:

1. Remove the Rubber Grip (23).
2. Using a hex wrench, remove the four Mechanism Cover Bolts (71) and Lock Washers (72). Lift the Mechanism Cover (66) off the Motor Housing (1) over the Drive Shaft (53). Remove the Mechanism Cover Gasket (70).
3. Lift the assembled mechanism off the Rotor (29).
4. Using a 1.5 mm hex wrench, rotate the Torque Adjustment Screw (39) clockwise until the Screw stops. Rotate the Screw counterclockwise until it stops or makes six complete revolutions.
5. Using the special Tee Wrench furnished in the Tool Kit (Part No. 70P3-199), remove the Oil Plug (58) and Oil Plug Seal (59).
6. With the oil plug opening downward over a container, rotate the Drive Shaft to purge the fluid from the mechanism. As an alternate method, using the syringe from the Fluid Replacement Kit (Part No. EQ106S-K400) purge the fluid from the

first cavity. Then rotate the Drive shaft to expose the second cavity and purge the fluid using the syringe.

7. Using the syringe and fluid from the Fluid Replacement Kit (Part No. EQ106S-K400), fill the mechanism with the fluid furnished in the Kit. (Refer to Dwg. TPD1265)

NOTICE

DO NOT SUBSTITUTE ANY OTHER FLUID. Failure to use the fluid provided could damage the tool, increase maintenance and decrease performance. Use only clean fluid in these tools.

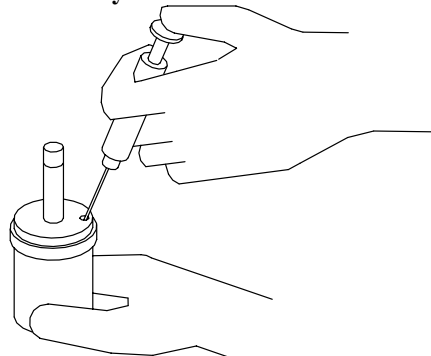

(Dwg. TPD1265)

8. Submerge the fill opening in the remainder of the fluid, and using a wrench, rotate the Drive Shaft to purge any remaining air from the system.
9. Thread the Oil Plug with the Oil Plug Seal into the mechanism until it is snug.
10. Using a 1.5 mm hex wrench, turn the Torque Adjustment Screw clockwise until it stops. This is the maximum torque position.
11. Wipe the outside of the mechanism dry and clean and remove the Oil Chamber Plug. Using the syringe, withdraw .3 cc of fluid.
12. Install the Oil Chamber Plug and tighten it between 20 and 25 in-lb (2.3 and 2.8 Nm) torque.
13. Position a new Mechanism Cover Gasket on the Motor Housing and install the assembled mechanism on the rotor shaft.
14. Place the Mechanism Cover over the Drive Shaft against the Housing and Gasket. Install the four Mechanism Cover Cap Screws and Lock Washers. Tighten each Screw between 45 and 50 in-lb (5.1 and 5.6 Nm) torque.
15. Install the Rubber Housing Boot on the tool.

MAINTENANCE SECTION

Disassembly of the Impulse Mechanism

1. Use a hooked wire to pull the Retaining Pin Spring (55) out of the end of the Drive Shaft (53) and remove the Socket Retaining Pin (54).
2. Remove the Rubber Grip (23).
3. Using a hex wrench, remove the four Cap Screws (71) and Lock Washers (72). Lift the Mechanism Cover (66) off the Motor Housing (1) over the Drive Shaft (53). Remove the Mechanism Cover Gasket (70).
4. Lift the assembled mechanism off the Rotor (29). Remove the Bushing Spacer (69).
5. With the oil plug opening downward over a container, rotate the Drive Shaft to purge the fluid from the mechanism. As an alternate method, using the syringe from the Fluid Replacement Kit (Part No. EQ106S-K400), purge the fluid from the first cavity. Then rotate the Drive Shaft to expose the second cavity and purge the fluid using the syringe.
6. Grasp the flats of the Housing Assembly (38) in vise jaws with the output end of the Drive Shaft downward.
7. Insert the pins of the spanner plug from the No. 70P3-199 Tool Kit into the two holes in the Housing Cap (44). Using a wrench on the plug, unscrew and remove the Housing Cap from the Housing Assembly. (Refer to Dwg. TPD1267)

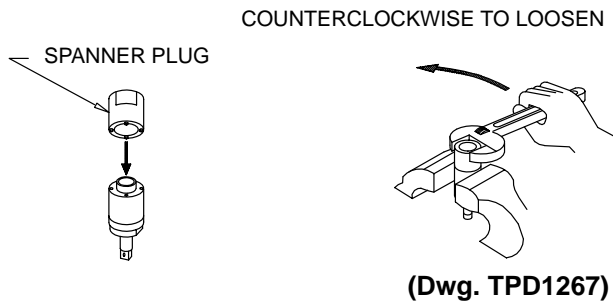

8. Stand the disassembly arbor from the Tool Kit, large end downward, on a workbench or the table of an arbor press. Insert the output end of the Drive Shaft into the central opening and either tap the Housing downward off the components or use the pressing sleeve in the Kit to press the Housing downward off the components. (Refer to Dwg. TPD1268)

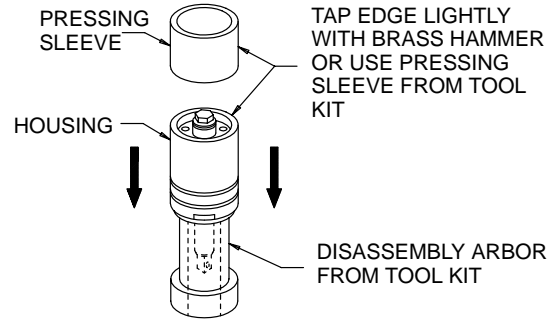

(Dwg. TPD1268)

9. Disassemble the components of the mechanism in the sequence shown in Drawing TPA1560 on Page 13.

Disassembly of the Motor

1. Grasp the Motor Housing (1) in vise jaws with the Motor Housing Cover (35) up.
2. Remove the Motor Housing Cover Bolts (37). Remove the Motor Housing Cover (35) and Motor Housing Cover Gasket (34) from the Motor Housing.
3. Secure the Motor Housing in vise jaws with the motor bore in a horizontal position and handle pointing down. Using a plastic hammer, lightly tap the Housing surrounding the motor bore to loosen the motor. From the front of the Housing, push on the Rotor (29) until the assembled motor begins to slide out of the rear of the Motor Housing. Grasp the Rear End Plate (24) and pull the assembled motor from the Motor Housing.
4. Remove the Front End Plate (31), Front End Plate Bearing (32), Cylinder Assembly (27) and Vanes (30) from the Rotor.
5. On the table of an arbor press, support the Rear End Plate (24) with blocks as close to the Rotor as possible and press the Rotor out of the Rear End Plate and Rear Rotor Bearing (25).
6. To remove the Rear Rotor Bearing from the Rear End Plate, use a small drift or pin punch through the central opening of the Rear End Plate to tap the Bearing out of the End Plate. (Refer to Dwg. TPD1271)

NOTICE

Do not enlarge or damage the shaft hole in the End Plate.

MAINTENANCE SECTION

ASSEMBLY

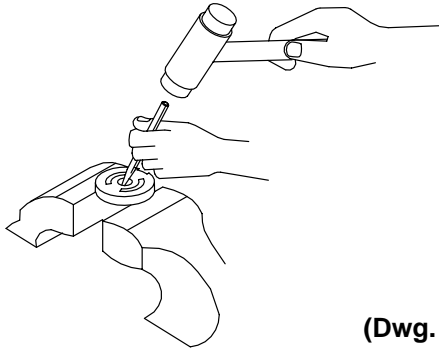

(Dwg. TPD1271)

- Using a pin punch, tap the Throttle Retaining Pin (17) out of the Handle. The Throttle Retaining Pin is protected by an embossed circular pad of metal. Insert the pin punch into the middle of the pad to locate the Pin. (Refer to Dwg. TPD1272)

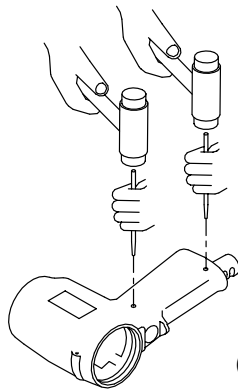

(Dwg. TPD1272)

- Grasp the Trigger (15) and pull the assembled throttle out of the Motor Housing.
- Using a pin punch and without damaging the Trigger, remove the Trigger Pin (16). Slide the Trigger off of the shaft of the Throttle Rod (6).
- Grasp the Reverse Lever (13) and pull the Reverse Valve (10) from the front of the Throttle Bushing Assembly. The Reverse Lever Detent Ball (12) and Reverse Lever Detent Spring (11) will fall out of the Reverse Valve. Take care not to lose them.
- Remove the Throttle Rod Assembly (6) from the rear of the Throttle Bushing.
- Remove the Throttle Spring (9) and Throttle Rod Seal (7) from the Throttle Rod.
- If it is necessary to replace the Reverse Lever or Reverse Valve, use a pin punch to tap out the Reverse Lever Pin (14) out of the Reverse Lever. Separate the Reverse Lever from the Reverse Valve.
- Unscrew and remove the Hose Joint (2).
- This will allow the Exhaust Cover (18) and Exhaust Elements (21 and 22) to be removed from the Hose Joint.
- Remove the O-ring (19) from the Motor Housing.

General Instructions

- When grasping a tool or part in a vise, always use leather-covered or copper-covered vise jaws to protect the surface of the part and help prevent distortion. This is particularly true of threaded members and housings.
- Always press on the inner ring of a ball-type bearing when installing the bearing on a shaft.
- Always press on the outer ring of a ball-type bearing when pressing the bearing into a bearing recess.
- Except for bearings and mechanism parts, always clean every part and wipe every part with a thin film of oil before installation.
- Wipe a thin film of mechanism fluid on all internal mechanism components before installing them in the mechanism.
- Apply a film of o-ring lubricant to every o-ring before installation.

Assembly of the Motor

- Install the O-ring (20) on the Hose Joint (2).
- Install the Exhaust Element (21) over the Exhaust Element (22) and insert both inside the Exhaust Cover (18). Install the Exhaust Cover containing both Elements on the Hose Joint until it seats.
- Install the O-ring (19) in the Motor Housing (1).
- Thread the Hose Joint with the Exhaust components into the Motor Housing and tighten to 30–35 ft-lb (40–47 Nm) torque.
- Install the Throttle Rod Seal (13) in the groove on the large hub of the Throttle Rod (6) and install the Throttle Spring (8) on the shaft of the Throttle Rod.
- Put the Reverse Lever (13) on the Reverse Valve (10) and secure it with the Reverse Lever Pin (16).
- Start the Reverse Valve into the Throttle Bushing (4). Install the Reverse Lever Detent Spring (11) in the hole in the Bushing. Set the Reverse Lever Detent Ball (12) on the Spring and while holding it in place, align the Ball with the detent hole in the Bushing. Push the Valve into the Bushing until the Reverse Lever Detent Ball seats in the detent hole.
- Insert the Throttle Rod, shaft end first, through the rear of the Throttle bushing and through the Reverse Valve so that the hub of the Throttle Rod seats against the end of the Throttle Bushing.
- Install the Trigger (15) on the Throttle Rod and secure it with the Trigger Pin (16).
- Install the Throttle Spring (9) with the small end over the hub of the Throttle Valve and slide the assembled unit into the Motor Housing.
- Install the Throttle Retaining Pin (17) in the Housing, making sure that it captures the Throttle Bushing Assembly.

MAINTENANCE SECTION

12. Using an arbor press and a piece of tubing that contacts the outer ring of the bearings, press the Front End Plate Bearing (32) into the Front End Plate (31) and the Rear End Plate Bearing (25) into the Rear End Plate (24). (Refer to Dwg. TPD1274)

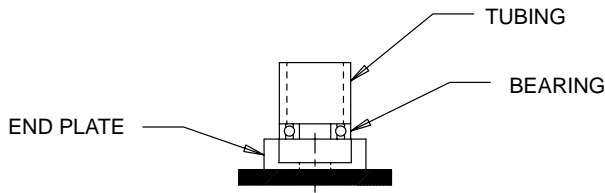

(Dwg. TPD1274)

13. Stand the Rotor (29) on the table of an arbor press. It should be upright on a flat metal plate having a clearance hole for the shaft. The shaft with the hex must be upward.
14. Place a 0.001" (0.025 mm) shim on the upward surface of the large portion of the rotor body. Using a piece of tubing that contacts the inner ring of the bearing, press the Front Rotor Bearing and Front End Plate, End Plate leading, onto the shaft of the Rotor until the End Plate contacts the shim. Remove the shim. (Refer to Dwg. TPD1275)

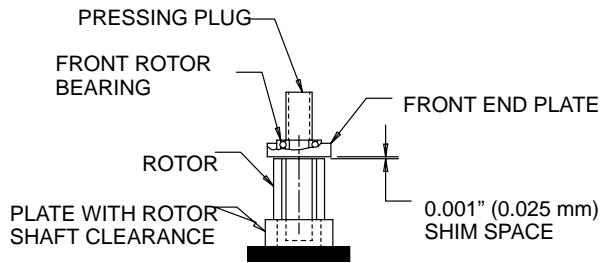

(Dwg. TPD1275)

15. Coat each Vane (30) with a thin film of oil and insert a Vane into each of the rotor vane slots with the straight edge of the Vane outward.
16. Install the Cylinder (27) over the Vanes and Rotor with the end of the Cylinder having the Front End Plate Alignment Pin (28) in the middle of the four holes positioned toward the Front End Plate. Make certain the Pin enters the hole in the face of the Front End Plate. (Refer to Dwg. TPD1276).

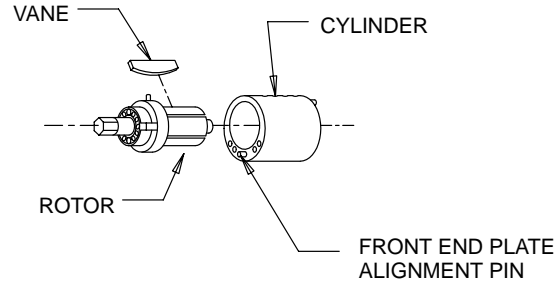

(Dwg. TPD1276)

17. Place the Rear End Plate and Bearing against the face of the Cylinder, Bearing end trailing.
18. Install the Motor Housing Cover O-rings (33) in the grooves in the rear of the Motor Housing.
19. Install the Motor Housing Cover Gasket (34) and Motor Housing Cover (35) on the rear of the Motor Housing. Secure it with the motor Housing Cover Bolts (37). Tighten to 45–50 in-lbs (5.1–5.6 Nm) torque.
20. Insert the assembly into the rear of the Motor Housing. It may be necessary to tap the assembly into position with a brass or plastic hammer. (Refer to Dwg. TPD1279)

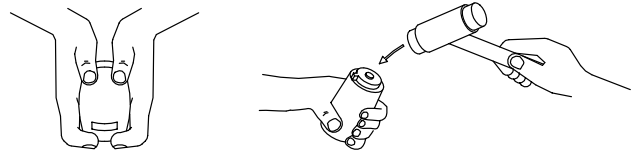

(Dwg. TPD1279)

MAINTENANCE SECTION

Assembly of the Impulse Mechanism

1. Insert the long shaft with the annular groove of the Spring Guide (51) into the central opening of the O-ring installer furnished with the Tool Kit (Part No. 70P3-199). Place the Spring Guide Seal (52) on the tapered end of the installer and roll the Seal up the taper and into the groove on the large body of the Spring Guide. (Refer to Dwg. TPD1281)

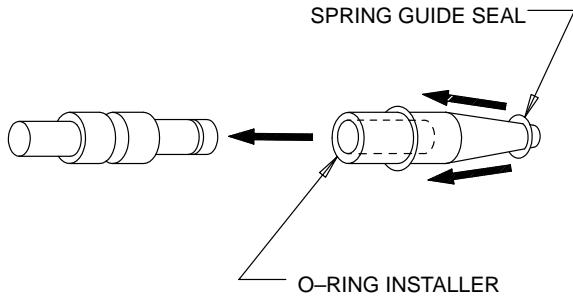

(Dwg. TPD1281)

2. Insert the Relief Valve (50), large end trailing, into the Liner (48). Insert the assembled Spring Guide, long hub with annular groove leading, into the Liner against the Relief Valve. (Refer to Dwg. TPD1282)

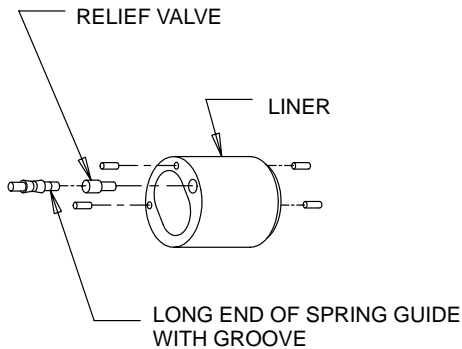

(Dwg. TPD1282)

3. Place a Blade (73) into one of the slots of the Drive Shaft (53) with the assembly pins inward.
4. From the opposite side of the Shaft, encircle each pin with a Blade Spring (74).
5. Install the assembly pins of the remaining Blade in the open ends of the Springs. (Refer to Dwg. TPD1283)

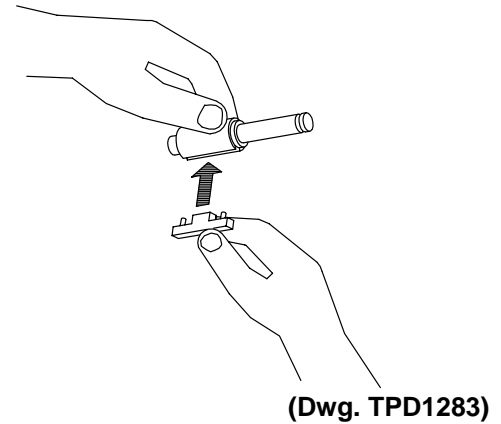

6. Compress the Springs with the Blades until both Blades are flush with the Drive Shaft and install the assembly in the Liner with the output end of the Drive Shaft protruding out the end of the Liner containing the Spring Guide. Make certain the ends of the Blades are flush with the ends of the Liner. (Refer to Dwg. TPD1284).

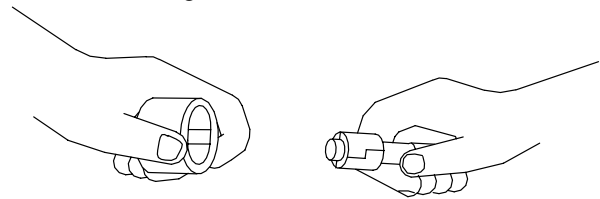

(Dwg. TPD1284)

7. Install the Rear Liner Seal (64) followed by the Seal Back-up Ring (65) on the Drive Shaft against the hub. (Refer to Dwg. TPD1285)

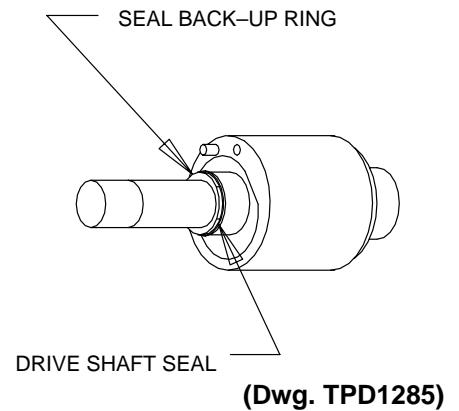

MAINTENANCE SECTION

8. The Torque Adjustment Screw (39) can only be installed from the liner end of the Mechanism Cover (38). If the Torque Adjustment Screw was removed, proceed as follows:
 - a. Insert a 1.5 mm hex wrench into the threaded hole for the Torque Adjustment Screw from the oil plug end of the Cover.
 - b. From the opposite end of the Cover, install the hex of the Torque Adjustment Screw onto the hex wrench.
 - c. Push the Screw and wrench toward the threaded hole until it contacts the face of the Cover.
 - d. While applying finger pressure to the rivet end of the Screw, rotate the wrench counterclockwise to thread the Screw into the Cover. Continue rotating the Screw until the rivet end stops against the face of the Cover.
 - e. Insert the two Adjustment Screw Plug Locks (40) and the Plug Lock Spring (41) into the crosshole leading to the Adjustment Screw. Thread the Plug Lock Screw (42) into the same hole to capture the components. (Refer to Dwg. TPD1286)

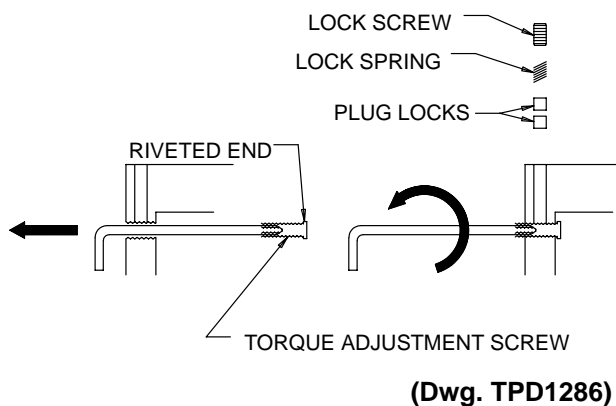

9. If the Oil Stop Cap Assembly (60) was removed from the Front Liner Cover (56), install the Stop Cap O-ring (61) and Back-up Ring (62) in the groove of the Cap and insert the assembly into the Cover. (Refer to Dwg. TPD1287)

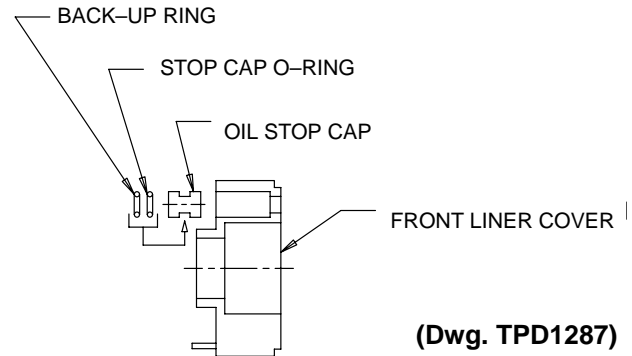

10. Align the pin holes in the face of the Rear Liner Cover (45) with the two Liner Pins (49) at the rear of the Liner and place the Cover against the Liner. A groove will be formed between the Liner and Cover for the Rear Liner Seal (47). Do not attempt to put the Seal in the groove at this time.
11. Align the pin holes in the Front Liner Cover (56) with the Pins in the front face of the Liner and place the Cover against the face of the Liner. Another groove will be formed between the Liner and Cover for the Front Liner Seal (63). Install both the Front and Rear Liner Seal in the grooves at this time and stand the assembly on the workbench with the output end of the Drive Shaft upward. (Refer to Dwg. TPD1288)

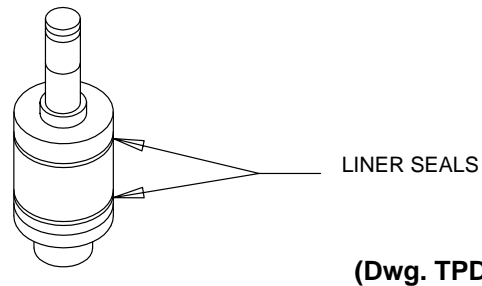

12. Apply a thin film of grease to the Liner O-ring (43) and install it in the forward bore of the Housing.
13. Lubricate the Liner Cover O-ring (46) and install it in the groove on the Rear Liner (45).
14. Lubricate the Front and Rear Liner Seals and after orienting the Housing to the proper position, install the Housing over the Liner.

MAINTENANCE SECTION

15. Grasp the flats of the Housing in vise jaws with the output spindle downward. Remove the Rear Liner Cover Assembly and put grease in the central opening of the Cover. (Refer to Dwg. TPD1289)

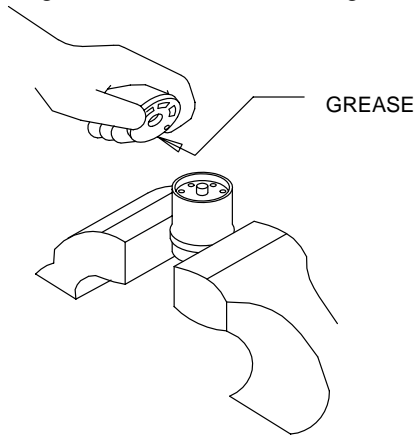

(Dwg. TPD1289)

16. Reinstall the Cover Assembly and use a hex wrench to push it below the threads at the rear of the Housing. (Refer to Dwg. TPD1290)

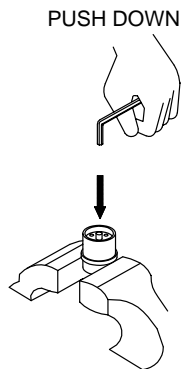

(Dwg. TPD1290)

17. Install the Housing Cap (44) and using the spanner plug furnished in the Tool Kit, tighten the Cap between 58–65 ft–lb (78–88 Nm) torque. (Refer to Dwg. TPD1291)

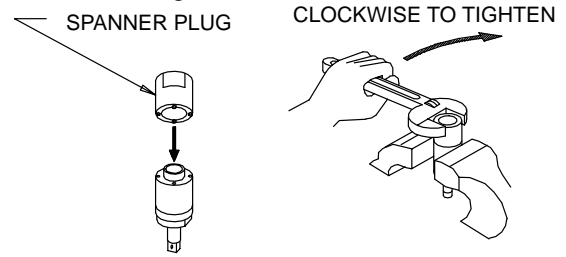

(Dwg. TPD1291)

18. Make certain the Drive Shaft rotates freely and then fill the mechanism with fluid and reassemble the tool as instructed in the section, **CHANGING THE MECHANISM FLUID**.
19. Install the Main Shaft Bushing (67) in the Mechanism Cover (66).
20. Install the Mechanism Cover Gasket (70) on the front of the Motor Housing Assembly.
21. Install the Mechanism Cover on the Gasket and Motor Housing and secure it with the Mechanism Cover Washers (72) and Mechanism Cover Bolts (68). Tighten to 35–52 ft–lb (44–72 Nm) torque.

NOTES