

## CLAMPING INSTRUCTIONS for SERIES DEMP PUSH-TO-START TORQUE CONTROL WRENCHES

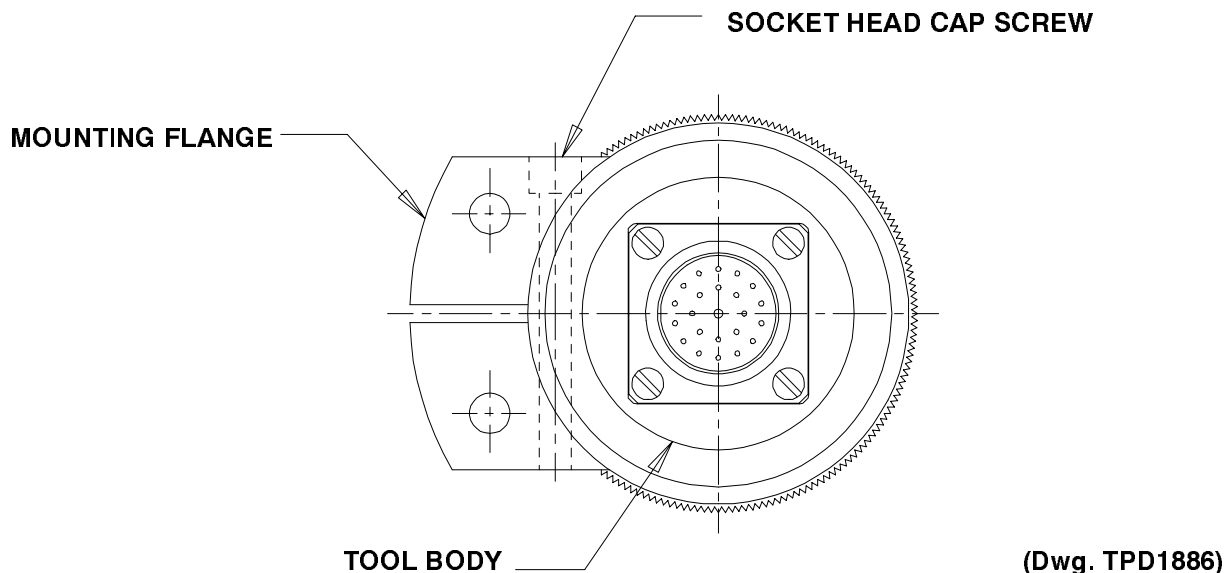

The Mounting Flange of all DC Electric Series DEMP Push-to-Start Torque Control Wrenches is attached to the Tool with a specific torque that is preset at the factory.

### CAUTION

**Do not loosen the Mounting Flange Clamp Screw or change the Mounting Flange position from the factory set position. Loosening the Clamp Screw will allow the Tool to rotate within the Flange causing the internal connectors to separate. This will make the Tool inoperable and possibly damage internal components.**

For additional information, contact Customer Engineering at (908) 782-6760.

### NOTICE

**The use of other than genuine Ingersoll-Rand replacement parts may result in decreased tool performance and increased maintenance, and may invalidate all warranties.**

**Ingersoll-Rand is not responsible for customer modification of tools for applications on which Ingersoll-Rand was not consulted.**

**Repairs should be made only by authorized, trained personnel. Consult your nearest Ingersoll-Rand Servicenter.**

**It is the responsibility to place the information in this manual into the hands of the operator.**

Refer All Communications to the Nearest  
Ingersoll-Rand Office or Distributor.

© Ingersoll-Rand Company 1996

Printed in U.S.A.

**INGERSOLL-RAND®**  

---

**PROFESSIONAL TOOLS**

