

MAINTENANCE SECTION COVERING GEAR CASE MODULES for SERIES DEF40 FIXTURE MOUNTED DC ELECTRIC TORQUE CONTROL WRENCHES with TRANSDUCERS

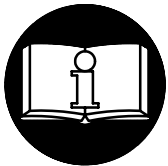

⚠ WARNING

**IMPORTANT SAFETY INFORMATION ENCLOSED.
READ ALL THESE INSTRUCTIONS BEFORE PLACING TOOL IN SERVICE OR
OPERATING THIS TOOL AND SAVE THESE INSTRUCTIONS.
IT IS THE RESPONSIBILITY OF THE EMPLOYER TO PLACE THE INFORMATION
IN THIS MANUAL INTO THE HANDS OF THE OPERATOR.
FAILURE TO OBSERVE THE FOLLOWING WARNINGS COULD RESULT IN INJURY.**

Disconnect the Power Cord from the receptacle before performing any maintenance on this tool.



This symbol is to alert the user and service personnel to the presence of uninsulated dangerous voltage that will cause a risk of electric shock.



This symbol is to alert the user and service personnel to the presence of important operating instructions that must be read and understood to prevent personal injury, electrical shock or damage to the equipment.

**WHEN USING ELECTRIC TOOLS, BASIC SAFETY PRECAUTIONS SHOULD
ALWAYS BE FOLLOWED TO REDUCE THE RISK OF FIRE, ELECTRIC SHOCK
AND PERSONAL INJURY, INCLUDING THE FOLLOWING.**

PLACING TOOL IN SERVICE

- Use only with Series TMAD Controllers.
- Always operate, inspect and maintain this tool in accordance with all regulations (local, state, federal and country), that may apply to hand held/hand operated electric tools.
- Inspect tool cords periodically and if damaged, have them repaired by an authorized service facility.
- Do not remove any labels. Replace any damaged label.

USING THE TOOL

- Always wear eye protection when operating or performing maintenance on this tool.

- Power tools can vibrate in use. Vibration, repetitive motions, or uncomfortable positions may be harmful to your hands and arms. Stop using any tool if discomfort, tingling feeling or pain occurs. Seek medical advice before resuming use.
- **Guard Against Electric Shock.** Prevent body contact with earthed or grounded surfaces. For example; pipes, radiators, ranges, refrigerator enclosures.
- **Don't abuse Cord.** Never carry tool by cord or yank it to disconnect from receptacle. Keep cord from heat, oil, and sharp edges.
- **Keep work area clean.** Cluttered areas and benches invite injuries.

(Continued on page 3-2)

NOTICE

The use of other than genuine Ingersoll-Rand replacement parts may result in personal injury, decreased tool performance and increased maintenance, and may invalidate all warranties.

Have your tool repaired by a qualified person. This electric tool is in accordance with the relevant safety requirements. Repairs should only be carried out by qualified persons using original spare parts, otherwise this may result in considerable danger to the user.

Repairs should be made only by authorized, trained personnel. Consult your nearest Ingersoll-Rand Authorized Servicenter.

Refer All Communications to the Nearest
Ingersoll-Rand Office or Distributor.

© Ingersoll-Rand Company 2000

Printed in U.S.A.





WARNING

FAILURE TO OBSERVE THE FOLLOWING WARNINGS COULD RESULT IN INJURY.

USING THE TOOL (*Continued*)

- **Consider work area environment.** Don't expose power tools and chargers to water. Keep work area well lighted. Do not use tool in explosive or flammable atmospheres.
- **Keep bystanders and children away.** Do not permit unauthorized personnel to operate this tool, or touch tool or cord.
- **Store idle tools.** When not in use, tools should be stored in a dry, high or locked up place, out of reach of children.
- **Don't force tool.** It will do the job better and more safely at the rate for which it was intended.
- **Use the right tool.** Do not force a small tool or attachment to do the job of a heavy-duty tool.
- **Do not use a tool for a purpose for which it is not intended.** Example: Do not use a screwdriver as a drill.
- **Dress properly.** Do not wear loose clothing or jewelry. They can be caught in moving parts. Rubber gloves and non-skid footwear are recommended when working outdoors. Wear protective hair covering to contain long hair.
- **Secure work.** Use clamps or a vise to hold work. Operators often need both hands to perform job functions.
- **Don't overreach.** Keep proper footing, balance, and a firm grip on the tool at all times.
- **Maintain tools with care.** Keep tools clean for better and safer performance. Follow instructions for lubricating and changing accessories. Inspect tool cords periodically and if damaged, have them repaired by an authorized service facility. Inspect extension cords periodically and replace if damaged. Keep handles dry, clean, and free from oil and grease.
- **Remove adjusting keys and wrenches.** Form habit of checking to see that keys and adjusting wrenches are removed from tool before turning it on.
- **Avoid unintentional starting.** Don't carry tool with finger on switch.
- **Do not drop or abuse the tool.**
- **Whenever a tool is not being used, position the Power Switch to the "OFF" position and unplug the power cord.**
- **Stay alert.** Watch what you are doing. Use common sense. Do not operate tool when you are tired.
- **Check damaged parts.** Before further use of the tool, a guard or other part that is damaged should be carefully checked to determine that it will operate properly and perform its intended function. Check for alignment of moving parts, binding of moving parts, breakage of parts, mounting, and any other conditions that may affect its operation. A guard or other part that is damaged should be properly repaired or replaced by an authorized service center unless otherwise indicated elsewhere in this operation manual.
- **Have defective switches replaced by an authorized service center.**
- **Do not use the tool if the switch does not turn it on and off.**
- **Whenever the Angle Head is installed or repositioned, the Throttle Lever must be positioned so that reaction torque will not tend to retain the throttle in the "ON" position.**
- **When installing or removing the output device on a tool, ALWAYS hold the tool by the hex on the Gear Case while tightening the Coupling Nut. NEVER grasp the composite tool body or handle in vise jaws to restrain the tightening torque of the Coupling Nut. Such practice will result in damage to the tool.**
- **Do not use power units and gear trains that exceed the capability of the output device.**
- **The Tube Nut Attachment has an opening on the front side for construction and application purposes. DO NOT, under any circumstance place your fingers in this opening.**
- **The Torque Reaction Bar must be positioned against a positive stop. Do not use the Bar as a dead handle and take all precautions to make certain the operator's hand cannot be pinched between the Bar and a solid object.**
- **When operated continuously for long periods of time, Series D Nutrunners may become hot at the spindle end of the tool. Take all precautions necessary to avoid skin contact with the hot surfaces. Prolonged contact may result in burns.**
- **All Series D Torque Control Wrenches and Nutrunners with reverse capability have rotational arrows molded into the housing in the area of the reversing mechanism. When the direction switching device is positioned nearest the molded circular arrow with an "F" in the center, spindle rotation will be forward or clockwise direction. When the direction switching device is positioned nearest the molded circular arrow with an "R" in the center, spindle rotation will be reverse or counter-clockwise direction.**

WARNING LABEL IDENTIFICATION

	▲ WARNING
	Always wear eye protection when operating or performing maintenance on this tool.

	▲ WARNING
	Powered tools can vibrate in use. Vibration, repetitive motions or uncomfortable positions may be harmful to your hands and arms. Stop using any tool if discomfort, tingling feeling or pain occurs. Seek medical advice before resuming use.

	▲ WARNING
	INDOOR USE ONLY.

	▲ WARNING
	Always wear hearing protection when operating this tool.

	▲ WARNING
	Do not carry the tool by the cord.

	▲ WARNING
	The Torque Reaction Bar must be positioned against a positive stop. Do not use the Bar as a dead handle and take all precautions to make certain the operator's hand cannot be pinched between the Bar and a solid object.

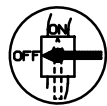
	▲ WARNING
	Always turn off the electrical supply and disconnect the power cord before installing, removing or adjusting any accessory on this tool, or before performing any maintenance on this tool.

	▲ WARNING
	Do not use damaged, frayed or deteriorated power cords.

	▲ WARNING
	Keep body stance balanced and firm. Do not overreach when operating this tool.

LUBRICATION



Ingersoll-Rand No. 67

After each 250,000 cycles, or four months of operation or as experience indicates, inject 3 to 4 cc of Ingersoll-Rand No. 67 Grease into the Grease Fitting (301) in the Gear Case Assembly (300).

**SERIES DEF GEAR UNITS FOR FIXTURE MOUNTED
DC ELECTRIC TORQUE CONTROL WRENCHES WITH TRANSDUCERS**

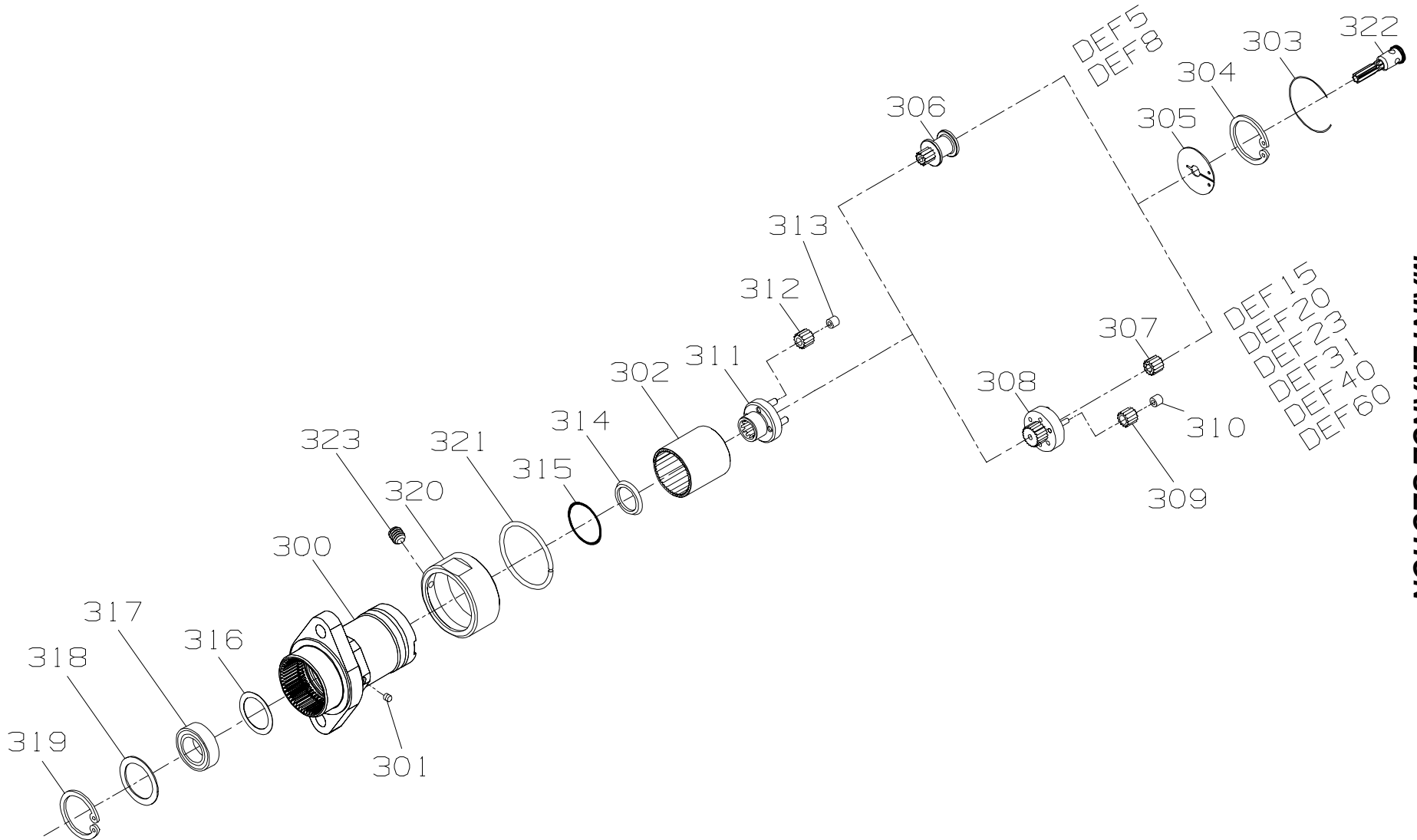

3-4

(Dwg. TPC658)



PART NUMBER FOR ORDERING



		DEF5	DEF8	DEF15	DEF20
+	Gear Case Module	DEF5-M37	DEF8-M37	DEF15-M37	DEF20-M37
300	Gear Case Assembly	DEF40-B787	DEF140-B787	DEF40-B787	DEF40-B787
301	Grease Fitting	D0F9-879	D0F9-879	D0F9-879	D0F9-879
302	Ring Gear	DEF40-406	DEF40-406	DEF40-406	DEF40-406
303	Ring Gear Retainer	M004-29	M004-29	M004-29	M004-29
304	Retainer Snap Ring	4E-118	4E-118	4E-118	4E-118
305	Gear Retainer	DEA40-81	DEA40-81	DEA40-81	DEA40-81
306	Drive Coupling	DAA9-17	DAA14-17	—	—
307	Rotor Pinion	—	—	DAA25-17	DAA35-17
308	Planet Gear Head	—	—	DAA25-216	DAA35-216
309	Gear Head Planet Gear Assembly (4)	—	—	—	6WTP-A10
310	Gear Head Planet Gear Bearing	—	—	—	WFS182-654
309	Gear Head Planet Gear (3)	—	—	4RLN-10	—
310	Gear Head Planet Gear Bearing (3)	—	—	6WTM-500	—
311	Planet Gear Spindle	DAA9-8	DAA14-8	DAA25-8	DAA9-8
312	Spindle Planet Gear Assembly (4 for DEF5-M37; 3 for DEF20-M37)	6WTP-A10	—	—	6WTN-A10
313	Spindle Planet Gear Bearing	WFS182-654	—	—	7AH-500
312	Spindle Planet Gear (4 for DEF15-M37; 3 for all others)	—	4RLL-10	6WTM-10	—
313	Spindle Planet Gear Bearing (4 for DEF15-M37; 3 for all others)	—	6WTM-500	6WTM-500	—
314	Grease Shield Support	DAA40-5	DAA40-5	DAA40-5	DAA40-5
315	Shield Support O-ring	DAA40-606	DAA40-606	DAA40-606	DAA40-606
316	Grease Shield	DAA40-701	DAA40-701	DAA40-701	DAA40-701
317	Gear Case Bearing	R1602-510	R1602-510	R1602-510	R1602-510
318	Bearing Washer	DEM40-81	DEM40-81	DEM40-81	DEM40-81
319	Retainer	W64-118	W64-118	W64-118	W64-118
320	Coupling Nut	DEM40-27	DEM40-27	DEM40-27	DEM40-27
321	Retainer	DEM40-29	DEM40-29	DEM40-29	DEM40-29
322	Pinion Coupler	DEM40-17	DEM40-17	DEM40-17	DEM40-17
323	Set Screw	61H-669	61H-669	61H-669	61H-669

MAINTENANCE SECTION

3-5

+ To assure proper gear placement, refer to **Gear Identification Chart** on page 3-7.

PART NUMBER FOR ORDERING



		DEF23	DEF31	DEF40	DEF60
+	Gear Case Module	DEF23-M37	DEF31-M37	DEF40-M37	DEF60-M37
300	Gear Case Assembly	DEF40-B787	DEF40-B787	DEF40-B787	DEF40-B787
301	Grease Fitting	D0F9-879	D0F9-879	D0F9-879	D0F9-879
302	Ring Gear	DEM40-406	DEM40-406	DEM40-406	DEM60-406
303	Ring Gear Retainer	M004-29	M004-29	M004-29	M004-29
304	Retainer Snap Ring	4E-118	4E-118	4E-118	4E-118
305	Gear Retainer	DEA40-81	DEA40-81	DEA40-81	DEA40-81
306	Rotor Adapter	—	—	—	—
307	Rotor Pinion	4RLM-17	DAA35-17	—	—
308	Planet Gear Head	DAA40-216	DEA31-216	DAP40-216	DEP40-216
309	Gear Head Planet Gear Assembly (3)	—	DEA31-A10	—	—
310	Gear Head Planet Gear Bearing	—	7AH-500	—	—
309	Gear Head Planet Gear (3)	4RLM-10	—	4RLL-10	DAA40-10
310	Gear Head Planet Gear Bearing (3)	6WTM-500	—	6WTM-500	DAA40-500
311	Planet Gear Spindle	DAA40-8	DEA31-8	DAA9-8	DAA40-8
312	Spindle Planet Gear Assembly (4 for DEF40-M37; 3 for all others)	—	6WTN-A10	6WTP-A10	6WTL-A10
313	Spindle Planet Gear Bearing	—	DAA40-500	WFS182-654	7AJ-500
312	Spindle Planet Gear (3)	DAA40-10	—	—	—
313	Spindle Planet Gear Bearing (3)	DAA40-500	—	—	—
314	Grease Shield Support	DAA40-5	DAA40-5	DAA40-5	DAA40-5
315	Shield Support O-ring	DAA40-606	DAA40-606	DAA40-606	DAA40-606
316	Grease Shield	DAA40-701	DAA40-701	DAA40-701	DAA40-701
317	Gear Case Bearing	R1602-510	R1602-510	R1602-510	R1602-510
318	Bearing Washer	DEM40-81	DEM40-81	DEM40-81	DEM40-81
319	Retainer	W64-118	W64-118	W64-118	W64-118
320	Coupling Nut	DEM40-27	DEM40-27	DEM40-27	DEM40-27
321	Retainer	DEM40-29	DEM40-29	DEM40-29	DEM40-29
322	Pinion Coupler	DEM40-17	DEM31-17	DEM40-17	DEM60-17
323	Set Screw	61H-669	61H-669	61H-669	61H-669

MAINTENANCE SECTION

+ To assure proper gear placement, refer to **Gear Identification Chart** on page 3-7.

GEAR IDENTIFICATION CHART

PART NUMBER	PART NAME	ILLUS. NO.	NUMBER OF TEETH	
			EXTERNAL	INTERNAL
DAA9-17	Drive Coupling	306	12	7
DAA14-17	Drive Coupling	306	7	7
4RLM-17	Rotor Pinion	307	19	7
DAA35-17	Rotor Pinion	307	17	7
DAA25-17	Rotor Pinion	307	14	7
DAA25-216	Planet Gear Head	308	21	—
DAA35-216	Planet Gear Head	308	12 •	—
DAP40-216	Planet Gear Head	308	12 •	—
DAA40-216	Planet Gear Head	308	9 #	—
DEA31-216	Planet Gear Head	308	7	—
DEP40-216	Planet Gear Head	308	9 #	—
4RLL-10	Planet Gear	309 & 312	20 +	—
DAA40-10	Planet Gear	309 & 312	20 +	—
DEA31-10	Planet Gear	309	20 +	—
4RLM-10	Planet Gear	309	14 %	—
6WTP-10	Planet Gear	309 & 312	18	—
4RLN-10	Planet Gear	309	17	—
6WTL-10	Planet Gear	312	20 +	—
6WTN-10	Planet Gear	312	16	—
6WTM-10	Planet Gear	312	14 %	—

- Gear Head DAP40-216 can be distinguished from Gear Head DAA35-216 by the additional three holes in the face of the Gear Head.
- # Gear Head DAA40-216 can be distinguished from Gear Head DEP40-216 by the size of the gear shafts. DAA40-216 shafts are a 3 mm diameter while DEP40-216 shafts are a 4 mm diameter.
- + Gear DAA40-10 can be distinguished from the other twenty tooth gears by the annular groove across the center of the gear teeth. Gear 4RLL-10 has a 5 mm central opening for the Bearing. The differences between Gears DEA31-10 and 6WTL-10 are not obvious by visual inspection and these Gears **MUST** be tagged for identification when removed from a gear train.
- % Gear 4RLM-10 is marked with red stain and Gear 6WTM-10 is marked with white stain. If the stains are not visible when the gears are removed, tag the gears for future identification.

MAINTENANCE SECTION

Disassembly of the Gear Case

1. Grasp the Gear Case Assembly (300) in copper-covered vise jaws with the assembled motor upward, and using a wrench on the flats of the Housing Coupling Nut (320), loosen the joint and remove the tool from the vise. Remove set screw (323) and unscrew the Gear Case from the Housing. Remove the Retainer (321) and slide the Coupling Nut off the Gear Case.
2. Pull the Pinion Coupler (322) out of the Gear Case and use snap ring pliers to remove the Retainer Snap Ring (304) from the motor end of the Gear Case and slide the Gear Retainer (305) out of the Gear Case.
3. **For DEF5 and DEF8 modules**, remove the Rotor Adapter (306).
For DEF15, DEF20, DEF23 and DEF31 modules, remove the Rotor Pinion (307), Planet Gear Head (308), Planet Gears (309) and Planet Gear Bearings (310).
For DEF40 and DEF60 modules, remove the Planet Gear Head (308), Planet Gears (309) and Planet Gear Bearings (310).
4. Slide the Spindle Planet Gears (312) and Spindle Planet Gear Bearings (313) off the shafts of the Planet Gear Spindle (311).
5. Work a pointed probe under the Ring Gear Retainer (303) and spiral it out of the Gear Case.
6. Slide the Ring Gear (302) out of the Gear Case.
7. With the motor end of the Gear Case standing on the table of an arbor press, carefully press the Planet Gear Spindle out of the Gear Case Bearing (317). Remove the Grease Shield Support (314) and Shield Support O-ring (315) from the hub of the Planet Gear Spindle.
8. Use snap ring pliers to remove the Retainer Snap Ring (319) and slide the Bearing Washer (318), Bearing (317) and Bushing (318) out of the Gear Case.

Assembly of the Gear Case.

1. Install the Grease Shield Support (314), small edge trailing, onto the hub of the Gear Head Spindle (311). Install the Shield Support O-ring (315) on the Support.
2. Support the pin end of the Spindle on a steel rod long enough to keep the Gear Case (300) from contacting the table of an arbor press. Position the Gear Case, external thread upward, on the Spindle. Install the Grease Shield (316) in the Gear Case and press the Gear Case Bearing (317) onto the shaft of the Planet Gear Spindle. Press the Bearing until it enters the Gear Case and bottoms against the Shield Support.

3. Insert the Bearing Washer (318) on top of the bearing and use snap ring pliers to install the Retainer (319)
4. Slide the Ring Gear (302) into the motor end of the Gear Case until it stops against the shoulder of the Gear Case.
5. Install the Ring Gear Retainer (303) in the internal groove of the Gear Case to retain the Ring Gear.
6. Install a Spindle Planet Gear (312) and Spindle Planet Gear Bearing (313) on each shaft of the Spindle. Make certain the teeth of the Planet Gears mesh with the teeth of the Ring Gear.
7. Work 3 to 4 cc of Ingersoll-Rand No. 67 Grease into the gear train.
8. **For DEF5 and DEF8 modules**, install the Drive Coupling (306), gear teeth first, into the Gear Case. Make certain the gear teeth mesh with the teeth of the Planet Gears.
For DEF15, DEF20, DEF23, DEF31, DEF40 and DEF60 modules, install the Planet Gear Head (308) into the Gear Case.
9. **For DEF15, DEF20, DEF23, DEF31, DEF40 and DEF60 modules**, install a Planet Gear (309) and Planet Gear Bearing (310) on each of the pins on the Planet Gear Head. Make certain the teeth on the shaft of the Gear Head mesh with the teeth of the Spindle Planet Gears.
10. **For DEF15, DEF20, DEF23 and DEF31 modules**, install the Rotor Pinion (307) between the Planet Gears.
11. Slide the Gear Retainer (305) into the Gear Case and using snap ring pliers, install the Retainer Snap Ring (304) in the internal groove of the Gear Case.
12. Slide Coupling Nut (320) onto the Gear Case and install Retainer (321) in the groove on the Gear Case.
13. Slide the Gear Case onto the Motor Housing and engage the teeth of the Pinion Coupler (322) with the teeth of the Drive Coupling (306) or Rotor Pinion (307). It may be necessary to rotate the Spindle to mesh the teeth properly while threading the Housing Coupling Nut (320) onto the Motor Housing. Tighten the joint between 20 and 25 ft-lb (27 and 34 Nm) torque.
14. Install and tighten Grease Fitting (301) and set Screw (323).

MAINTENANCE SECTION

TROUBLESHOOTING GUIDE

Trouble	Probable Cause	Solution
Gear case gets hot	Excessive grease	Clean and inspect the Gear Case and gearing parts and lubricate as instructed in the assembly instructions.
	Worn or damaged parts	Clean and inspect the Gear Case and gearing. Replace worn or broken components.

NOTICE

SAVE THESE INSTRUCTIONS. DO NOT DESTROY.

NOTES

NOTES