

MAINTENANCE SECTION COVERING FIXTURE MOUNTED POWER MODULES for SERIES DEM120 AND DEF150 TORQUE CONTROL WRENCHES

⚠ WARNING

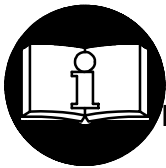

IMPORTANT SAFETY INFORMATION ENCLOSED.

READ ALL THESE INSTRUCTIONS BEFORE PLACING TOOL IN SERVICE OR OPERATING THIS TOOL AND SAVE THESE INSTRUCTIONS.

IT IS THE RESPONSIBILITY OF THE EMPLOYER TO PLACE THE INFORMATION IN THIS MANUAL INTO THE HANDS OF THE OPERATOR.

FAILURE TO OBSERVE THE FOLLOWING WARNINGS COULD RESULT IN INJURY.

Disconnect the Power Cord from the receptacle before performing any maintenance on this tool.



This symbol is to alert the user and service personnel to the presence of uninsulated dangerous voltage that will cause a risk of electric shock.



This symbol is to alert the user and service personnel to the presence of important operating instructions that must be read and understood to prevent personal injury, electrical shock or damage to the equipment.

WHEN USING ELECTRIC TOOLS, BASIC SAFETY PRECAUTIONS SHOULD ALWAYS BE FOLLOWED TO REDUCE THE RISK OF FIRE, ELECTRIC SHOCK AND PERSONAL INJURY, INCLUDING THE FOLLOWING.

PLACING TOOL IN SERVICE

- Use only with Ingersoll-Rand Series Controllers.
- Always operate, inspect and maintain this tool in accordance with all regulations (local, state, federal and country), that may apply to hand held/hand operated electric tools.
- Inspect tool cords periodically and if damaged, have them repaired by an authorized service facility.
- Do not remove any labels. Replace any damaged label.

USING THE TOOL

- Always wear eye protection when operating or performing maintenance on this tool.
- Power tools can vibrate in use. Vibration, repetitive motions, or uncomfortable positions may be

harmful to your hands and arms. Stop using any tool if discomfort, tingling feeling or pain occurs. Seek medical advice before resuming use.

- **Guard Against Electric Shock.** Prevent body contact with earthed or grounded surfaces. For example; pipes, radiators, ranges, refrigerator enclosures.
- **Don't abuse Cord.** Never carry tool by cord or yank it to disconnect from receptacle. Keep cord from heat, oil, and sharp edges.
- **Keep work area clean.** Cluttered areas and benches invite injuries.
- **Consider work area environment.** Don't expose power tools and chargers to water. Keep work area well lighted. Do not use tool in explosive or flammable atmospheres.

(Continued on page 2-2)

NOTICE

The use of other than genuine Ingersoll-Rand replacement parts may result in personal injury, decreased tool performance and increased maintenance, and may invalidate all warranties.

Have your tool repaired by a qualified person. This electric tool is in accordance with the relevant safety requirements. Repairs should only be carried out by qualified persons using original spare parts, otherwise this may result in considerable danger to the user.

Repairs should be made only by authorized, trained personnel. Consult your nearest Ingersoll-Rand Authorized Servicenter.

Refer All Communications to the Nearest
Ingersoll-Rand Office or Distributor.

© Ingersoll-Rand Company 1999

Printed in U.S.A.

INGERSOLL-RAND®
PROFESSIONAL TOOLS



FAILURE TO OBSERVE THE FOLLOWING WARNINGS COULD RESULT IN INJURY.

USING THE TOOL (*Continued*)

- **Keep bystanders and children away.** Do not permit unauthorized personnel to operate this tool, or touch tool or cord.
- **Store idle tools.** When not in use, tools should be stored in a dry, high or locked up place, out of reach of children.
- **Don't force tool.** It will do the job better and more safely at the rate for which it was intended.
- **Use the right tool.** Do not force a small tool or attachment to do the job of a heavy-duty tool.
- **Do not use a tool for a purpose for which it is not intended.** Example: Do not use a screwdriver as a drill.
- **Dress properly.** Do not wear loose clothing or jewelry. They can be caught in moving parts. Rubber gloves and non-skid footwear are recommended when working outdoors. Wear protective hair covering to contain long hair.
- **Secure work.** Use clamps or a vise to hold work. Operators often need both hands to perform job functions.
- **Don't overreach.** Keep proper footing, balance, and a firm grip on the tool at all times.
- **Maintain tools with care.** Keep tools clean for better and safer performance. Follow instructions for lubricating and changing accessories. Inspect tool cords periodically and if damaged, have them repaired by an authorized service facility. Inspect extension cords periodically and replace if damaged. Keep handles dry, clean, and free from oil and grease.
- **Remove adjusting keys and wrenches.** Form habit of checking to see that keys and adjusting wrenches are removed from tool before turning it on.
- **Avoid unintentional starting.** Don't carry tool with finger on switch.
- **Do not drop or abuse the tool.**
- **Whenever a tool is not being used, position the Power Switch to the "OFF" position and unplug the power cord.**
- **Stay alert.** Watch what you are doing. Use common sense. Do not operate tool when you are tired.
- **Check damaged parts.** Before further use of the tool, a guard or other part that is damaged should be carefully checked to determine that it will operate properly and perform its intended function. Check for alignment of moving parts, binding of moving parts, breakage of parts, mounting, and any other conditions that may affect its operation. A guard or other part that is damaged should be properly repaired or replaced by an authorized service center unless otherwise indicated elsewhere in this operation manual.
- **Have defective switches replaced by an authorized service center.**
- **Do not use the tool if the switch does not turn it on and off.**
- **Whenever the Angle Head is installed or repositioned, the Throttle Lever must be positioned so that reaction torque will not tend to retain the throttle in the "ON" position.**
- **When installing or removing the output device on a tool, ALWAYS hold the tool by the hex on the Gear Case while tightening the Coupling Nut. NEVER grasp the composite tool body or handle in vise jaws to restrain the tightening torque of the Coupling Nut. Such practice will result in damage to the tool.**
- **Do not use power units and gear trains that exceed the capability of the output device.**
- **The Tube Nut Attachment has an opening on the front side for construction and application purposes. DO NOT, under any circumstance place your fingers in this opening.**
- **The Torque Reaction Bar must be positioned against a positive stop. Do not use the Bar as a dead handle and take all precautions to make certain the operator's hand cannot be pinched between the Bar and a solid object.**
- **When operated continuously for long periods of time, Series D Nutrunners may become hot at the spindle end of the tool. Take all precautions necessary to avoid skin contact with the hot surfaces. Prolonged contact may result in burns.**
- **All Series D Torque Control Wrenches and Nutrunners with reverse capability have rotational arrows molded into the housing in the area of the reversing mechanism. When the direction switching device is positioned nearest the molded circular arrow with an "F" in the center, spindle rotation will be forward or clockwise direction. When the direction switching device is positioned nearest the molded circular arrow with an "R" in the center, spindle rotation will be reverse or counter-clockwise direction.**
- **Series DEPTS Tools are designed to generate torque that has a reaction greater than the ability of the operator to absorb. DO NOT, under any circumstances, operate Series DEPTS Tools without a torque reaction, restraining device attached to the rear of the Tool. For information and recommendations describing suitable devices, contact Ingersoll-Rand.**
- **Do not allow the clevis fastener on Series DEPTS Tools to loosen. Movement of the tool in the clevis will create a pinch hazard to the operator and may increase wear damage to the cord and electrical connections.**

WARNING LABEL IDENTIFICATION

	<p>▲ WARNING</p> <p>Always wear eye protection when operating or performing maintenance on this tool.</p>
-----------------------------------------------------------------------------------	------------------------------------------------------------------------------------------------------------------

	<p>▲ WARNING</p> <p>Powered tools can vibrate in use. Vibration, repetitive motions or uncomfortable positions may be harmful to your hands and arms. Stop using any tool if discomfort, tingling feeling or pain occurs. Seek medical advice before resuming use.</p>
-----------------------------------------------------------------------------------	-------------------------------------------------------------------------------------------------------------------------------------------------------------------------------------------------------------------------------------------------------------------------------

	<p>▲ WARNING</p> <p>INDOOR USE ONLY.</p>
-----------------------------------------------------------------------------------	-------------------------------------------------

	<p>▲ WARNING</p> <p>Always wear hearing protection when operating this tool.</p>
-----------------------------------------------------------------------------------	-----------------------------------------------------------------------------------------

	<p>▲ WARNING</p> <p>Do not carry the tool by the cord.</p>
-----------------------------------------------------------------------------------	-------------------------------------------------------------------

	<p>▲ WARNING</p> <p>The Torque Reaction Bar must be positioned against a positive stop. Do not use the Bar as a dead handle and take all precautions to make certain the operator's hand cannot be pinched between the Bar and a solid object.</p>
-----------------------------------------------------------------------------------	-----------------------------------------------------------------------------------------------------------------------------------------------------------------------------------------------------------------------------------------------------------

	<p>▲ WARNING</p> <p>Always turn off the electrical supply and disconnect the power cord before installing, removing or adjusting any accessory on this tool, or before performing any maintenance on this tool.</p>
-------------------------------------------------------------------------------------	----------------------------------------------------------------------------------------------------------------------------------------------------------------------------------------------------------------------------

	<p>▲ WARNING</p> <p>Do not use damaged, frayed or deteriorated power cords.</p>
-------------------------------------------------------------------------------------	----------------------------------------------------------------------------------------

	<p>▲ WARNING</p> <p>Keep body stance balanced and firm. Do not overreach when operating this tool.</p>
-------------------------------------------------------------------------------------	---------------------------------------------------------------------------------------------------------------

MAINTENANCE SECTION

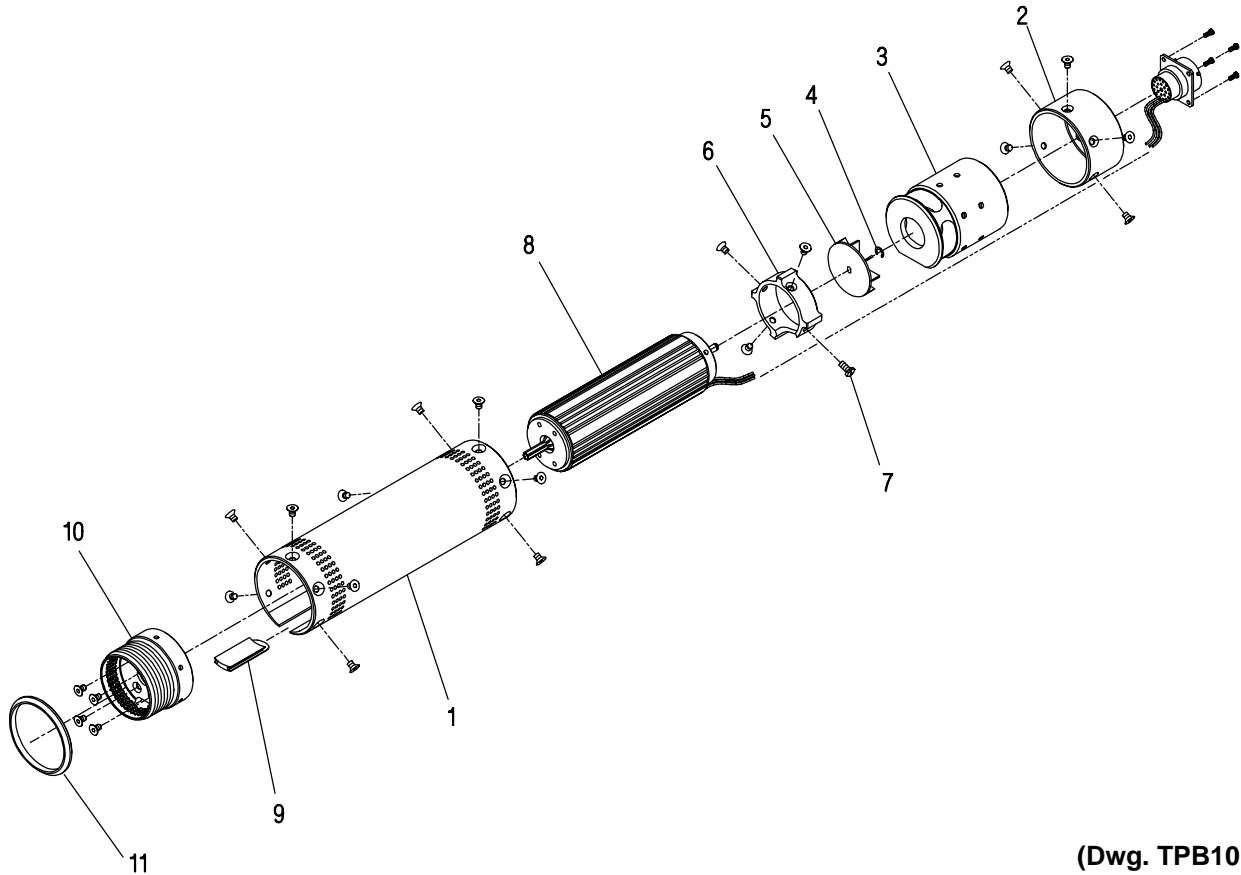

(Dwg. TPB1017)

PART NUMBER FOR ORDERING



		For DEM120	For DEF150
	Power Module	DEM120U1	DEF150U1
1	Motor Housing	DEM120-40	DEM120-40
2	End Cap	DEM120-25	DEM120-25
3	Connector Housing	DEM120-800	DEM120-800
4	Snap Ring	DEA120-797	DEA120-797
5	Fan	DEA120-62	DEA120-62
6	Rear Coupler	DEM120-796	DEM120-796
7	Grounding Screw	DEA120-800	DEA120-800
8	Motor Assembly	DEM120-A22	DEM120-A22
9	Access Cover	DEM120-749	DEM120-749
10	Front Coupler	DEM120-491	DEF150-491
11	Retaining Ring	DEM120-482	----

NOTICE

SAVE THESE INSTRUCTIONS. DO NOT DESTROY.