

**MAINTENANCE SECTION COVERING
DAA40-K364 HANGER KIT
for
SERIES DAA40 TORQUE CONTROL WRENCHES**



This symbol is to alert the user and service personnel to the presence of important operating instructions that must be read and understood to prevent personal injury, electrical shock or damage to the equipment.

▲ WARNING

When installing or removing the Hanger Kit on a tool, use a copper or leather cover on the vise jaws and **ALWAYS** hold the tool by the flats on the Gear Case or by the front of the Angle Head. **NEVER** grasp the composite tool body or handle in vise jaws. Such practice will result in damage to the tool.

NOTICE

The use of other than genuine Ingersoll-Rand replacement parts may result in decreased tool performance and increased maintenance, and may invalidate all warranties.

Ingersoll-Rand is not responsible for customer modification of tools for applications on which Ingersoll-Rand was not consulted.

Repairs should be made only by authorized, trained personnel. Consult your nearest Ingersoll-Rand Servicenter.

It is the responsibility of the employer to place the information in this manual into the hands of the person installing the kit.

HANGER KIT FOR DAA40 WRENCH

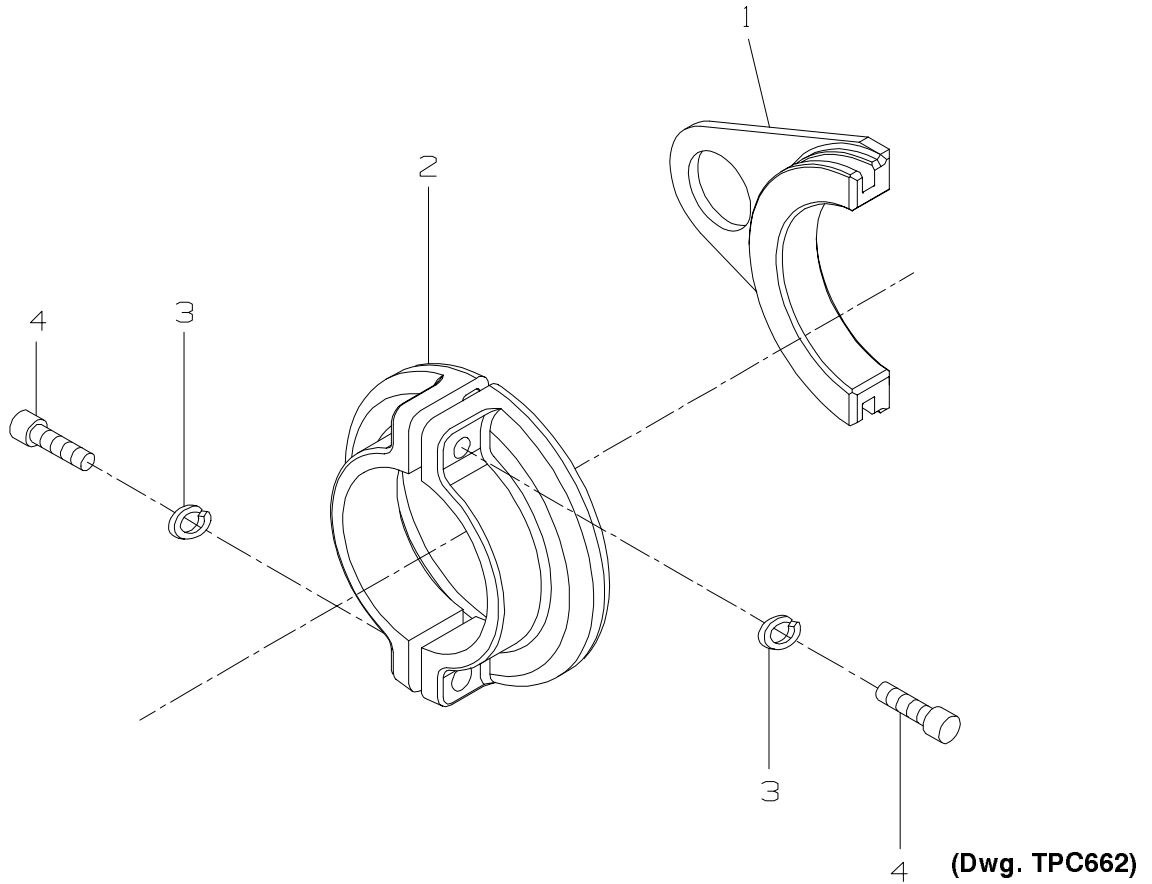

PART NUMBER FOR ORDERING →

	Hanger Kit	DAA40-K364
1	Swivel Hanger	DEA40-366
2	Clamp	DAA40-364
3	Lockwasher (2)	4U-58
4	Cap Screw (2)	SRA010A1-68

NOTICE

SAVE THESE INSTRUCTIONS. DO NOT DESTROY.