

MAINTENANCE SECTION COVERING HAND–HELD POWER MODULES for DAT40 SERIES TORQUE CONTROL AIR WRENCHES

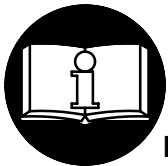

⚠ WARNING

**IMPORTANT SAFETY INFORMATION ENCLOSED.
READ THIS MANUAL BEFORE OPERATING TOOL.**

**IT IS THE RESPONSIBILITY OF THE EMPLOYER TO PLACE THE INFORMATION
IN THIS MANUAL INTO THE HANDS OF THE OPERATOR.**

FAILURE TO OBSERVE THE FOLLOWING WARNINGS COULD RESULT IN INJURY.

PLACING TOOL IN SERVICE

- Always operate, inspect and maintain this tool in accordance with all regulations (local, state, federal and country), that may apply to hand held/hand operated pneumatic tools.
- For safety, top performance, and maximum durability of parts, operate this tool at 90 psig (6.2 bar/620 kPa) maximum air pressure at the inlet with 3/8" (10 mm) inside diameter air supply hose.
- Always turn off the air supply and disconnect the air supply hose before installing, removing or adjusting any accessory on this tool, or before performing any maintenance on this tool.
- Do not use damaged, frayed or deteriorated air hoses and fittings.
- Be sure all hoses and fittings are the correct size and are tightly secured. See Dwg. TPD905–1 for a typical piping arrangement.
- Always use clean, dry air at 90 psig maximum air pressure. Dust, corrosive fumes and/or excessive moisture can ruin the motor of an air tool.
- Do not lubricate tools with flammable or volatile liquids such as kerosene, diesel or jet fuel.
- Do not remove any labels. Replace any damaged label.

USING THE TOOL

- Always wear eye protection when operating or performing maintenance on this tool.

- Always wear hearing protection when operating this tool.
- Keep hands, loose clothing and long hair away from rotating end of tool.
- Note the position of the reversing lever before operating the tool so as to be aware of the direction of rotation when operating the throttle.
- Anticipate and be alert for sudden changes in motion during start up and operation of any power tool.
- Keep body stance balanced and firm. Do not overreach when operating this tool. High reaction torques can occur at or below the recommended air pressure.
- Tool shaft may continue to rotate briefly after throttle is released.
- Air powered tools can vibrate in use. Vibration, repetitive motions or uncomfortable positions may be harmful to your hands and arms. Stop using any tool if discomfort, tingling feeling or pain occurs. Seek medical advice before resuming use.
- Use accessories recommended by Ingersoll–Rand.
- Use only impact sockets and accessories. Do not use hand (chrome) sockets or accessories.
- This tool is not designed for working in explosive atmospheres.
- This tool is not insulated against electric shock.

(Continued on page 2–2)

NOTICE

The use of other than genuine Ingersoll–Rand replacement parts may result in safety hazards, decreased tool performance, and increased maintenance, and may invalidate all warranties.

Repairs should be made only by authorized trained personnel. Consult your nearest Ingersoll–Rand Authorized Servicenter.

Refer All Communications to the Nearest
Ingersoll–Rand Office or Distributor.

© Ingersoll–Rand Company 2000

Printed in U.S.A.



⚠ WARNING

FAILURE TO OBSERVE THE FOLLOWING WARNINGS COULD RESULT IN INJURY.









USING THE TOOL (Continued)

- Do not remove the Inlet Plug without first disconnecting the live air supply.
- Whenever the Angle Head is installed or repositioned, the Throttle Lever must be positioned so that reaction torque will not tend to retain the throttle in the “ON” position.
- When installing or removing the output device on any tool, ALWAYS grasp a metal component of the tool while tightening or loosening the Coupling Nut or Spindle Cap. Acceptable clamping locations include, but are not limited to, the hex on the Gear Case, the Tool Hanger, the Torque Reaction Arm or any metal Mounting Plate. NEVER grasp the composite tool body or handle in vise jaws to restrain the torque of the Coupling Nut or Spindle Cap. Such practice will result in damage to the tool.
- Do not use power units and gear trains that exceed the capability of the output device.
- The Tube Nut Attachment has an opening on the front side for construction and application purposes. DO NOT, under any circumstance place your fingers in this opening.
- The Torque Reaction Bar must be positioned against a positive stop. Do not use the Bar as a dead handle and take all precautions to make certain the operator’s hand cannot be pinched between the Bar and a solid object.
- When operated continuously for long periods of time, Series D Nutrunners may become hot at the spindle end of the tool. Take all precautions necessary to avoid skin contact with the hot surfaces. Prolonged contact may result in burns.
- All Series D Torque Control Wrenches and Nutrunners with reverse capability have rotational arrows molded into the housing in the area of the reversing mechanism. When the direction switching device is positioned nearest the molded circular arrow with an “F” in the center, spindle rotation will be forward or clockwise direction. When the direction switching device is positioned nearest the molded circular arrow with an “R” in the center, spindle rotation will be reverse or counterclockwise direction.

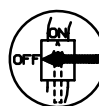
WARNING LABEL IDENTIFICATION

⚠ WARNING

FAILURE TO OBSERVE THE FOLLOWING WARNINGS COULD RESULT IN INJURY.

	⚠ WARNING Always wear eye protection when operating or performing maintenance on this tool.		⚠ WARNING Always wear hearing protection when operating this tool.		⚠ WARNING Always turn off the electrical supply and disconnect the power cord before installing, removing or adjusting any accessory on this tool, or before performing any maintenance on this tool.
	⚠ WARNING Powered tools can vibrate in use. Vibration, repetitive motions or uncomfortable positions may be harmful to your hands and arms. Stop using any tool if discomfort, tingling feeling or pain occurs. Seek medical advice before resuming use.		⚠ WARNING Do not carry the tool by the cord.		⚠ WARNING Do not use damaged, frayed or deteriorated power cords.
	⚠ WARNING The Torque Reaction Bar must be positioned against a positive stop. Do not use the Bar as a dead handle and take all precautions to make certain the operator’s hand cannot be pinched between the Bar and a solid object.		⚠ WARNING Keep body stance balanced and firm. Do not overreach when operating this tool.		

PLACING IN SERVICE

LUBRICATION

Adequate lubrication is imperative for maximum performance and durability of the gearing in these Tools.



Ingersoll–Rand No. 10 Oil

The use of an air line lubricator is recommended. For permanent installations, we recommend using an Ingersoll–Rand No. C18–03–FKG0–28 Filter–Lubricator–Regulator Unit.

If an air line lubricator is not used, inject 2 cc of the recommended oil into the air inlet before attaching the air hose and after each **eight** hours of operation.

ADJUSTMENTS

Before placing your Ingersoll–Rand Torque Control Wrench Hand–Held Power Module in service, some optional adjustments can be made to the unit which will enhance the performance of the tool or improve operator comfort. Selection and adjustments should be made prior to placing the tool in service.

CLUTCH ADJUSTMENT

To adjust the clutch on these Angle Wrenches, proceed as follows:

1. Rotate the Clutch Adjusting Hole Cover (61) until the slot in the Cover aligns with a corresponding slot in the Motor Housing Assembly (41).
2. Using a wrench on the square drive spindle or hex bit insert, rotate the output spindle until the half circle notch on the motor end of the Clutch Adjusting Nut Lock (69) is visible in the slot.
3. Insert a #1 Phillips head screwdriver into the notch of the Nut Lock and one of the notches in the Clutch Adjusting Nut (68). Insert the screwdriver far enough to create a gap between the Nut Lock and Adjusting Nut.
4. Turn the screwdriver clockwise (as you would to tighten a screw) to increase the the clutch torque or counterclockwise to decrease the clutch torque.
5. Final clutch adjustment should be set on the job.

GRIP ADJUSTMENT

The Handle (1) of the Angle Wrench has an Adjustable Grip (8) which permits individual operators to select one of three handle thickness positions. Operators with large hands can select the bulkiest position and operators with small hands can select the smallest size. To adjust the Grip, proceed as follows:

1. Grasp the grooved ends of the Adjustable Grip Latch (B), and spreading the ends slightly, raise the Latch to its uppermost position. (Refer to TPD1834).

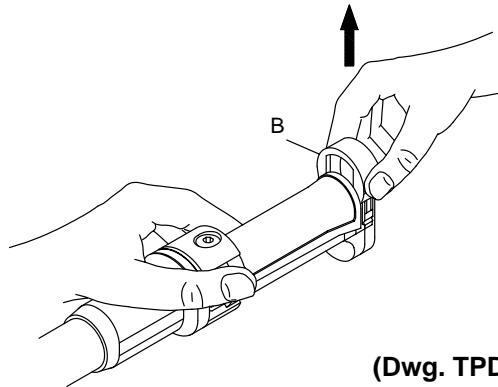

(Dwg. TPD1834)

2. Grasp the Adjustable Grip (A) and slide it rearward until it stops. (Refer to TPD1835).

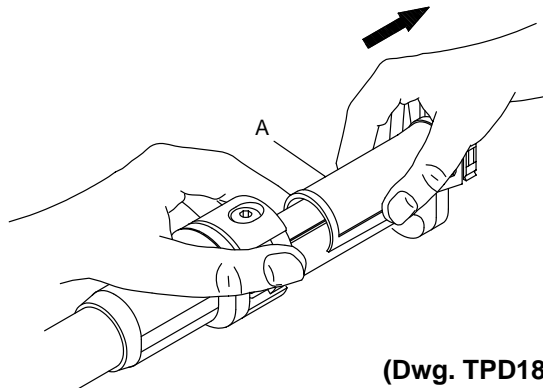

(Dwg. TPD1835)

3. Raise or lower the Grip until the desired grooves inside the Grip align with the appropriate lugs on the Handle. (Refer to TPD1836).

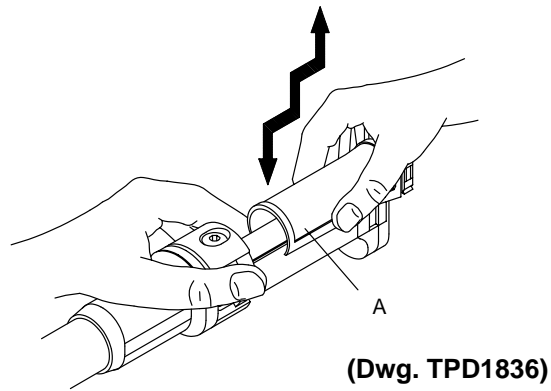

4. Slide the Grip forward onto the Handle until it butts against the Collar Assembly. (Refer to TPD1837).

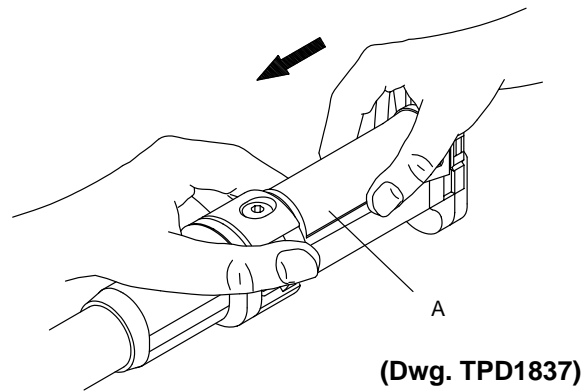

5. Push the Grip Latch downward to its original position to lock the adjustment into position. (Refer to TPD1838).

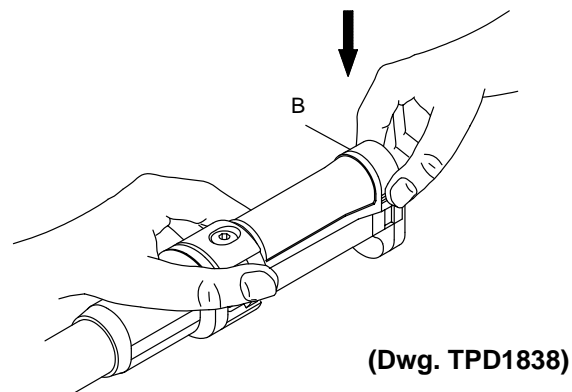

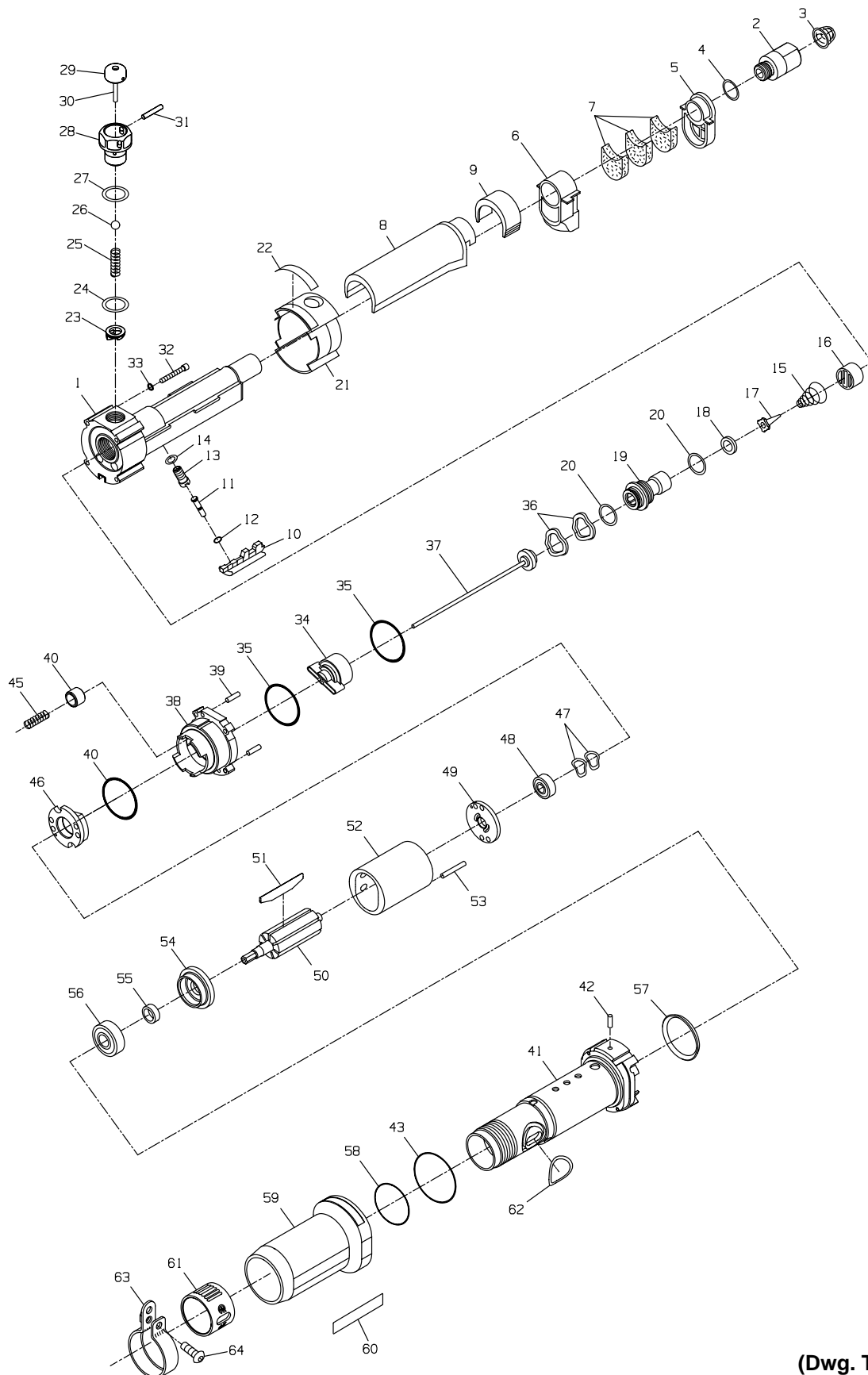

(Dwg. TPA1547)



PART NUMBER FOR ORDERING

PART NUMBER FOR ORDERING

2-7

	Handle Assembly	DAT40-A25		36	Reverse Valve Washer (2)	DAA40-191
1	Handle	DAT40-25	•	37	Shutoff Valve Assembly	DAA40-A435
2	Inlet Bushing	DAA40-565		38	Motor Clamp Spacer	DAT40-A13
•	3 Inlet Bushing Screen	5RA-61		39	Pin (2)	R4-421
•	4 Inlet Bushing Seal	DAA40-103	•	40	Motor Clamp Seal	WFS182-211
5	Exhaust Deflector	DAA40-23		41	Motor Housing Assembly	DAT40-A40
6	Muffler Body	DAA40-123		42	Housing Alignment Pin	DAA40-669
•	7 Muffler Element (3)	DAA40-311	•	43	Rear Motor Housing Seal	DAA40-610
8	Adjustable Grip	DAA40-30		44	Shuttle Valve	DAT40-5
9	Adjustable Grip Latch	DAA40-402		45	Spring	R000B-51
10	Throttle Lever	DAA40-273		46	Rear Rotor Bearing Housing	DAT40-203
11	Throttle Valve Plunger	DAA40-94		47	Rotor Bearing Spring	DG20-278
•	12 Valve Plunger Seal	WWA100-405		48	Rear Rotor Bearing	DG20-22
13	Valve Plunger Bushing	DAA40-A503		49	Rear End Plate	DAA40-12
14	Bushing Seal	8SL-259		50	Rotor	DAA40-53
•	15 Throttle Valve Spring	R4-262	•	51	Vane Packet (set of 7 vanes)	DAA40-42-7
16	Throttle Valve Guide	DAA40-91		52	Cylinder Assembly	DAA40-A3
•	17 Throttle Valve	DAA40-302		53	Cylinder Dowel	9DF5846-667
•	18 Throttle Valve Seat	DAA40-303		54	Front End Plate	DAA40-11
19	Throttle Body	DAA40-300		55	Rotor Spacer	DG10-65-5
•	20 Throttle Body Seal (2)	410-283		56	Front Rotor Bearing	LG1-24
21	Collar Assembly	DAA40-A703		57	Motor Clamp Washer	401A9-554
•	22 Warning Label	DAA40-98	•	58	Front Motor Housing Seal	WFS182-211
23	Spring Seat	DAT40-592	+	59	Housing Sleeve Assembly	DAA40-A39
•	24 Valve Seal	CE110-210	•	60	Warning Label	DAT40-99
•	25 Spring	DAT40-146		61	Clutch Adjusting Hole Cover	DAA40-415
26	Ball	DAT40-266	•	62	Adjusting Hole Cover O-Ring	R4-210
•	27 Seal	DAA40-103		63	Hanger	DAA40-A366
•	28 Valve Seat	DAT40-330		64	Hanger Screw	DAA40-638
29	Reverse Button Assembly	DAT40-A93	*		Screwdriver	DAA40-26
30	Pin	DAT40-302	*		Tune-up Kit (includes illustrated items 3, 4, 7(3), 12, 15, 17,18, 20(2), 35(2), 37, 40, 43, 44, 48, 51, 56, 62, 72(3), 73, 74, 75, 76(6), 77(3), 81, and Gear Module Components Part numbers DAA40-5 and DAA40-606)	DAA40-TK1
31	Pin	WF171-58				
•	32 Handle Mounting Screw (4)	DAA40-68				
•	33 Mounting Screw Lock Washer (4)	DAA40-58				
34	Feed Port	DAT40-329				
•	35 Reverse Valve Seal (2)	R00A2-103				

* Not illustrated.

• To keep downtime to a minimum, it is desirable to have on hand certain repair parts. We recommend that you stock one (pair or set) of each part indicated by a bullet (•) for every four tools in service.

+ To ensure proper labeling when ordering a Housing Sleeve Assembly, furnish the complete model number for the tool on which the new Sleeve Assembly will be installed.

SERIES DAT40 CLUTCH

2-8

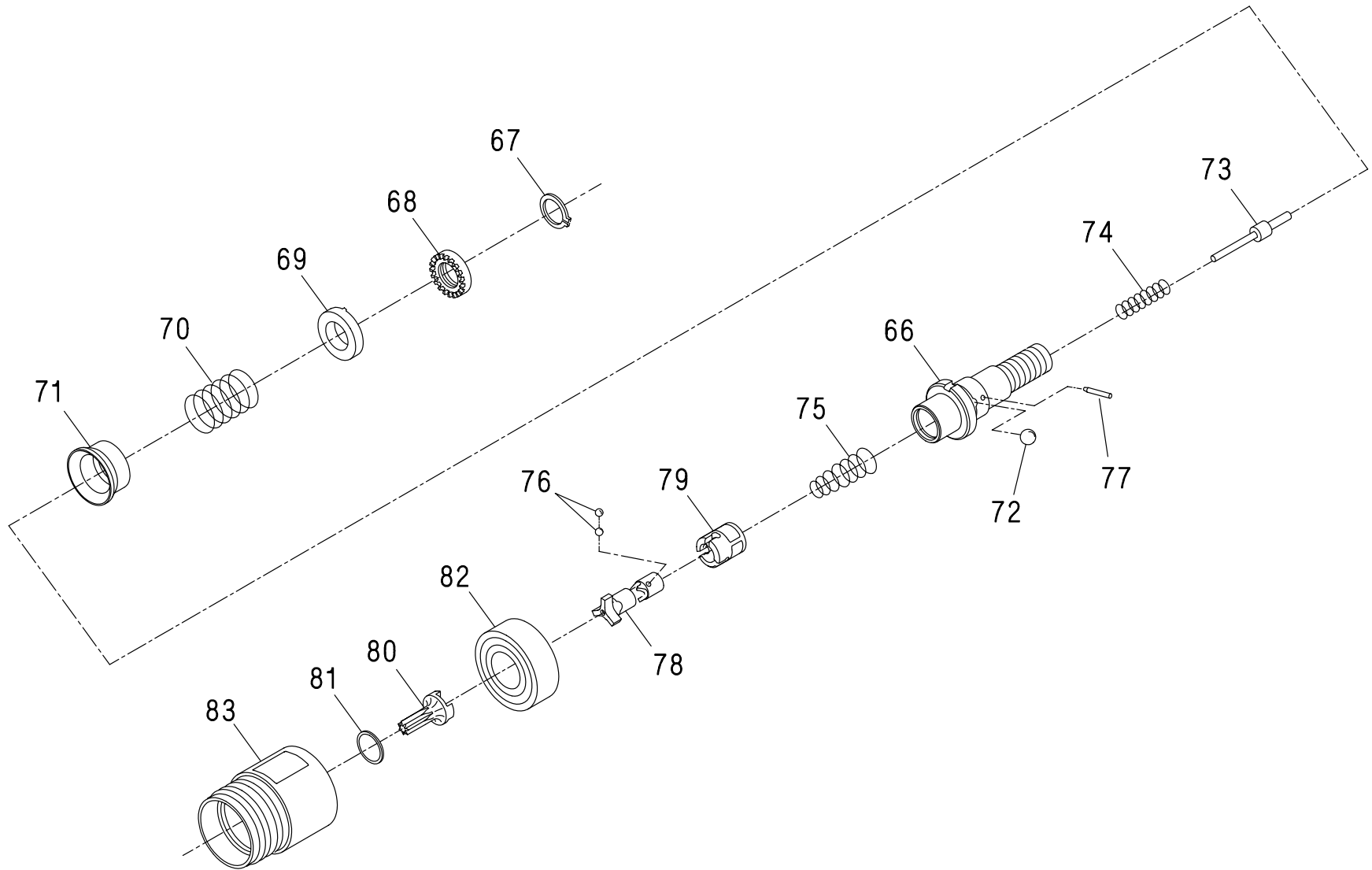

(Dwg. TPB1024)



PART NUMBER FOR ORDERING 

2-9

#	Clutch Assembly	
	for DAT Models	DAA40-A581
	for DATT Models	DAAT40-A581
66	Clutch Shaft	DAA40-581
• 67	Retainer	12E-6
68	Clutch Adjusting Nut	DAA40-582
69	Adjusting Nut Lock	DAA40-588
70	Clutch Spring	DAA40-583
71	Cam Follower	DAA40-406
• 72	Clutch Ball (3)	2U-722
• 73	Shutoff Spool	DAA40-900
• 74	Valve Return Spring	DAA40-842
• 75	Reset Spring	DAA40-627
• 76	Shutoff Ball (6)	DAA40-629
• 77	Cam Pin (3)	DAA40-704
78	Cam Shaft	DAA40-502
79	Cam Block	DAA40-721
80	Clutch Spindle	
	for DAT Models	DAA40-584
	for DATT Models	DAMT40-584
• 81	Spindle Retainer	7L1B-28
82	Clutch Bearing	R1602-510
83	Clutch Housing	DAA40-580

- # When replacing the Clutch Assembly or any clutch components, check the gap of the Shutoff Valve Assembly as instructed on page 2-13 and, if necessary, adjust the gap as instructed.
- To keep downtime to a minimum, it is desirable to have on hand certain repair parts. We recommend that you stock one (pair or set) of each part indicated by a bullet (•) for every four tools in service.

MAINTENANCE SECTION



Always turn off the air supply and disconnect the air supply hose before installing, removing or adjusting any accessory on this tool, or before performing any maintenance on this tool. Failure to do so could result in injury.

Always use protective eyewear when performing maintenance on a tool or operating a tool.

DISASSEMBLY

Disassembly of the Clutch

1. Carefully grasp the Housing Sleeve Assembly (59) with the clutch end upward, and using a wrench on the flats of the Clutch Housing (83), unscrew and remove the Clutch Housing.
2. Grasp the Clutch Spindle (80) and pull the assembled clutch off the Rotor (50).
3. Remove the Shutoff Spool (73) and Valve Return Spring (74) from either the shaft of the Rotor or the inside of the Clutch Shaft (66).
4. Insert the jaws of snap ring pliers into the holes of the Retainer (67) and expand the Retainer only enough to release the pressure against the Clutch Shaft. While keeping the pressure relieved, unscrew the assembled clutch from the Retainer as you would unscrew a nut from a bolt. Expanding the Retainer sufficiently to clear the Shaft in a normal manner will distort the snap ring beyond acceptable limits.
5. Insert the tip of a #1 Phillips head screwdriver into the notch in the motor end of the Adjusting Nut Lock (69) and one of the notches in the Clutch Adjusting Nut (68) and turn the screwdriver counterclockwise (as you would to remove a screw) to back the Nut off the Clutch Shaft. Insert the screwdriver far enough to create a gap between the Nut Lock and Adjusting Nut.
6. Remove the Nut Lock, Clutch Spring (70), Cam Follower (71) and three Clutch Balls (72) from the Clutch Shaft.
7. Pull the Clutch Bearing (82) off the spindle end of the Clutch Shaft.
8. To remove the three Cam Pins (77), position one pin downward and sharply rap the motor end of the Clutch Shaft on a workbench mat or a piece of corrugated cardboard box. Repeat the process for each of the remaining two Pins.
9. Using a thin blade screwdriver, spiral the Spindle Retainer (81) out of the groove in the Clutch Shaft and pull the Clutch Spindle from the Shaft.
10. Pull the Cam Shaft (78), Cam Block (79) and Reset Spring (75) from the Clutch Shaft.
11. To remove the six Shutoff Balls (76), insert the shaft of the Shutoff Spool into the end of the Cam Shaft to prevent the Balls from becoming lodged in the central

opening. Position one of the shutoff ball openings downward and sharply rap the Cam Shaft on a workbench mat or a piece of corrugated cardboard box. Two Shutoff Balls are installed in each hole. Repeat the process at the other two locations for the remaining four Balls.

Disassembly of the Motor

1. Move the Adjustable Grip (8) to the lowest position on the Handle (1).
2. Using a 2-1/2 mm hex wrench, unscrew and remove the four Handle Mounting Screws (32) with the Mounting Screw Lock Washers (33).
3. Pull the assembled motor away from the Handle.
4. Pull the Clutch Adjusting Hole Cover (61) and the Housing Sleeve Assembly (59) off the Motor Housing (41). Remove the Adjusting Hole Cover O-ring (62), the Front Motor Housing Seal (58) and Rear Motor Housing Seal (43) from the Motor Housing Assembly.
5. Remove the Feed Port (34), two Reverse Valve Seals (35), Shutoff Valve Assembly (37), Motor Clamp Spacer (38), Shuttle Valve (44), Spring (45), and the Motor Clamp Seal (40) from the Motor Housing Assembly.
6. Lightly rap the handle end of the Motor Housing on a padded surface to dislodge the assembled motor from the Housing.
7. Remove the Motor Clamp Washer (57) from the Housing or front of the assembled motor.
8. Grasping the Front End Plate (54) in one hand, tap the spline shaft end of the Rotor (50) with a plastic hammer to remove the Front End Plate, Front Rotor Bearing (56) and Rotor Spacer (55) from the Rotor.
9. Slide the Cylinder Assembly (52) off the Rotor and remove the seven Vanes (51).
10. Remove the Rear Rotor Bearing Housing (46) and two Rotor Bearing Springs (47) from the handle end of the Rotor.
11. Press the Rear Rotor Bearing (48) along with the Rear End Plate (49) from the shaft of the Rotor.

Disassembly of the Handle

1. Remove the two Reverse Valve Washers (36) from the hub of the Throttle Body (19).
2. Insert a 5/16" hex wrench into the end of the Throttle Body and unscrew it from the Handle (1).
3. Remove the two Throttle Body Seals (20), Throttle Valve Seat (18), Throttle Valve (17), Throttle Valve Spring (15) and Throttle Valve Guide (16).
4. Using an adjustable wrench, unscrew and remove the Valve Seat (28). Turn the tool upside down to allow the Seal (27), Ball (26), Spring (25), Spring Seal (24) and Spring Seat (23) to drop out. The Pin (31) may now be removed to separate the Valve Seat from the Reverse Button Assembly (29), if desired.

MAINTENANCE SECTION

- Depress the Throttle Lever Plunger (11) and slide the Collar Assembly (21) rearward until it clears the Lever.
- Remove the Throttle Lever from the Handle.
- Using a screwdriver, unscrew and remove the Valve Plunger Bushing (13) and Bushing Seal (14) along with the Throttle Valve Plunger (11) and Valve Plunger Seal (12).
- Pull the Throttle Valve Guide (16) from the motor end of the Handle.
- Using an adjustable wrench, unscrew and remove the Inlet Bushing (2) and Seal (4) from the end of the Handle. Remove the Inlet Bushing Screen (3) from the Inlet Bushing.
- Pull the Exhaust Deflector (5), Muffler Body (6) and three Muffler Elements (7) off the end of the Handle.
- Raise the Adjustable Grip Latch (9) to the highest position, spread the open end slightly and slide the Latch off the rear of the Handle.
- Slide the Adjustable Grip (8) and Collar Assembly (21) off the rear of the Handle.
- Install the Throttle Valve Spring, large end leading, in the handle against the Throttle Valve Guide.
- Install the two Reverse Valve Washers (36) on the hub with the internal hex in the Throttle Body (19) and secure it by installing one of the Throttle Body Seals (20) in the annular groove ahead of it. Install the other Seal in the annular groove on the other side of the large hub.
- Position the Throttle Valve Seat (18) and Throttle Valve (17) in the central opening of the Throttle Body opposite the internal hex and carefully slide the assembly into the motor end of the Handle.
- Using a 5/16" hex wrench, tighten the Throttle Body between 30 and 40 in-lb (3.4 and 4.5 Nm) torque.
- With the Collar Assembly (21) toward the muffler end of the Handle, position the Throttle Lever (10) in the Handle with the rounded projection at one end of the Lever entering the corresponding rounded notch in the Handle. Depress the Lever and slide the Collar Assembly forward toward the motor end of the Handle to capture and retain the Lever.
- Slide the Inlet Bushing Seal (4) over the threads of the Inlet Bushing (2) and install it in the end of the Handle. Tighten the Bushing between 25 and 30 ft-lb (34 and 40 Nm) torque.
- Insert and properly position the Spring Seat (23) in the Motor Housing (41). Set the large end of Spring (25) on the Spring Seat and set Ball (26) on the small end of the Spring. Set the Reverse Button Assembly (29) into the Valve Seat (28) and insert Pin (31) thru the Valve Seat and Button to tie them together. Slide The Seal (27) Pin (31) thru the Valve Seat and Button to tie them together. Slide The Seal (27) past the threads and position it against the shoulder of the Valve Seat. Screw the Valve Seat into the Handle and tighten between 85 and 100 in-lb (9.6 and 11.3 Nm) torque.

ASSEMBLY

Assembly of the Handle

- Slide the Collar Assembly (21) onto the Handle (1).
- Install the Muffler Body (6), large opening trailing, onto the inlet end of the Handle.
- Position the three Muffler Elements (7) into the Muffler Body and then capture them by installing the Exhaust Deflector (5) against the Muffler Body.
- Install the Inlet Bushing Seal (4) over the threads of the Inlet Bushing (2) and install it in the end of the Handle. Tighten the Bushing between 20 and 30 ft-lb (27 and 40 Nm) torque.
- Push the Throttle Valve Guide (16), open end leading, into the recess at the motor end of the Handle. Rotate the Guide until the hole in the side of the Guide aligns with the opening for the Throttle Valve Plunger (11).
- With the Valve Plunger Seal (12) installed in the annular groove in the Throttle Valve Plunger, slide the Plunger, large end trailing, into the non-slotted end of the Valve Plunger Bushing (13).
- Install the Bushing Seal (14) over the threads of the Bushing against the large head.
- Apply Perma-Lok LH050 Pipe Sealant* to the first two threads of the slotted end of the Bushing.
- Using a screwdriver in the slot of the Bushing, thread the assembled Plunger and Bushing into the Handle until the trailing end of the Bushing is flush with the handle surface. Make certain the Plunger enters the hole in the Throttle Valve Guide. Make certain the Plunger is retracted against the Bushing before installing the Throttle Valve Spring (15).

* Product of National Starch and Chemical Corporation.

Assembly of the Motor

- Place the Rear End Plate (49), face with the kidney shaped slots leading, onto the unstained hub of the Rotor (50). Position the Rear Rotor Bearing (48) on the same hub and press the Bearing onto the shaft against the Rear End Plate.
- Install the Cylinder (52) over the Rotor so that the Cylinder Dowel (53) enters the hole in the Rear End Plate.
- Apply a thin film of oil to each Vane (51) and insert a Vane into each of the rotor vane slots.
- Place the Rotor Spacer (55) on the splined hub of the Rotor and install the Front End Plate (54) over the Spacer, counterbored end trailing, against the rotor face.

MAINTENANCE SECTION

5. Press the Front Rotor Bearing (56) onto the hub and into the Front End Plate.

NOTICE

The Clutch Assembly must be assembled with the motor before attaching them to the Handle. If the Clutch is not assembled, set the motor aside and assemble the clutch as instructed in the section, ASSEMBLY OF THE CLUTCH.

Assembly of the Clutch

1. Install two Shutoff Balls (76) into each of the three holes located radially in the Cam Shaft (78) and then slide the assembly into the Cam Block (79). Fill the Cam Shaft with grease to retain the Balls.
2. Press the Clutch Bearing (82) onto the spindle end of the Clutch Shaft.
3. Install the Reset Spring (75), tapered end leading, onto the small hub of the Cam Shaft and insert the assembled parts, Spring first, into the central opening at the non-threaded end of the Clutch Shaft (66).
4. Apply pressure to the assembly to keep it in the Shaft and install the three Cam Pins (77) into the radial holes in the Clutch Shaft and into the slots of the Cam Shaft to capture the assembly.
5. Position the Clutch Spindle (80) in the bearing end of the Clutch Shaft and secure it by using a thin blade screwdriver to spiral the Spindle Retainer (81) into the groove inside the Clutch Shaft.
6. Apply grease to the three Clutch Balls (72) and install them in the holes in the Clutch Shaft near the large flange. Slide the Cam Follower (71), large end first, onto the threaded end of the Clutch Shaft and pull it forward to capture the Balls between the flange and the Follower.
7. Slide the Clutch Spring (70) and the Clutch Adjusting Nut Lock (69), notched face trailing, onto the threaded end of the Clutch Shaft.
8. Secure the components by threading the Clutch Adjusting Nut (68), notched face leading, onto the Clutch Shaft. Insert a #1 Phillips head screwdriver into the notch of the Nut Lock and one of the notches in the Nut. Insert the screwdriver far enough to create a gap between the Nut Lock and Adjusting Nut. Turn the screwdriver clockwise as you would to tighten a screw to move the Nut along the Shaft until it clears the groove for the Retainer (67).
9. Insert the jaws of snap ring pliers into the holes of the Retainer and expand the Retainer only enough to release any pressure against the Clutch Shaft. While keeping the pressure relieved, screw the assembled clutch onto the Retainer, as you would screw a nut onto a bolt, until the Retainer enters the groove. Expanding the Retainer sufficiently to clear the Shaft in a normal manner will distort the Snap Ring beyond acceptable limits.
10. Install the Rear Motor Housing Seal (42), Front Motor Housing Seal (55) and Hole Cover O-ring (59) in the grooves in the Motor Housing (40).
11. Slide the Housing Sleeve Assembly (56), large end first, onto the Motor Housing. Slide the the Clutch Adjusting Hole Cover (58) onto the Motor Housing against the Sleeve Assembly.
12. Insert the assembled clutch, Spindle first, into the Clutch Housing (83).
13. Thread the assembled clutch and Housing onto the Motor Housing and tighten the joint between 20 and 25 ft-lb (27 and 35 Nm) torque.

CAUTION

When assembling the Gear Case with the Clutch Housing, make certain the spline of the Clutch Spindle properly engages the Drive Coupling, Rotor Pinion or Planet Gears. Improper engagement will damage the splines and may force the Clutch rearward causing the Shutoff Valve Assembly to move out of correct adjustment.

Assembling the Motor to the Handle

1. Drop the Motor Clamp Washer (54), concave side first, into the motor bore of the Motor Housing (40).
2. Apply some grease to the Shutoff Spool (73) and Valve Return Spring (74). Install the Spring on the long stem of the Spool and insert the short stem of the assembly into the hole in the splined end of the Rotor (47).
3. Hold the Motor Housing horizontally and slide the assembled motor into the Housing. Make certain the rotor spline engages the internal spline of the Clutch Shaft (66).
4. Install the two Rotor Bearing Springs (44) in the recess of the Rear Rotor Bearing Housing (43) and place both in position against the Bearing. Make sure that the Cylinder Dowel (50) enters the dowel hole in the Bearing Housing.
5. Install the Motor Clamp Seal (39) on the small hub of the Motor Clamp Spacer (38).
6. Position the Spacer in the Housing, small hub leading, so that the slots of the Spacer engage the flat on the Bearing Housing. While pushing the Spacer toward the motor, rotate the assembly until the alignment notch in the Spacer aligns with the pin in the Housing and the entire assembly moves forward.

NOTICE

It may be necessary to insert a wooden or metal block into the exposed notches of the Motor Clamp Spacer to rotate the assembly, if the assembled motor is a tight fit in the Motor Housing.

MAINTENANCE SECTION

7. The distance between the large end of the Motor Housing and the top surface of the large flange of the Shutoff Valve Assembly is critical for efficient operation. The gap must be between .258" and .264" (6.55 mm and 6.70 mm) wide. (See Dwg. TPD1251).

NOTICE

If the Clutch Housing or any clutch components have been replaced, the Shutoff Valve Assembly will require adjustment.

To determine if the gap is correct, insert the Shutoff Valve Assembly (37), shaft first, into the central opening of the motor assembly and measure the distance with a depth micrometer.

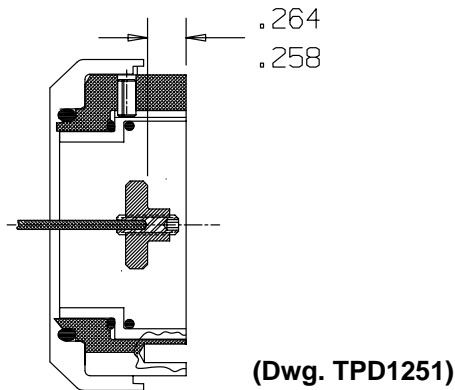

If the gap is incorrect, proceed as follows:

- a. Remove the Valve Assembly from the motor.

- b. Place a wrench on the square of the valve.
- c. Insert a hex wrench into the end of the shaft and turn it clockwise to shorten the gap or counter clockwise to increase the gap.
- d. Install the Valve Assembly and remeasure the gap. Repeat the process until the distance is correct.
8. When the gap is correct, remove the Valve Assembly from the motor.
9. Install a Reverse Valve Seal (35) into the groove on the rear end of the Feed Port (34).
10. Insert the shaft of the Shutoff Valve Assembly through the central opening of the Feed Port from the large open end.
11. Insert the Feed Port, large open end leading, along with the Shutoff Valve Assembly into the Handle. The Seal will hold the parts in position against the Handle.
12. Install the remaining Seal in the large opening of the Motor Clamp Spacer (38).
13. Insert the shaft of the Shutoff Valve Assembly into the central hole through the motor and position the assembled handle against the assembled motor.
14. Install the four Handle Mounting Screws (32) and Lock Washers (33) and tighten the Screws between 12 and 18 in-lb (1.4 and 2.0 Nm) torque.
15. Slide the Adjustable Grip (8) onto the Handle.
16. Spread the open end of the Adjustable Grip Latch (9) slightly and install it on the Handle to capture the Grip.

MAINTENANCE SECTION

TROUBLESHOOTING GUIDE

Trouble	Probable Cause	Solution
Low power or low free speed	Low air pressure at the inlet	Check air supply. For top performance, the air pressure must be 90 psig (6.2 bar/620 kPa) at the inlet.
	Plugged Inlet Bushing Screen	Clean the Inlet Bushing Screen in a clean, suitable cleaning solution. If the Screen cannot be cleaned, replace it.
	Clogged Muffler	Clean the Muffler Elements in a clean, suitable cleaning solution. If they cannot be cleaned, replace them.
	Worn or broken Vanes	Install a complete set of new Vanes.
	Worn or broken Cylinder	Replace the Cylinder if it is cracked or if the bore appears wavy or scored.
	Improper lubrication or dirt buildup	Clean and lubricate the motor unit parts.
	Incorrect gap in Shutoff Valve Assembly	Adjust the gap as explained in the section ASSEMBLING THE MOTOR TO THE HANDLE .
Leaky Throttle Valve	Worn Throttle Valve and/or Throttle Valve Seat.	Install a new Throttle Valve and/or Throttle Valve Seat.
	Dirt accumulation on Throttle Valve and/or Throttle Valve Seat	Pour about 3 cc of a clean, suitable, cleaning solution into the air inlet and operate the tool for about 30 seconds. Immediately , pour 3 cc of light oil into the tool and operate the tool for 30 seconds to lubricate all the parts.
Tool fails to shut off	Dirty Shutoff Valve Assembly	Clean any dirt from the Shutoff Valve.
	Bent stem on Shutoff Valve	Straighten the stem of the Valve or replace the Valve.
	Valve out of adjustment	Adjust the Valve to get the required gap specified on Page 2-13.

NOTICE

SAVE THESE INSTRUCTIONS. DO NOT DESTROY.

NOTES