

OPERATION AND MAINTENANCE MANUAL FOR SERIES EL, EP AND ET 34V DC ELECTRIC SCREWDRIVERS

NOTICE

Series EL, EP and ET Electric Screwdrivers are designed for installing threaded fasteners in light industrial and appliance manufacturing applications. Ingersoll-Rand is not responsible for customer modification of tools for applications on which Ingersoll-Rand was not consulted.

⚠ WARNING

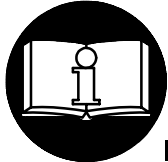

**IMPORTANT SAFETY INFORMATION ENCLOSED.
READ ALL THESE INSTRUCTIONS BEFORE PLACING TOOL IN SERVICE OR OPERATING THIS TOOL AND SAVE THESE INSTRUCTIONS.
IT IS THE RESPONSIBILITY OF THE EMPLOYER TO PLACE THE INFORMATION IN THIS MANUAL INTO THE HANDS OF THE OPERATOR.
FAILURE TO OBSERVE THE FOLLOWING WARNINGS COULD RESULT IN INJURY.
WHEN USING ELECTRIC TOOLS, BASIC SAFETY PRECAUTIONS SHOULD ALWAYS BE FOLLOWED TO REDUCE THE RISK OF FIRE, ELECTRIC SHOCK AND PERSONAL INJURY, INCLUDING THE FOLLOWING.**

PLACING TOOL IN SERVICE

- Use only with Series EC34E or EC34U Controllers.
- Always operate, inspect and maintain this tool in accordance with all regulations (local, state, federal and country), that may apply to hand held/hand operated electric tools.
- Inspect tool cords periodically and if damaged, have them repaired by an authorized service facility. Inspect extension cords periodically and replace if damaged.
- Do not remove any labels. Replace any damaged label.

USING THE TOOL

- Do not operate this tool unless the Retainer Coupling (1) and Flange (2) are installed securely.
- Always wear eye protection when operating or performing maintenance on this tool.
- Power tools can vibrate in use. Vibration, repetitive motions, or uncomfortable positions may be harmful to your hands and arms. Stop using any tool if discomfort, tingling feeling or pain occurs. Seek medical advice before resuming use.
- **Guard Against Electric Shock.** Prevent body contact with earthed or grounded surfaces. For example; pipes, radiators, ranges, refrigerator enclosures.

- **Don't abuse Cord.** Never carry tool by cord or yank it to disconnect from receptacle. Keep cord from heat, oil, and sharp edges.
- **Keep work area clean.** Cluttered areas and benches invite injuries.
- **Consider work area environment.** Don't expose power tools and chargers to water. Keep work area well lighted. Do not use tool in explosive or flammable atmospheres.
- **Keep bystanders and children away.** Do not permit unauthorized personnel to operate this tool, or touch tool or cord.
- **Store idle tools.** When not in use, tools should be stored in a dry, high or locked up place, out of reach of children.
- **Don't force tool.** It will do the job better and more safely at the rate for which it was intended.
- **Use the right tool.** Do not force a small tool or attachment to do the job of a heavy-duty tool.
- **Do not use a tool for a purpose for which it is not intended.** Example: Do not use a screwdriver as a drill.
- **Dress properly.** Do not wear loose clothing or jewelry. They can be caught in moving parts. Rubber gloves and non-skid footwear are recommended when working outdoors. Wear protective hair covering to contain long hair.

NOTICE

The use of other than genuine Ingersoll-Rand replacement parts may result in personal injury, decreased tool performance and increased maintenance, and may invalidate all warranties.

Have your tool repaired by a qualified person. This electric tool is in accordance with the relevant safety requirements. Repairs should only be carried out by qualified persons using original spare parts, otherwise this may result in considerable danger to the user.

Repairs should be made only by authorized, trained personnel. Consult your nearest Ingersoll-Rand Authorized Servicenter.

INGERSOLL-RAND®
PROFESSIONAL TOOLS

⚠ WARNING

FAILURE TO OBSERVE THE FOLLOWING WARNINGS COULD RESULT IN INJURY.

USING THE TOOL (Continued)

- **Secure work.** Use clamps or a vise to hold work. Operators often need both hands to perform job functions.
- **Don't overreach.** Keep proper footing, balance, and a firm grip on the tool at all times.
- **Maintain tools with care.** Keep tools clean for better and safer performance. Follow instructions for lubricating and changing accessories. Inspect tool cords periodically and if damaged, have them repaired by an authorized service facility. Inspect extension cords periodically and replace if damaged. Keep handles dry, clean, and free from oil and grease.
- **Remove adjusting keys and wrenches.** Form habit of checking to see that keys and adjusting wrenches are removed from tool before turning it on.
- **Avoid unintentional starting.** Don't carry tool with finger on switch.
- **Do not drop or abuse the tool.**
- **Whenever a tool is not being used, position the Power Switch to the "OFF" position and unplug the power cord.**
- **Stay alert.** Watch what you are doing. Use common sense. Do not operate tool when you are tired.
- **Check damaged parts.** Before further use of the tool, a guard or other part that is damaged should be carefully checked to determine that it will operate properly and perform its intended function. Check for alignment of moving parts, binding of moving parts, breakage of parts, mounting, and any other conditions that may affect its operation. A guard or other part that is damaged should be properly repaired or replaced by an authorized service center unless otherwise indicated elsewhere in this operation manual.
- **Have defective switches replaced by an authorized service center.**
- **Do not use the tool if the switch does not turn it on and off.**
- **Do not drop or abuse the screwdriver.**
- **Whenever changing a bit, make certain the Forward/Reverse Switch is in the "OFF" position and the tool is unplugged.**
- **Do not allow chemicals such as acetone, benzene, thinner, ketone, trichloroethylene or other similar chemicals to come in contact with the screwdriver housing as damage will result.**
- **Do not adjust the torque setting higher than 5 on the Torque Scale.**
 Duty cycle: 1200 rpm and 2000 rpm models -
 MAX 0.5 sec. "ON"
 MIN 3.5 sec. "OFF"
 all other models -
 MAX 0.8 sec. "ON"
 MIN 3.5 sec. "OFF"
- **Do not tighten more than 900 tapping screws (size: 2 mm, length: 4 mm) per hour.**
- **Do not operate the Forward/Reverse Switch when the motor is running.**
- **Whenever a tool is not being used, move the Forward/Reverse Switch to the "OFF" position and unplug the screwdriver.**
- **The use of any accessory or attachment other than recommended in this manual can present a risk of personal injury.**

WARNING LABEL IDENTIFICATION

	⚠ WARNING Always wear eye protection when operating or performing maintenance on this tool.
---	---

	⚠ WARNING Always wear hearing protection when operating this tool.
---	--

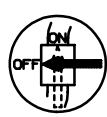
	⚠ WARNING Always turn off the electrical supply and disconnect the power cord before installing, removing or adjusting any accessory on this tool, or before performing any maintenance on this tool.
---	---

	⚠ WARNING Powered tools can vibrate in use. Vibration, repetitive motions or uncomfortable positions may be harmful to your hands and arms. Stop using any tool if discomfort, tingling feeling or pain occurs. Seek medical advice before resuming use.
---	--

	⚠ WARNING Do not carry the tool by the cord.
---	--

	⚠ WARNING Do not use damaged, frayed or deteriorated power cords.
---	---

	⚠ WARNING Keep body stance balanced and firm. Do not overreach when operating this tool.
---	--

ADJUSTMENTS

TORQUE ADJUSTMENT

To adjust the torque on these screwdrivers, proceed as follows:

1. Determine the torque output of the tool by checking a tightened fastener with a torque wrench.
2. Increase or decrease the torque output by rotating the Spring Adjusting Ring (4). Rotating the Ring **clockwise** to a higher number on the Torque Scale increases torque output while rotating the Ring **counterclockwise** to a lower number decreases the torque output.

NOTICE

The numbers from one to five on the Torque Scale are reference numbers only and are not an indication of actual torque output.

3. Check the adjustment with a torque wrench. A number of factors will affect torque output from one job to another. Final torque adjustment should be made at the job through a series of gradual increases. Always start below the desired torque and work upward.

DO NOT ATTEMPT TO REPAIR THIS TOOL.

All repairs and maintenance of this tool and its cord must be performed by an authorized service center. Contact Sales Office listed on last page of this form.

NOTICE

SAVE THESE INSTRUCTIONS. DO NOT DESTROY.

MODEL IDENTIFICATION

High Torque

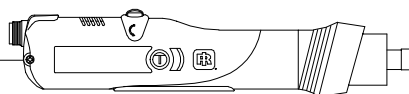

- Power: 34V DC
- Cable Length: 8 ft. Straight
- Sound: 69 dBA
- Reversible: Yes

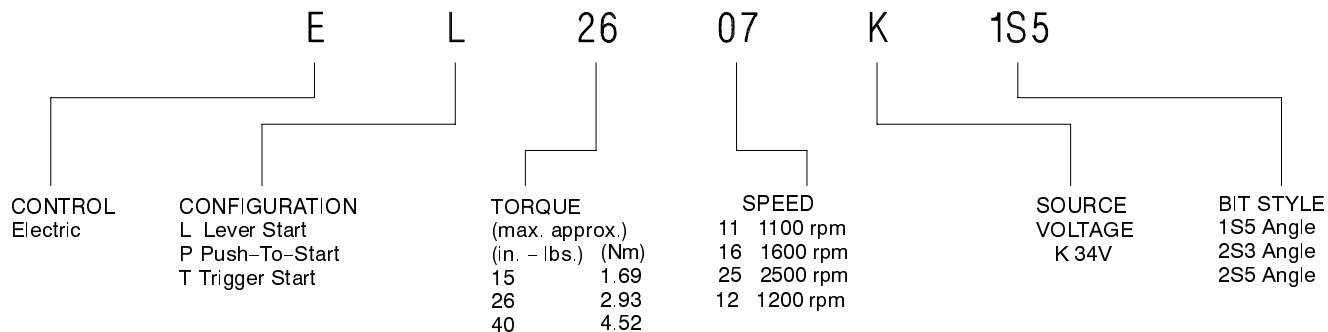

(Dwg. TPD1832)

K SERIES

Model	Volts (Direct Current)	Revolutions Per Minute	Torque Range,		Weight		Length		Drive Size inches	■ Sound Pressure Level dB(A)	◆ Vibration Level m/s ²
			in. lbs	Nm	lbs	kg	in.	mm			
EP1512K	34 V	1200 min ⁻¹	5-15	0.56-1.69	1.5	0.68	11.25	285.75	.25 HEX	70.7	1.1
EP1525K	34 V	2500 min ⁻¹	5-15	0.56-1.69	1.5	0.68	11.25	285.75	.25 HEX	70.7	1.1
EP2616K	34 V	1600 min ⁻¹	11-26	1.24-2.93	1.5	0.68	11.25	285.75	.25 HEX	70.7	1.1
EP4011K	34 V	1100 min ⁻¹	18-40	2.03-4.52	1.7	0.77	11.25	285.75	.25 HEX	70.7	1.1
EL1512K	34 V	1200 min ⁻¹	5-15	0.56-1.69	1.5	0.68	11.25	285.75	.25 HEX	70.7	1.1
EL1525K	34 V	2500 min ⁻¹	5-15	0.56-1.69	1.5	0.68	11.25	285.75	.25 HEX	70.7	1.1
EL2616K	34 V	1600 min ⁻¹	11-26	1.24-2.93	1.5	0.68	11.25	285.75	.25 HEX	70.7	1.1
ET4011K	34 V	1100 min ⁻¹	18-40	2.03-4.52	1.7	0.77	11.25	285.75	.25 HEX	70.7	1.1
EL1525K1S5	34 V	2400 min ⁻¹	4-17	0.45-1.92	1.9	0.86	17.45	443.23	1/4 SQ.	70.7	1.1
EL1525K2S3	34 V	1600 min ⁻¹	6-23	0.67-2.59	2.1	0.95	17.64	448.05	.25 HEX	70.7	1.1
EL1525K2S5	34 V	1600 min ⁻¹	6-23	0.67-2.59	2.1	0.95	17.64	448.05	1/4 SQ.	70.7	1.1
ET4011K2S3	34 V	700 min ⁻¹	15-56	1.69-6.49	2.1	0.95	17.64	448.05	.25 HEX	70.7	1.1
ET4011K2S5	34 V	700 min ⁻¹	15-56	1.69-6.49	2.1	0.95	17.64	448.05	1/4 SQ.	70.7	1.1

- Tested in accordance with ANSI S5.1-1971 at free speed.
- ◆ Tested in accordance to ISO8662-1 at free speed.

SPECIFICATIONS

DECLARATION OF CONFORMITY

We Ingersoll-Rand, Co.
(supplier's name)

Swan Lane, Hindley Green, Wigan WN2 4EZ
(address)

declare under our sole responsibility that the product,

Series EL, EP and ET 34 Volt Electric Screwdrivers

to which this declaration relates, is in compliance with the provisions of
89/336/EEC, 89/392/EEC, 73/23/EEC, 91/368/EEC,
92/31/EEC, 93/44/EEC, 93/68/EEC Directives.

By using the following Principle Standards: EN292, ISO8662, PN8NTC1.2,
EN50144-1, EN50082-1 and EN55014

Serial No. Range: (1995 →) 3VH XXXXX →

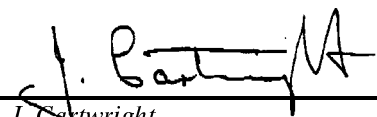
J. Cartwright
Name and signature of authorised persons

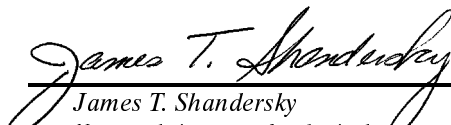
James T. Shandersky
Name and signature of authorised persons

February, 1997
Date

February, 1997
Date

NOTICE

SAVE THESE INSTRUCTIONS. DO NOT DESTROY.

When the life of the tool has expired, it is recommended that the tool be disassembled, degreased and parts be separated by material so that they can be recycled.

MAINTENANCE SECTION

Dimensions for Series EL/EP/ET Electric Screwdrivers

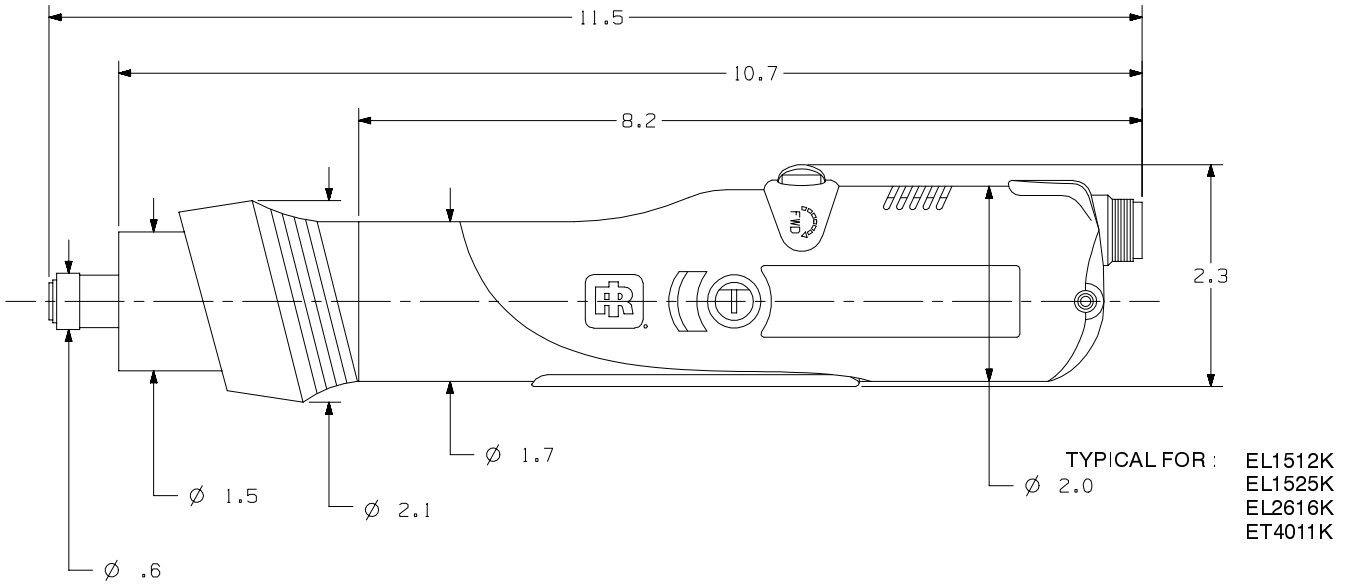

(Dwg. TPC638)

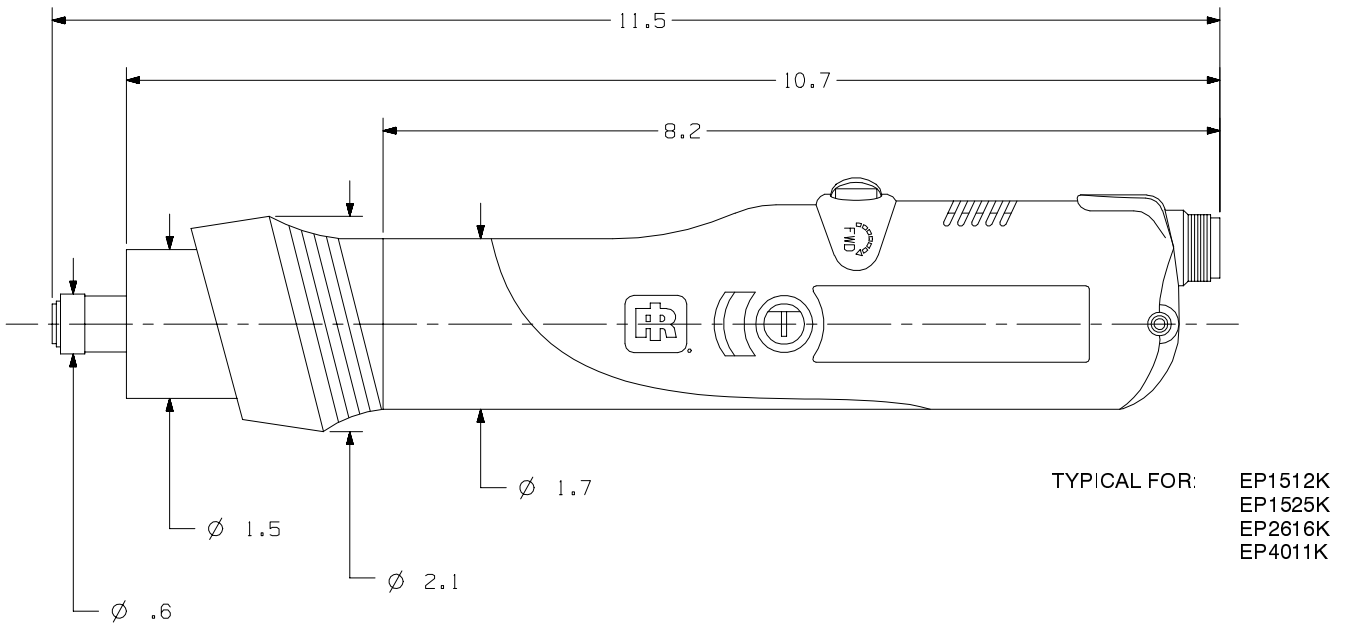

(Dwg. TPC637)

MAINTENANCE SECTION

Dimension for Series EL/EP/ET Electric Screwdrivers

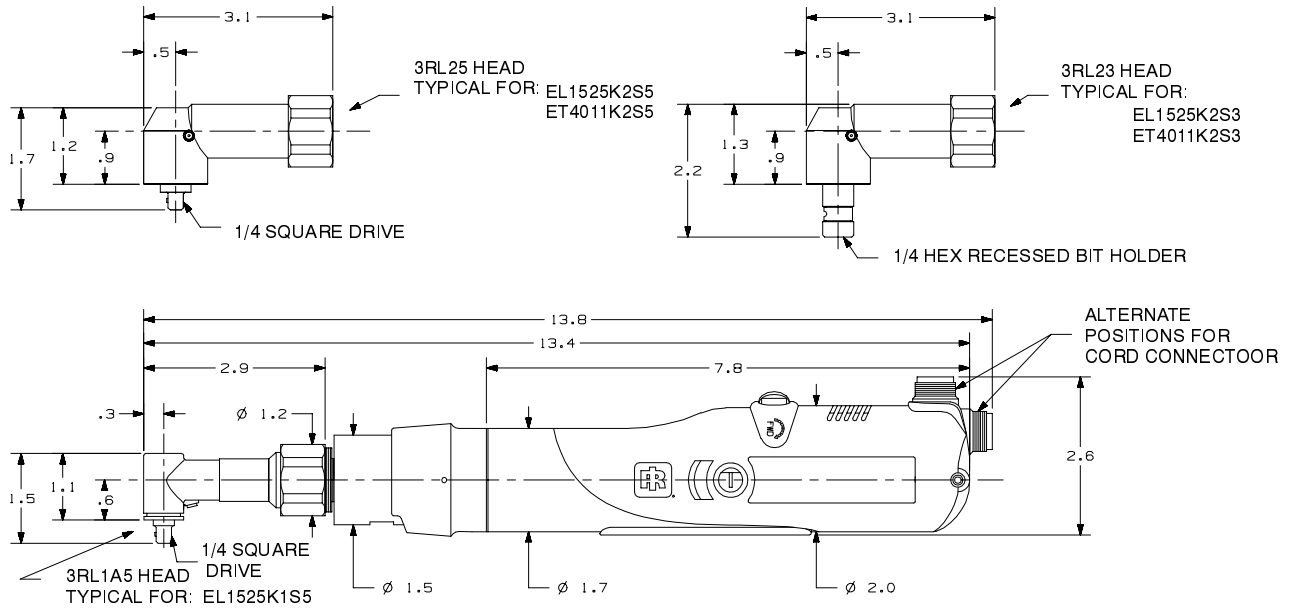

(Dwg. TPC639)

Handle for Series EL/EP/ET Electric Screwdrivers

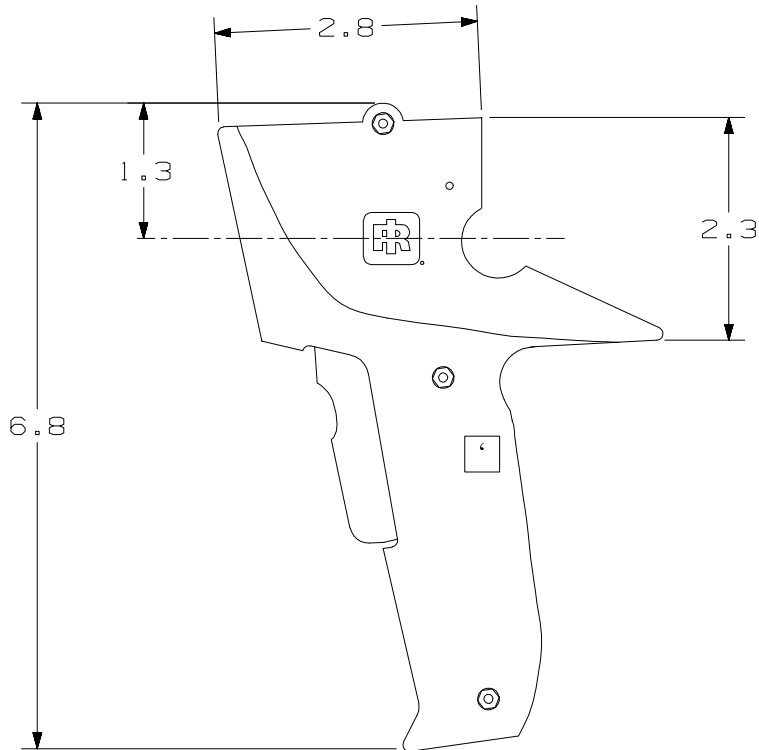

(Dwg. TPD1829)

Models EL1512K, EL1525K, EL2616K and ET4011K

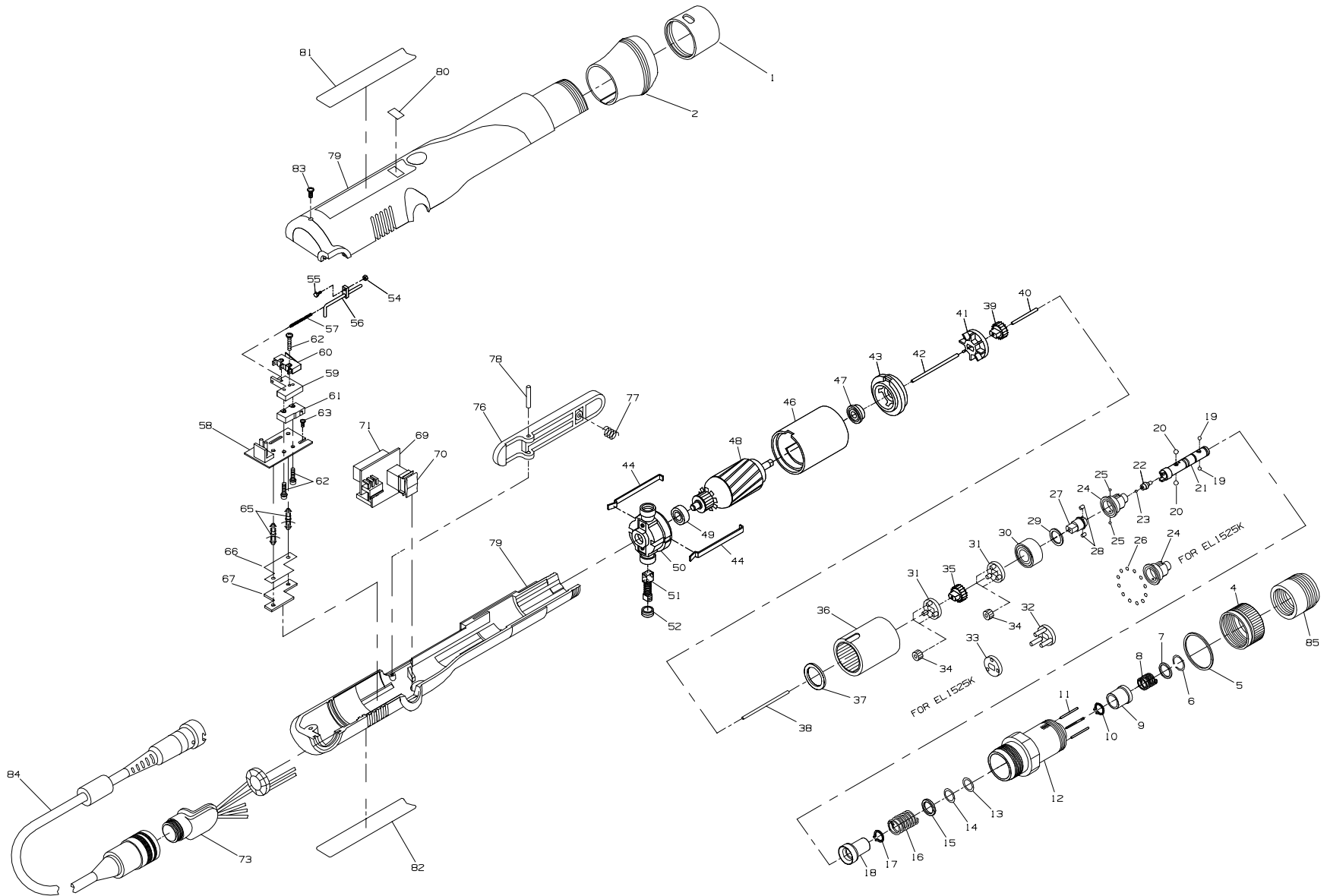

MAINTENANCE SECTION

(Dwg. TPA1528)

Models EL1512K, EL1525K, EL2616K and ET4011K Electric Screwdrivers



PART NUMBER FOR ORDERING

PART NUMBER FOR ORDERING

1	Retainer Coupling	EP4007N-125	25	Cam Guide Ball (.156 dia.) (2)	2U-696
2	Slanted Flange (standard)	EP4007N-124	26	Cam Guide Bearing Ball (23) (.078 dia.)	
*	Straight Flange (optional)	EP4007N-123		for EL1525K	EL1520N-510
4	Clutch Adjusting Ring	EP4007N-582	27	Cam	
5	Indicator Ring	EP4007N-682		for ET4011K	EP4007N-581
6	Bit Retainer Retaining Ring (Front) (for models			for all others	EP1510N-581
	ending in K only)	EP4007N-683	28	Cam Roller (2)	EP4007N-587
7	Bit Retainer Collar (for models ending in K only) ..	EP4007N-585	29	Spindle Washer	
8	Bit Retainer Spring (for models ending in K only) ..	EP4007N-931		for EL1525K	EP1520N-509
9	Bit Retainer Sleeve (for models ending in K only) ..	EP4007N-930		for all others	EP4007N-509
10	Bit Retainer Retaining Ring	EP4007N-584	30	Spindle Bearing	EP4007N-510
11	Clutch Adjusting Pin (3)	EP4007N-416	31	Spindle/Gear Head (2)	
12	Clutch Housing Assembly			for EL1512K	EP2607N-216
	for models ending in 1S5, 2S3 or 2S5	ET4007N2S5-580		for EL2616K	EP2612N-216
	for all other models	EP4007N-580		for ET4011K	EP4007N-216
13	Front Shim	EL4007N-623	32	Gear Head (for EL1525K)	EP1520N-216
14	Rear Shim	EL4007N-624	33	Gear Head Spacer (for EL1525K)	EP1520N-108
15	Clutch Spring Plate	EP4007N-623	34	Planet Gear	
16	Clutch Spring			for EL1512K (6)	EP1510N-10
	for EL2616K	EP2607N-583		for ET4011K (6)	EP4007N-10
	for EL1512K	EP1510N-583		for EL2616K (6)	EP2612N-10
	for EL1525K	EP1520N-583		for EL1525K (3)	EP1520N-10
	for ET4011K	EP4007N-583	35	Gear Head Pinion Gear	
17	Taper Ring Retaining Ring	EP4007N-584		for EL1512K and EL1525K	EP1510N-17
18	Taper Ring Assembly			for ET4011K	EP4007N-17
	for EL1525K	EP1520N-588		for EL2616K	EP2612N-17
	for EL1512K and EL2616K	EP2607N-588	36	Gear Case	
	for ET4011K	EP4007N-588		for EL1512K	EP1510N-37
19	Bit Retaining Ball (.094" dia.) (2) (for models			for all others	EP4007N-37
	ending in K only)	R000B-263	37	Gear Case Shield	EP4007N-207
20	Pilot Cam Ball (.156 dia.) (2)	2U-696	38	Clutch Pilot Rod "I" (2.26" long)	EP4007N-435
21	Bit Holder Assembly	EP4007N-586			
22	Pilot	EP4007N-408			
23	Pilot Ball (.062 dia.)	EP4007N-422			
24	Cam Guide				
	for EL1525K	EP1520N-681			
	for all others	EP4007N-681			

* Not Illustrated

MAINTENANCE SECTION

Models EL1512K, EL1525K, EL2616K and ET4011K Electric Screwdrivers (Continued)

PART NUMBER FOR ORDERING

PART NUMBER FOR ORDERING

39	Fan Pinion Gear		56	Pilot Rod "D"	EP4007N-438
	for EL1512K	EP1510N-18	57	Pilot Rod Spring	EP4007N-595
	for ET4011K	EP4007N-18	58	Microswitch Circuit Board	ET4007N-220
	for EL2616K	EP2612N-18	59	Switch Plate	ET4007N-221
	for EL1525K	EP2603N-18	60	Shut-off Switch	EP4007N-223
40	Fan Pilot Rod "G" (.385" long)	EP4007N-436	61	Start Switch	ET4007N-222
41	Fan	EP4007N-52	62	Switch Screw (12mm) (4)	EP4007N-224
	for EL1525K	EL1525K-52	63	Switch Base Screw (5mm) (2)	EP4007N-226
	for all others	EP4007N-52	*	Wire Assembly	EP1512K-45
42	Motor Pilot Rod "J" (2.71" long)	EP4007N-437	65	Switch Base Spacer (2)	EP4007N-225
	Motor Assembly		66	Insulating Film	EP4007N-227
	for EL1512K	EP1512K-A53	67	Brush Light Circuit Board	EP1512K-228
	for EL1525K	EL1525K-A53		Reverse Switch Circuit Board Assembly	E4011K-A229
	for EL2616K and EL4011K	EP2616K-A53	69	Reverse Switch Circuit Board	EP4004E-229
43	Front End Plate	EP4007N-11	70	Reverse Switch	EP4007N-329
44	Motor Assembly Spring (2)	EP4007N-98	*	Reverse Switch Rocker	EP4007N-330
46	Field		71	Capacitor	EP4007N-230
	for EL1512K	EP2607N-54	73	Receptacle Assembly	EP1512K-44
	for all others	EP4007N-54	75A	Housing Assembly	
47	Front Armature Bearing	EP4007N-24		for EL1512K	EL1512K-A40
48	Armature			for EL2616K	EL2616K-A40
	for EL1512K	EP1512K-53		for ET4011K	EL4011K-A40
	for EL1525K	EP1525K-53		for EL1525K	EL1525K-A40
	for EL2616K and EL4011K	EP2616K-53	76	Throttle Lever	EL4007N-273
49	Rear Armature Bearing	EP4007N-22	77	Throttle Spring	EL4007N-274
50	Rear End Plate	EP1512K-12	78	Throttle Lever Pin	EL4007N-275
51	Brush Assembly (includes 10 pieces)	EP1512K-BP			
52	Brush Cap (2)	EP4007N-25			
54	Adjusting Screw Nut	EP4007N-593			
55	Pilot Rod Adjusting Screw	EP4007N-592			

* Not Illustrated

MAINTENANCE SECTION

Models EL1512K, EL1525K, EL2616K and ET4011K Electric Screwdrivers (Continued)

PART NUMBER FOR ORDERING 

PART NUMBER FOR ORDERING 

80	Brush Light Cover	EP4007N-45	*	Switch Adjustment Gauge (for high torque models)	EP1510N-SG
81	Nameplate		*	Gear Case Jig (for high torque models)	EP1510N-J37
	for EL1512K	EL1512K-301	*	Hardware Package (includes illustrated items 6, 10,	
	for EL2616K	EL2616K-301		17, 19[2], 44[2], 52[2], 54, 55, 62[4], 63[2], 66	
	for ET4011K	EL4011K-301		and 83	EL4007N-HP
	for EL1525K	EL1525K-301		Maintenance Label	
82	Warning Label	EP4004E-99	*	English	EP4007N-302
83	Housing Screw (package of 10)	EP4007N-41		French	EP4007N-302F
84	Power Cord	EP1512K-239		German	EP4007N-302G
85	Angle Head Coupling (for models ending in 1S5,			Spanish	EP4007N-302S
	2S3 or 2S5 only)	EL4007N2S5-AHC		Italian	EP4007N-302I
*	Microswitch Adjusting Wrench Package	ES60T-MSW	*	Extension Cord (2 m.l.)	EC29-249-2
*	Pistol Grip Assembly	EP4007N-48			

* Not illustrated.

MAINTENANCE SECTION

SERIES 3 ANGLE ATTACHMENTS FOR EL1525K1S5, EL1525K2S3, EL1525K2S5, ET4011K2S3 and ET4011K2S5

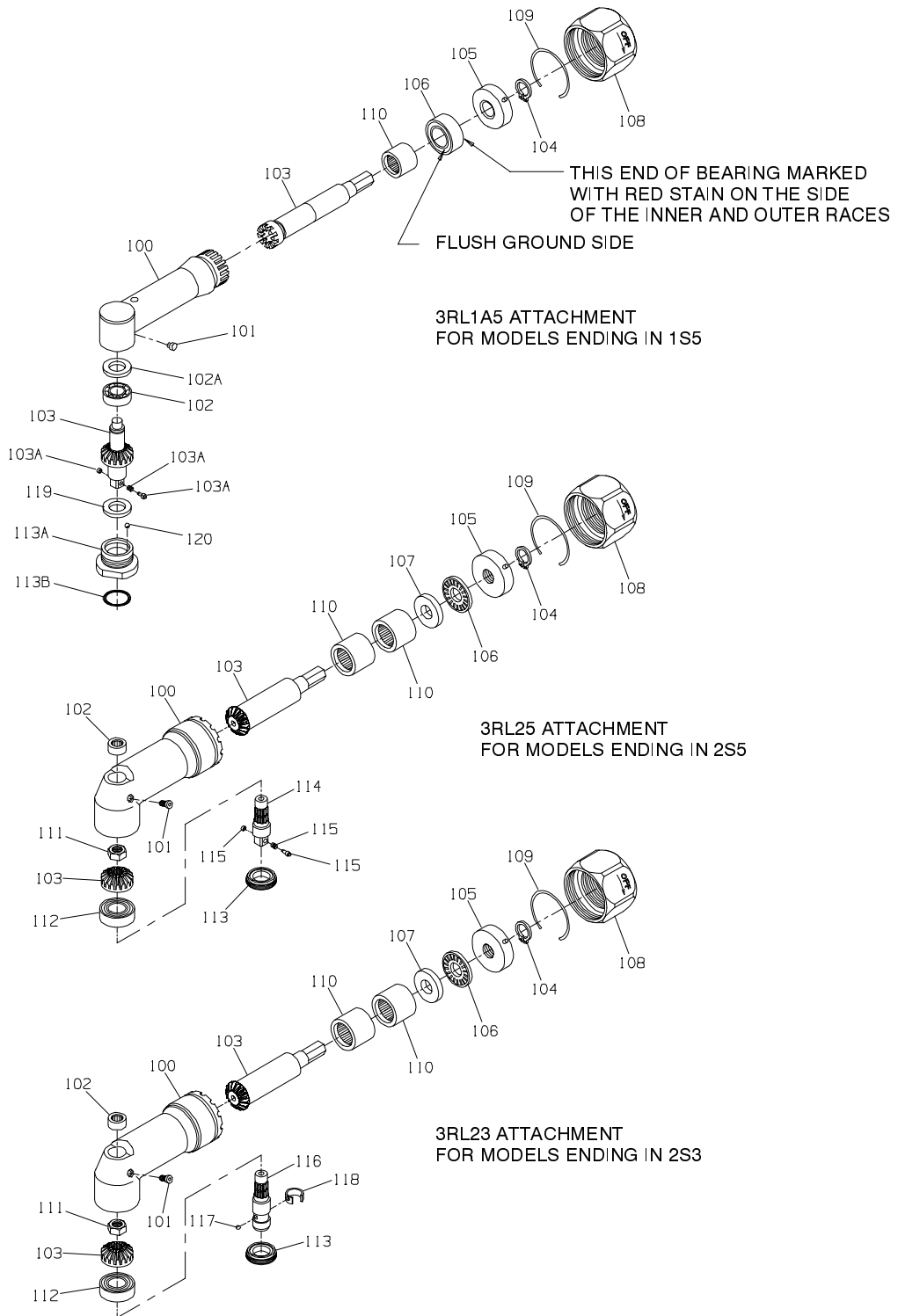

(Dwg. TPA1514)

MAINTENANCE SECTION

PART NUMBER FOR ORDERING



		For Models Ending in 1S5	For Models Ending in 2S3	For Models Ending in 2S5
	Angle Attachment	3RL1A5	3RL23	3RL25
100	Angle Housing Assembly	3RL1A-A550	3RL2-A550	3RL2-A550
101	Grease Fitting	D0F9-879	D059-879	D0F9-879
102	Spindle Upper Bearing	_____	120A4-603	120A4-603
102	Spindle Upper Bearing	7L1A-603	_____	_____
102A	Shim Packet	7L1A-P448	_____	_____
103	Matched Gear Set (Bevel Gear and Pinion not sold separately)	3RL1A5-A591	3RL2-A552	3RL2-A552
103A	Socket Retainer Assembly (consists of Plunger, Spring and Washer)	500B-816A	_____	_____
104	Thrust Bearing Retainer	3RL2-705	3RL2-705	3RL2-705
105	Rear Thrust Bearing Seal	3RL2-682	3RL2-682	3RL2-682
106	Bevel Pinion Thrust Bearing	3RL1A-514	3RL2-105	3RL2-105
107	Front Thrust Bearing Seat	_____	3RL2-683	3RL2-683
108	Coupling Nut	3RL2-27	3RL2-27	3RL2-27
109	Coupling Nut Retainer	3RL2-29	3RL2-29	3RL2-29
110	Bevel Pinion Bearing (2 for 3RL23) and 3RL25; 1 for 3RL1A5	7AH-24	H54U-511B	H54U-511B
111	Bevel Gear Retainer Nut	_____	120A4-578	120A4-578
112	Spindle Lower Bearing	_____	120A4-593	120A4-593
113	Angle Housing Cap	_____	120A4-531	120A4-531
113A	Angle Housing Cap Assembly	3RL1A-A531	_____	_____
113B	Angle Housing Cap Seal	3RL1A-513	_____	_____
114	1/4" Square Drive Spindle Assembly	_____	_____	141A9-607-1/4
•115	Socket Retainer (consists of Plunger Spring and Washer)	_____	_____	500B-816A
116	1/4" Hex Bit Holder Spindle Assembly (for standard bits)	_____	5L2C3-B586	_____
117	Bit Retaining Ball (.125" diameter)	_____	AV1-225	_____
118	Bit Retaining Spring	_____	102A60-241	_____
119	Ball Race	3RL1A-532	_____	_____
120	Steel Ball (1/16" diameter) (20)	3RL1A-512	_____	_____
*	Housing Cap Wrench	_____	141A12-26	141A12-26

* Not illustrated

- To keep downtime to a minimum, it is desirable to have on hand certain repair parts. We recommend that you stock one (pair or set) of each part indicated by a (•) for every four tools in service.

Models EP1512K, EP1525K, EP2616K and EP401K Electric Screwdrivers

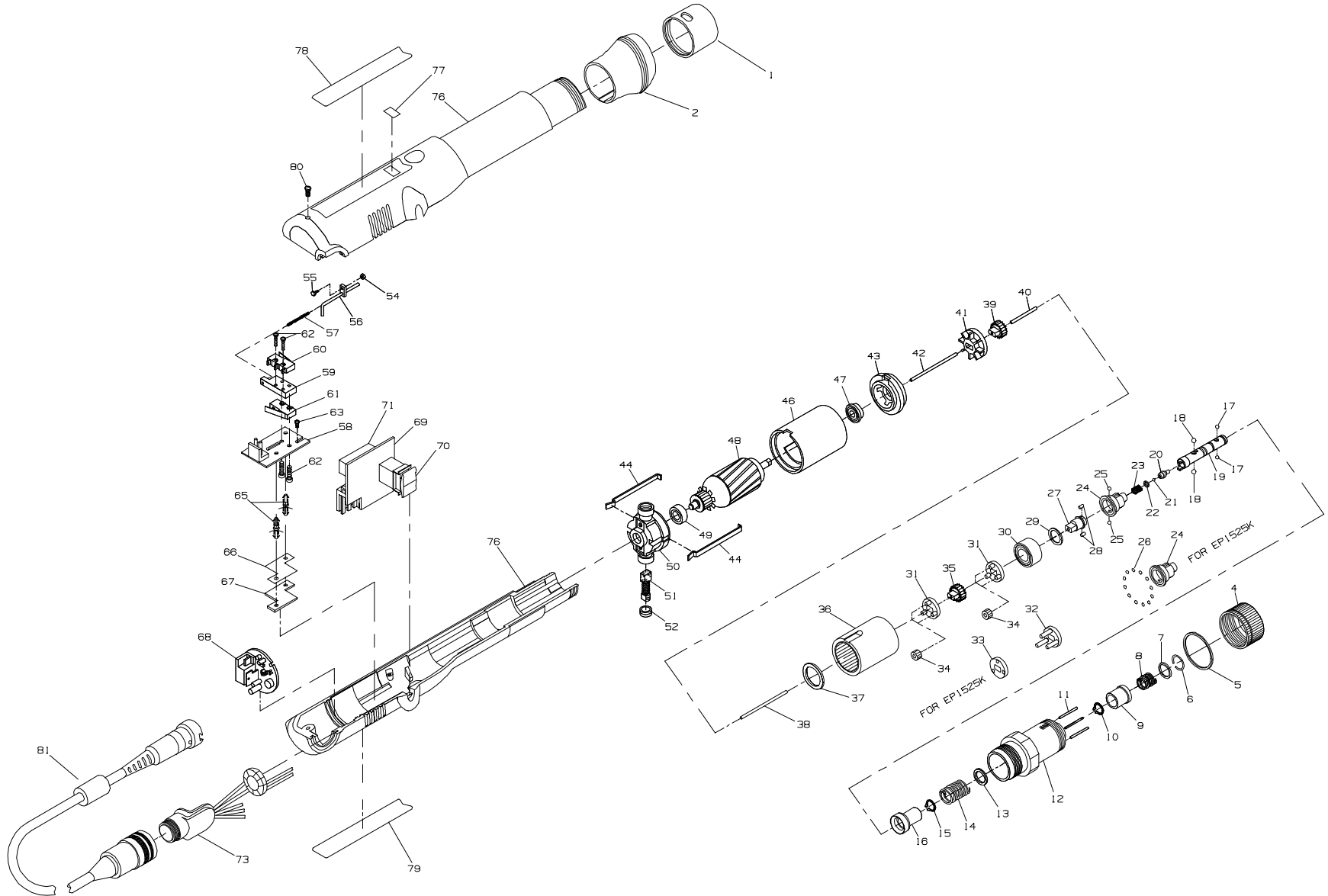

MAINTENANCE SECTION

Models EP1512K, EP1525K, EP2616K and EP4011K Electric Screwdrivers

PART NUMBER FOR ORDERING

PART NUMBER FOR ORDERING

1	Retainer Coupling	EP4007N-125	22	Pilot Push Spring Washer	EP4007N-421
2	Slanted Flange (standard)	EP4007N-124	23	Pilot Push Spring	EP4007N-420
*	Straight Flange (optional)	EP4007N-123	24	Cam Guide	EP4007N-681
4	Clutch Adjusting Ring	EP4007N-582		for EP1525K	EP1520N-681
5	Indicator Ring	EP4007N-682		for all others	EP4007N-681
6	Bit Retainer Retaining Ring (Front)	EP4007N-683	25	Cam Guide Ball (2) (.156 dia.)	2U-696
7	Bit Retainer Collar	EP4007N-585	26	Cam Guide Bearing Ball (23) (for EP1525K)	EP1520N-510
8	Bit Retainer Spring	EP4007N-931	27	Cam	
9	Bit Retainer Sleeve	EP4007N-930		for EP4011K	EP4007N-581
10	Bit Retainer Retaining Ring	EP4007N-584		for all others	EP1510N-581
11	Clutch Adjusting Pin (3)	EP4007N-416	28	Cam Roller (2)	EP4007N-587
12	Clutch Housing Assembly	EP4007N-580	29	Spindle Washer	
13	Clutch Spring Plate	EP4007N-623		for EP1525K	EP1520N-509
14	Clutch Spring			for all others	EP4007N-509
	for EP4011K	EP4007N-583	30	Spindle Bearing	EP4007N-510
	for EP2616K	EP2607N-583	31	Spindle/Gear Head (2)	
	for EP1525K	EP1520N-583		for EP1512K	EP2607N-216
	for EP1512K	EP1510N-583		for EP2616K	EP2612N-216
15	Taper Ring Retaining Ring	EP4007N-584		for EP4011K	EP4007N-216
16	Taper Ring Assembly		32	Gear Head (for EP1525K)	EP1520N-216
	for EP4011K	EP4007N-588	33	Gear Head Spacer (for EP1525K)	EP1520N-108
	for EP1525K	EP1520N-588	34	Planet Gear	
	for EP2616K and EP1512K	EP2607N-588		for EP1512K	EP1510N-10
17	Bit Retaining Ball (.094" dia.) (2)	R000B-263		for EP26016K	EP2612N-10
18	Pilot Cam Ball (2) (.156 dia.) (4)	2U-696		for EP4011K	EP4007N-10
19	Bit Holder Assembly	EP4007N-586		for EP1525K (3)	EP1520N-10
20	Pilot	EP4007N-408			
21	Pilot Ball (.062 dia.)	EP4007N-422			

* Not illustrated.

Models EP1512K, EP1525K, EP2616K and EP4011K Electric Screwdrivers

PART NUMBER FOR ORDERING



PART NUMBER FOR ORDERING

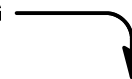

35	Gear Head Pinion Gear for EP1512K and EP1525K	EP1510N-17	48	Armature for EP1512K	EP1512K-53
	for EP4011K	EP4007N-17		for EP1525K	EP1525K-53
	for EP2616K	EP2612N-17		for EP2616K and EP4011K	EP2616K-53
36	Gear Case for EP1512K	EP1510N-37	49	Rear Armature Bearing	EP4007N-22
	for all others	EP4007N-37	50	Rear End Plate	EP4007N-12
37	Gear Case Shield	EP4007N-207	51	Brush Assembly (includes 10 pieces)	EP1512K-BP
38	Clutch Pilot Rod "I" (2.26" long)	EP4007N-435	52	Brush Cap (2)	EP4007N-25
39	Fan Pinion Gear for EP1512K	EP1510N-18	54	Adjusting Screw Nut	EP4007N-593
	for EP4011K	EP4007N-18	55	Pilot Rod Adjusting Screw	EP4007N-592
	for EP2616K	EP2612N-18	56	Switch Pilot Rod "D"	EP4007N-438
	for EP1525K	EP2603N-18	57	Pilot Rod Spring	EP4007N-595
40	Fan Pilot Rod "G" (.385" long)	EP4007N-436	58	Microswitch Circuit Board	EP4007N-220
41	Fan	EP4007N-52	59	Switch Plate	EP4007N-221
	for EP1525K	EL1525K-52	60	Shut-off Switch	EP4007N-223
	for all others	EP4007N-52	61	Start Switch	EP4007N-222
42	Motor Pilot Rod "J" (2.71" long)	EP4007N-437	62	Switch Screw (12 mm) (4)	EP4007N-224
	Motor Assembly for EP1512K	EP1512K-A53	63	Switch Base Screw (5 mm) (2)	EP4007N-226
	for EP1525K	EP1525K-A53	*	Wire Assembly	EP1512K-45
	for all others	EP2616K-A53	65	Switch Base Spacer (2)	EP4007N-225
43	Front End Plate	EP4007N-11	66	Insulating Film	EP4007N-227
44	Motor Assembly Spring (2)	EP4007N-98			
46	Field for EP1512K	EP2607N-54			
	for all others	EP4007N-54			
47	Front Armature Bearing	EP4007N-24			

* Not illustrated.

Models EP1512K, EP1525K, EP2616K and EP4011K Electric Screwdrivers (Continued)

PART NUMBER FOR ORDERING 

PART NUMBER FOR ORDERING 

67	Brush Light Circuit Board	EP1512K-228	81	Power Cord	EP1512K-239
	Reverse Switch Circuit Board Assembly	EP4011K-A229	*	Microswitch Adjusting Wrench Package	ES60T-MSW
69	Reverse Switch Circuit Board	EP4004E-229	*	Pistol Grip Assembly	EP4007N-48
70	Reverse Switch	EP4007N-329	*	Extension Cord	EC29-249-2
71	Capacitor	EP4007N-230	*	Switch Adjustment Gauge (for high torque models)	EP1510N-SG
73	Receptacle Assembly	EP1512K-44	*	Gear Case Jig (for high torque models)	EP1510N-J37
	Housing Assembly		*	Hardware Package (includes illustrated items 6, 10, 15, 17 [2], 44 [2], 52 [2], 54, 55, 62 [4], 63 [2], 66, and 80	EP4007N-HP
	for EP1512K	EP1512K-A40			
	for EP2616K	EP2612K-A40			
	for EP4011K	EP4011K-A40	*	Maintenance Label	
	for EP1525K	EP1525K-A40		English	EP4007N-302
76	Housing Package	EP4007N-40		French	EP4007N-302F
77	Brush Light Cover	EP4007N-45		German	EP4007N-302G
78	Nameplate			Spanish	EP4007N-302S
	for EP1512K	EP1512K-301		Italian	EP4007N-302I
	for EP2616K	EP2616K-301			
	for EP4011K	EP4016K-301			
	for EP1525K	EP1525K-301			
79	Warning Label	EP4004E-99			
80	Housing Screw (package of 10)	EP4007N-41			

* Not illustrated.

MAINTENANCE SECTION

⚠ WARNING

Maintenance procedures have the potential for severe shock hazard and should be performed by qualified personnel.

DISASSEMBLY

⚠ WARNING

Always wear eye protection when operating or performing maintenance on this tool. Always turn off the electrical supply and disconnect the electrical cord before installing, removing or adjusting any accessory on this tool, or before performing any maintenance on this tool.

Disassembly of the Housing

1. Unplug the Power Cord (81 or 84) from the wall socket. Unscrew the connection ring and set the cord aside.
2. Unscrew the Retainer Coupling (1) and remove the Flange (2).

NOTICE

This is a left-hand thread.

3. Lay the tool on the workbench with the Brush Light Plate (77 or 80) side down and remove the Housing Screw (80 or 83) using a #1 phillips screwdriver.
4. Insert a thin blade screwdriver into the two notches and carefully pry the two halves of the Housing Package (76) apart.

For Throttle Lever Start Models, remove the Throttle Lever (76), Throttle Spring (77) and Throttle Lever Pin (78).

Disassembly of the Clutch Housing and Gear Case

NOTICE

Be sure to hold the Motor Assembly and Gear Case together. Rough handling may damage the Fan Pilot Rod (40) in the Fan (41).

1. Remove the Clutch Housing and Gear Case from the Housing. When removing the Gear Case from the Housing, hold the Gear Case Shield (37) so that the Gears do not fall out.
2. Remove the Fan (41) and the Fan Pinion Gear (39). Remove the Fan Pilot Rod (40).

NOTICE

The Fan Pilot Rod is ceramic. Do not mishandle or drop.

3. Remove the Gear Case Shield and drop the two Spindle/Gear Heads (31) from the Gear Case.
4. Separate the Spindle/Gear Heads and remove the Gear Head Pinion Gear (35) and Planet Gears (34).

5. Fit the two notches at the rear of the Gear Case into the Gear Case Jig part no. EP1510N-J37. (Refer to Dwg. TPD1820).

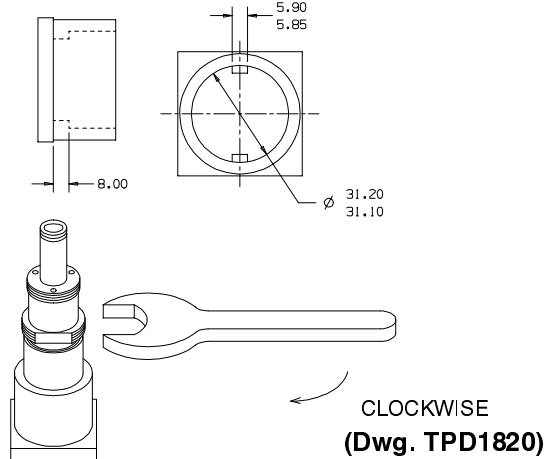

6. Using a thin blade screwdriver, remove the Front Bit Retainer Retaining Ring (6) from the bit Retainer Sleeve (9). Remove the Bit Retainer Collar (7), the Bit Retainer Spring (8) and the Bit Retainer Sleeve.
7. Remove the two Bit Retaining Balls (17 or 19) from the bit Holder Assembly (19 or 21) by tapping the Housing on the work surface.
8. Unscrew the Clutch Adjusting Ring (4) and remove the three Clutch Adjusting Pins (11).
9. Using external snap ring pliers, remove the Bit Retainer Retaining Ring (10).
10. Using a 29mm wrench on the flats of the Clutch Housing, unscrew and remove the Clutch Housing from the Gear Case.

NOTICE

This is a left-hand thread.

11. Remove the Clutch Spring Plate (13 or 15) and the Clutch Spring (14 or 16).
12. Remove the Taper Ring Retaining Ring (15 or 17).
13. Remove the Bit Holder Assembly and separate it from the Taper Ring Assembly (16 or 18).
14. Remove the two Pilot Cam Balls (18 or 20), the Pilot Push Spring (23), the Pilot Push Spring Washer (22) and the Pilot (20 or 22) from the Bit Holder Assembly.
15. **For Throttle Lever Start Models**, remove the Front Shim (13) and the Rear Shim (14) first. Then remove the Taper Ring Retaining Ring. Separate the Taper Ring Assembly from the Bit Holder. Remove the two Pilot Cam Balls and the Pilot (22) from the Bit Holder Assembly.

MAINTENANCE SECTION

16. Remove the Clutch Pilot Rod (38) and the Cam Guide (24). Remove the two Cam Guide Balls (25) from the Guide.
17. Lift the Gear Case from the Gear Case Jig and push the Spindle Bearing (30) and Cam (27) from the Case.
18. Lift the Cam from the Spindle Bearing and remove the Cam Rollers (28).
19. Slide the Spindle Washer (29) from the Spindle Bearing.

Cleaning and Inspection of the Tool

1. Clean all of the mechanical parts in an approved safety solution in a well-ventilated area. Inspect for damage or wear.
2. Inspect the Fan. If the four corners of the hole are worn, replace the Fan.
3. Inspect the Fan Pinion Gear and Fan Pilot Rod. If they are damaged or cracked, replace them.
4. If the taper on the Pilot is worn, replace the Pilot and the two Pilot Cam Balls.
5. Inspect the Cam Guide Balls. If they are worn, replace them.
6. Inspect the Cam Guild. If its holes are worn, replace it.
7. Inspect the Taper Ring Assembly. If the internal taper is worn, replace it.
8. Inspect the Cam Rollers. If they are worn, replace them.
9. Inspect the Spindle Washer. If the surface is worn, replace it.
10. Inspect the Spindle Bearing. If it does not rotate smoothly, replace it.
11. Inspect the Gears and the Gear Case. If the teeth are worn, replace them.

Disassembly of the Electrical Components

1. Remove the Reverse Switch Circuit Board (69) from the Housing.

NOTICE

Do not touch any circuit paths if using pliers.

2. Loosen the Receptacle Assembly (73).
3. Using a #0 phillips screwdriver, remove the two Switch Base Screws (63) mounted on the Microswitch Circuit Board (58).

NOTICE

The Switch Base Screws are coated with thread adhesive. Unscrew gradually to prevent damage to the threads.

4. Remove the Motor Assembly and from the Housing Package.

NOTICE

Be careful not to damage the Motor Pilot Rod (42).

5. Remove the two-pin connector from the Microswitch Circuit Board.
6. Using needle nose pliers, remove the three wires from the Shut-off Switch (60).

NOTICE

Be careful not to damage the Shut-off Switch Terminals.

7. Set the Controller Assembly aside.
8. Grasp the Microswitch Circuit Board using needle nose pliers and squeeze the ends of the two white Switch Base Spacers (65). Lift the Brush Light Circuit Board (67) from the Switch Base Spacers.
9. Using needle nose pliers, squeeze the Switch Base Spacers and remove the Insulating Film (66).
10. Using the pliers, remove the Switch Base Spacers from the Brush Light Circuit Board.
11. Remove the two Shut-off Switch Screws (62).
12. Remove the two Start Switch Screws (62).
13. Remove the Switch Plate (59) and the Switch Pilot Rod (56) from the Switch Plate.
14. Inspect the tip of the Switch Pilot Rod. If it is bent or worn, replace it.
15. Check the Shut-off Switch for continuity. Replace it if defective.
16. Check the Start Switch (61) for continuity. If it is defective, desolder and remove it from the Microswitch Circuit Board.
17. If the Brush Light Circuit Board is defective, desolder and remove the red and blue wires.
18. If the components on the Reverse Switch Circuit Board are damaged or defective, desolder and remove the red and blue wires.
19. If the Reserve Switch (70) is damaged, desolder and replace.
20. If the Capacitor (71) is damaged, desolder and replace it.

MAINTENANCE SECTION

Disassembly of the Motor

1. Remove the Brush Caps (52) from the Rear End Plate (50). Using a pick, catch the terminal of the Brush Assembly (51) and pull it out of the Rear End Plate.

NOTICE

Do not damage the copper wires of the Brush Assembly. Reinstall the Brushes as they were removed unless they are replaced

2. Remove the insulation tape around the Motor.
3. Using a thin blade screwdriver, remove the Motor Assembly Springs (44) by inserting the screwdriver between the Springs and the Rear End Plate and prying upward
4. Remove the Rear End Plate and the Front End Plate (43) from the Field (46).
5. Pushing the Armature (48) toward the Fan side, remove the Armature from the Field.
6. Do not damage the commutator or the windings of the Armature. Hold the rotor, not the commutator.
7. Remove the Motor Pilot Rod from the Armature and inspect it. If it is worn, replace it.
8. Remove the Front Armature Bearing (47) and the Rear Armature Bearing (49) from the Armature and inspect them. If they do not rotate smoothly, replace them.
9. Inspect the Armature, Field and End Plates. Use a piece of fine cloth to wipe away contamination. For excess build up, spray with contact cleaner and brush if necessary.
10. To clean the commutator on the Armature, spray with contact cleaner and brush if necessary.
11. Using a test, inspect the commutator. Replace the Armature if necessary.

ASSEMBLY

Assembly of the Motor Housing

1. Install the Front Armature Bearing (47) and the Rear Armature Bearing (49) to the Armature shaft ends.
2. Apply grease to both ends of the Motor Pilot Rod (42) and insert it into the center hold of the Motor Assembly.
3. Insert the Armature through the notched end of the Field (46).

NOTICE

Be careful not to damage the commutator or the windings. Hold the rotor, not the commutator, when assembling.

4. Install the Rear End Plate (50) to the notched end and the Front End Plate (43) to the field.
5. Snap the two Motor Assembly Springs (44) over the notches of the Rear End Plate and the Front End Plate.
6. Insert the Brush Assemblies (51) into the brush holders of the Rear End Plate. Be sure the tab on the Brush Assembly slides into the notch in the holder.
7. Screw on the Brush Caps (52).
8. Wrap one layer of 3M #56 insulation tape around the Motor Assembly.
9. **For Throttle Lever Start Models**, put two additional strips of insulation tape, one upon the other, onto the Brush Light Circuit Board (67) side of the Motor Assembly.

Assembly of the Electrical Components

1. Solder the red and blue wires to the Brush Light Circuit Board.
2. Solder the Reverse Switch. Using shrink tubing 5mm long as spacers, solder the Capacitor (71) into place. Solder the red and blue wires to the Reserve Switch Circuit Board (69).
3. Solder the Start Switch (61) onto the Microswitch Circuit Board (58).
4. Insert the Switch Pilot Rod (56) into the hole in the Switch Plate (59). (Refer to Dwg. TRD1819).

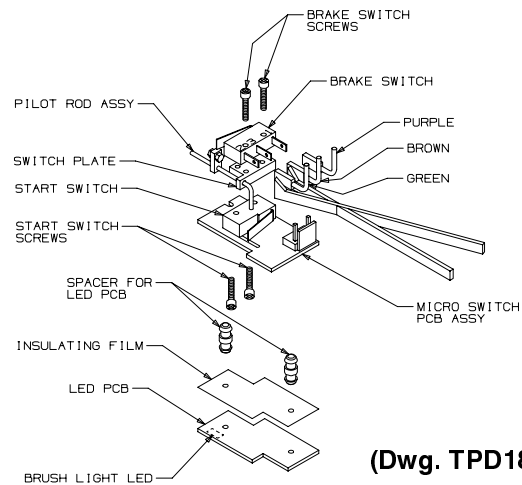

MAINTENANCE SECTION

5. Mount the Switch Plate with the Pilot Rod onto the Start Switch by depressing the Start Switch lever with the Pilot Rod. Insert the Pilot Rod into the slot in the Microswitch Circuit Board and align the Switch Plate on top of the Start Switch. Insert the two Switch Base Screws (63) from the bottom of the Microswitch Circuit Board into the Switch Plate. Tighten the Screws to 1.6 KG-cm.
6. Mount the Shut-off Switch (60) onto the Switch Plate with the two Switch Screws (62). Tighten the screws to 1.6 KG-cm.
7. Position the Insulating Film (66) onto the back of the Brush Light Circuit Board. Insert the two Switch Base Spacers (65) through the Insulating Film and into the holes of the Circuit Board.
8. Install the Brush Light Circuit Board onto the back of the Microswitch Circuit Board by inserting the Two Switch Base Spacers into the holes in the Circuit Board.

NOTICE

Be sure that the Brush Light LED is toward the motor side of the circuit board.

9. Using needle nose pliers, install the three connectors onto the Shut-off Switch.

NOTICE

Make sure to connect the correct color wire to the proper terminal. Refer to the wiring diagram to insure that all wires are installed properly.

10. Install the two-pin connector from the Controller Assembly onto the Microswitch Circuit Board.
11. Install the three-pin connector onto the Reverse Switch Circuit Board.
12. Bring the Motor Assembly and Microswitch Circuit Board together by inserting the Motor Pilot Rod into the hole in the Motor shaft and then setting both into the Housing Package (76).
13. Install the two Switch Base Screws and tighten to 1.6 KG-cm.
14. Install the Reverse Switch Circuit Board into the two grooves in the Housing.
15. Install the Receptacle Assembly (73) into the Housing. The Receptacle can be installed in either position.
16. Place the ceramic Fan Pilot Rod (40) into the Fan Pinion Gear (39) and then fit the Gear into the Fan (41). Now slide the Fan (41) onto the Motor shaft.

Assembly of the Gear Case and Clutch Housing

1. Apply grease to the Planet Gears (34), the surfaces of the Gear Heads (32) and the teeth of the Gear Head Pinion Gear (35).

2. Assemble the Spindle/Gear Heads, the Gear Head Pinion Gear and the Gear Head.
3. Apply grease to all the Gears.
4. Place the Gear Head onto the Spindle/Gear Heads.
5. Apply grease to the Spindle Washer (29).
6. Place the Spindle Washer, then the Spindle Bearing (30), onto the Cam (27).
7. Apply grease to the inner teeth of the Gear Case (36).
8. Insert the Cam into the Spindle Bearing.
9. Hold the Cam with needle nose pliers and insert the entire unit into the Gear Case while rotating the Cam and the Gear Case.
10. Apply grease to the gear end of the Gear Case and install the Gear Case Shield (37).
11. Apply grease to the notches of the Cam.
12. Place the Cam Rollers (28) into the notches on the Cam.
13. Apply grease to the inner surface, the holes and the grooves of the Cam guide (24).
14. Insert the Cam Guide Balls (25) into the holes in the Cam Guide.
15. Install the Cam Guide over the Cam. Keep the Cam Balls at a 90 degree angle to the Cam Rollers to prevent the Balls from being pushed out.
16. Apply grease to the inner surface of the Bit Holder Assembly (19 or 22). Using a rod, push the Pilot (20 or 22) into the Bit Holder.
17. **For Push to Start Models**, insert the Pilot Push Spring Washer (22) and the Pilot Push Spring (23) into the bit Holder.
Throttle Lever Start Models do not use a Push Spring and Washer.
18. Apply grease to the holes of the Bit Holder and insert the two Pilot Cam Balls (18 or 20).
19. Apply grease to the inner diameter and the tapered end of the Taper Ring Assembly (16 or 18). Insert grease between the ball bearing thrust washer and the Taper Ring Assembly, which are attached. Install the Taper Ring Assembly onto the Bit Holder.
20. Install the Bit Holder Assembly onto the Cam Guide in the Gear Case.
21. The Taper Ring Retaining Ring (15 or 17) has a round edge side and a sharp edge side. Install the Taper Ring Retaining Ring, sharp edge side first, into the groove on the Bit Holder.

NOTICE

There are four grooves on the Bit Holder. The fourth groove from the bit end is for Push to Start Models. The third is for Throttle Lever Start Models.

MAINTENANCE SECTION

22. **For Throttle Lever Start Models**, place the Spindle Washers onto the Bit Holder.
23. Place the Clutch Spring (14 or 16) and the Clutch Spring Plate (13 or 15) over the Bit Holder.
24. Fit the two notches at the rear end of the Gear Case Assembly into the Gear Case Jig part no. EP1510N-J37. Screw the Clutch Housing (12) partially into the Gear Case.

NOTICE

This is a left-hand thread.

At the middle of the Clutch Housing Threads, apply Loctite Threadlocker 3 Bond 1406®* to about three threads. Push down and rotate the Bit Holder until it engages the Cam Guide. Hold in place. Screw the Clutch Housing in completely.

25. Using an open end torque wrench on the flats of the Clutch Housing, tighten the Clutch Housing to 28.5 Nm.
26. Apply grease to both ends of the Clutch Pilot Rod (36 or 38) and insert it into the Gear Case.
27. **For Throttle Lever Start Models**, inspect the clearance of the bit Holder Assembly. Touch the end of the Clutch Pilot Rod and push on the Bit Holder Assembly. If the Clutch Pilot Rod is moved by the Bit Holder at this time, add additional spacers.
28. Install the Bit Retainer Retaining Ring (10), sharp edge side first, into the second groove from the bit end of the Bit holder.
29. Apply grease to the holes of the Bit Holder and insert the two bit Retaining Balls (17 or 19) into the holes.
30. Apply grease to one end of each Clutch Adjusting Pin (11) and insert the three Pins into the Clutch Housing.
31. Apply grease to the other end of each Clutch Adjusting Pin and the threads of the Clutch Housing. Screw the Clutch Adjusting Ring (4) onto the Housing.
32. Install the Bit Retainer Sleeve (9), the Bit Retainer Spring (8) and the Bit Retainer Collar (7) onto the Bit Holder.
33. Using a thin blade screwdriver, install the Front Bit Retainer Retaining Ring (6).
34. Unclamp the Gear Case Jig from the vise and turn it over to remove the Clutch and Gear Case Assembly. Hold the Gear Case Shield to keep the Gears in place.
35. Lift the Motor slightly and slide the Gear Case onto the Motor.
36. Turn the Gear Case until the notch in the Gear Case matches the tab in the Housing.

Adjusting the Brake Timing

1. Insert a .65mm thick gauge or pin gauge between the Pilot Rod Adjusting Screw (55) head and the Shut-off Switch. Push the Bit Holder. **The shut-off Switch should not click.**
2. Insert a .80mm gauge and push the Bit Holder. **The Shut-off Switch should click.**
3. Adjust the Pilot Rod Adjusting Screw if necessary using the two adjusting spanner wrenches.
4. **For Throttle Lever Start Models**, there is no need to push the Bit Holder. Slide the gauges between the Pilot Road Adjusting Screw and the Throttle Lever (76).

Assembly of the Tool

1. Make sure all components are in place and snap the Housing halves together.
2. **For Throttle Lever Start Models**, insert the Throttle Lever Pin (78) into the Housing. Insert the Throttle Spring (77) into the Throttle Lever. While compressing the Throttle Spring, install the Throttle Lever onto the throttle Lever Pin. Snap the Housing halves together.
3. Install the Housing Screws (80 or 83) into the Housing and tighten to 4 KG-cm.
4. Slide the Flange (2) onto the Housing. Screw the Retainer Coupling (1) onto the Housing until it clicks into place.

NOTICE

These are left-hand threads.

5. Attach the Power Cord (81 or 84).

Testing the Tool

1. Test forward and reverse operation by pressing the Bit Holder against the work surface with the Reverse Switch in each position.
2. Tighten the Clutch Adjusting Ring all the way, reverse it one turn and test for proper shut off operation and maximum torque.
3. Reset the Clutch Adjusting Ring to mid scale and check for torque repeatability by cycling the tool between five and ten times.
4. For repair and troubleshooting of the high torque low voltage Controller, refer to the operation and maintenance manual.

WIRING DIAGRAM FOR EP1525K "K" SERIES TOOLS

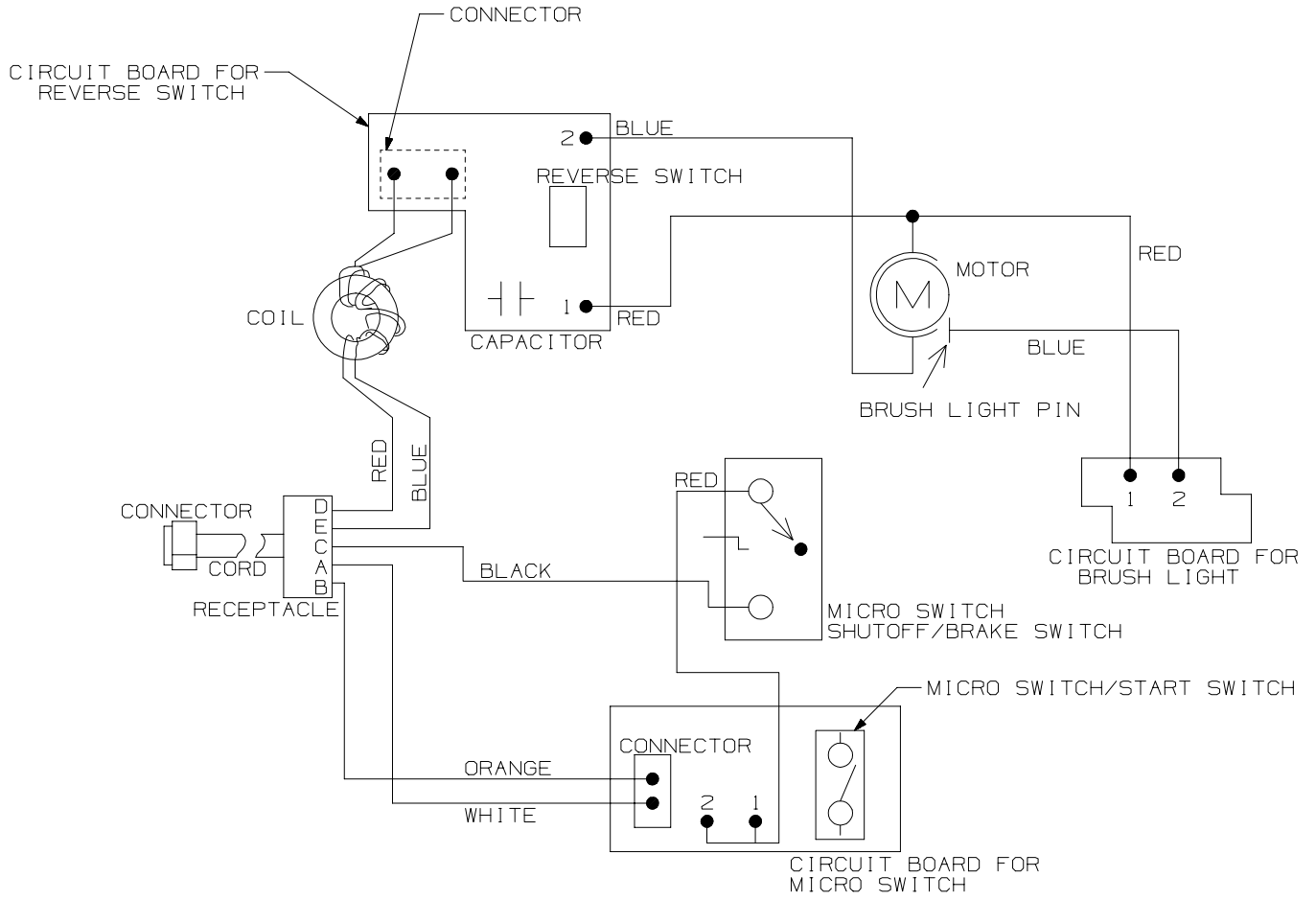

(Dwg. TPA1532)

MAINTENANCE SECTION

TROUBLESHOOTING GUIDE

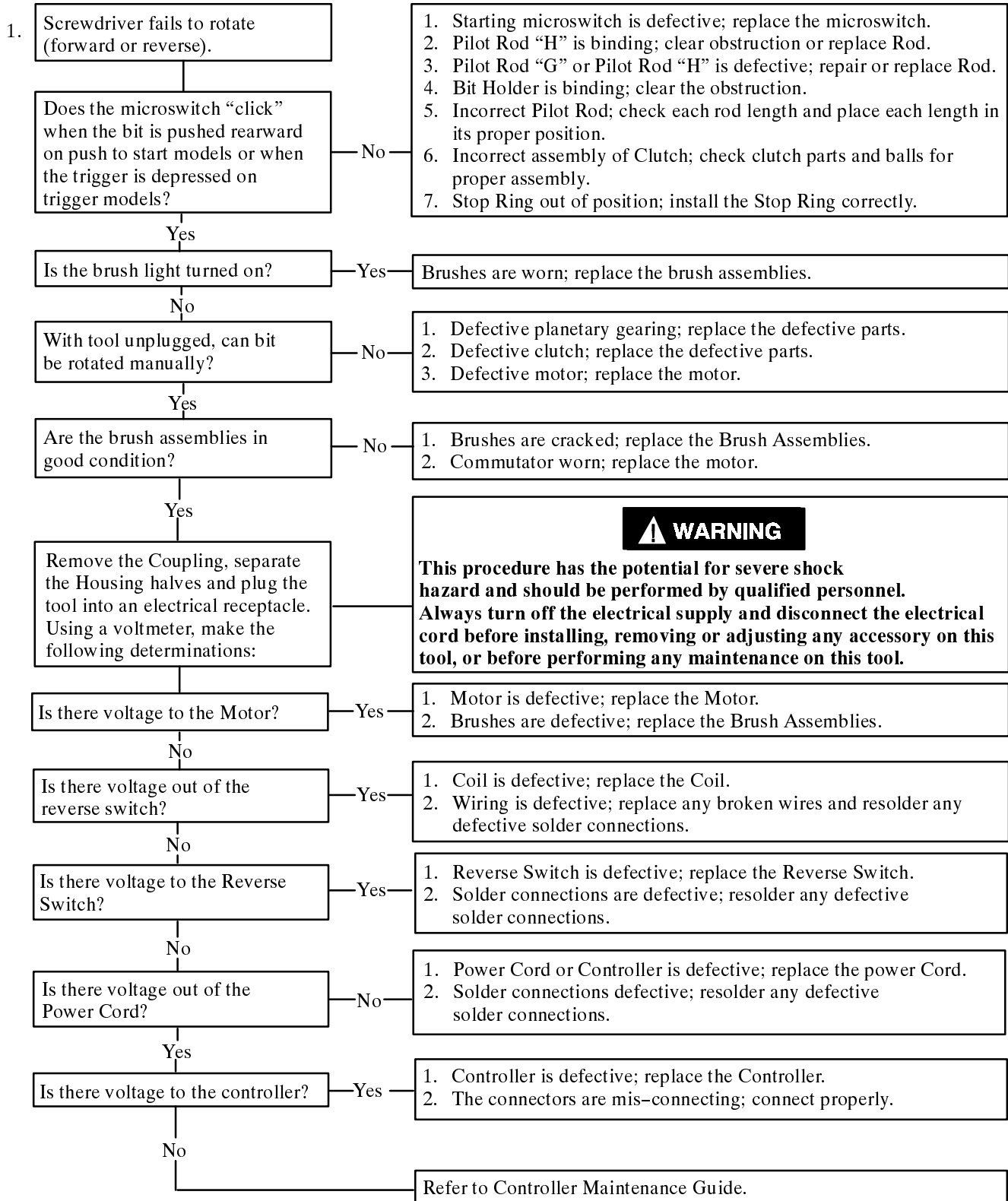

MAINTENANCE SECTION TROUBLESHOOTING (Continued)

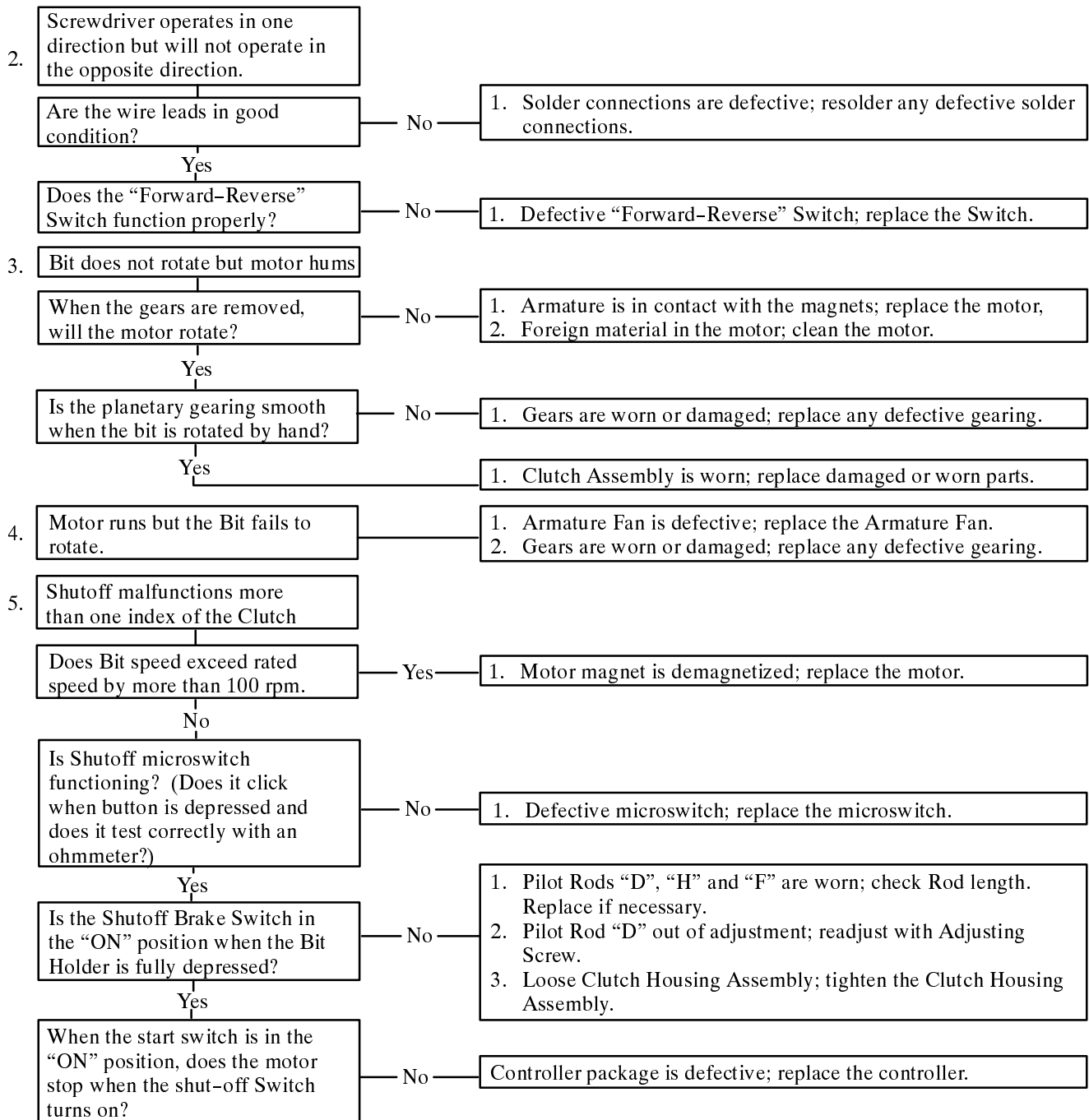

MAINTENANCE SECTION

TROUBLESHOOTING (Continued)

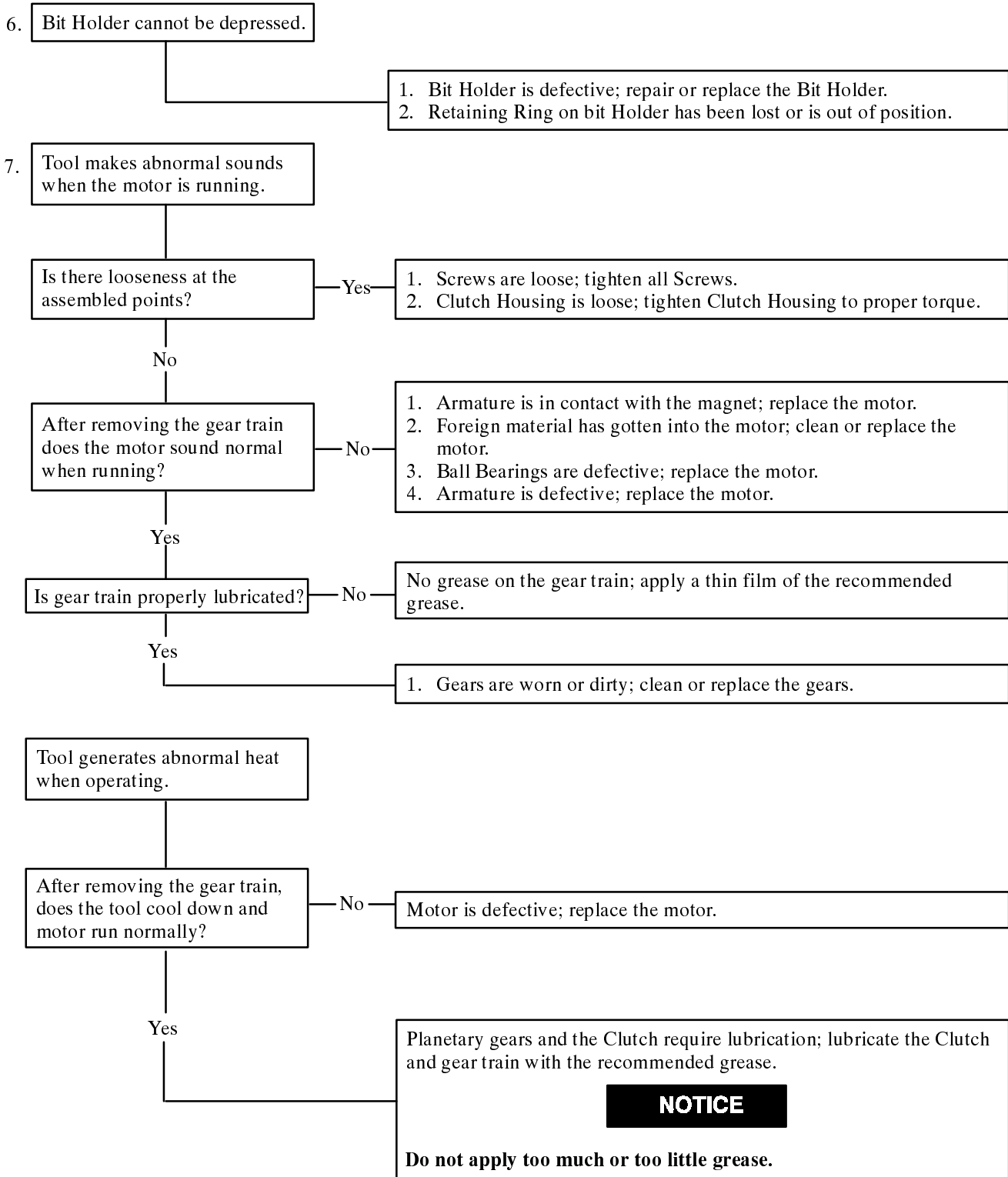

MAINTENANCE SECTION

TROUBLESHOOTING (Continued)

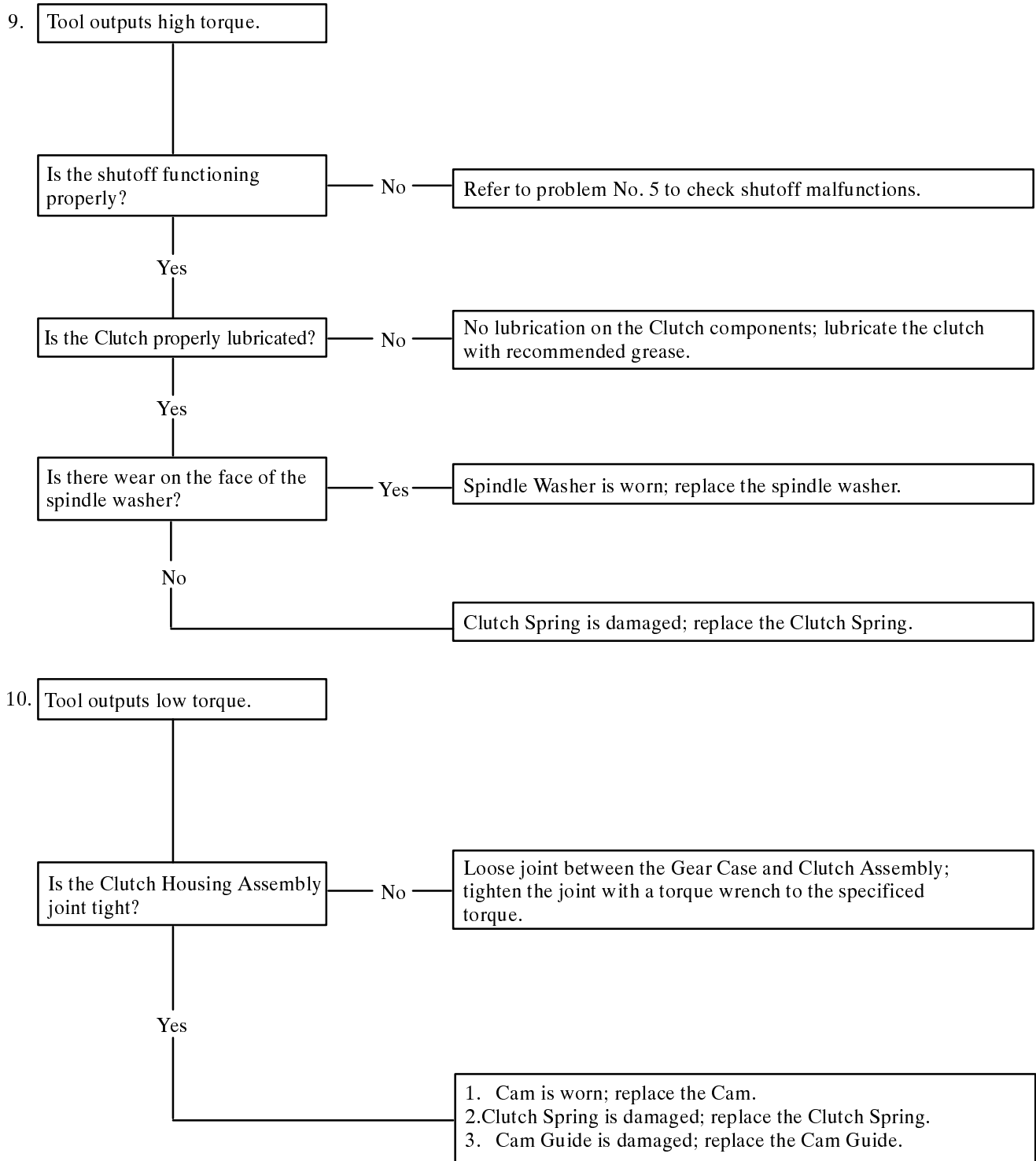

**Service Centers
Centres d'entretien
Niederlassungen
Centri di Assistenza
Centros de Servicio
Service Centra**

Ingersoll-Rand Company
510 Hester Drive
White House
TN 37188
USA
Tel: 1 800 TOOL HLP

Ingersoll-Rand
Sales Company Limited
Chorley New Road
Horwich Bolton
Lancashire BL6 6JN
England
UK
Tel: (44) 1204 690690
Fax: (44) 1204 690388

Ingersoll-Rand
Equipements de Production
111 avenue Roger Salengro
BP 59
F - 59450 Sin Le Noble
France
Tél: (33) 27 93 0808
Fax: (33) 27 93 0800

Ingersoll-Rand GmbH
Gewerbeallee 17
45478 Mülheim/Ruhr
Deutschland
Tel: (49) 208 99940
Fax: (49) 208 9994445

Ingersoll-Rand Italiana SpA
Casella Postale 1232
20100 Milano
Italia
Tel: (39) 2 950561
Fax: (39) 2 95360159

Ingersoll-Rand Ibérica
Camino de Rejas 1, 2-18
28820 Coslada (Madrid)
España
Tel: (34) 1 6695850
Fax: (34) 1 6696054

Ingersoll-Rand Nederland
Produktieweg 10
2382 PB Zoeterwoude
Nederland
Tel: (31) 71 5452201
Fax: (31) 71 5218671

Ingersoll-Rand Company SA
PO Box 3720
Alrode 1451
South Africa
Tel: (27) 11 864 3930
Fax: (27) 11 864 3954

Ingersoll-Rand
Scandinavian Operations
Kastruplundgade 22, I
DK - 2770 Kastrup
Danmark
Tlf: (45) 32 526092
Fax: (45) 32 529092

Ingersoll-Rand SA
The Alpha Building
Route des Arsenaux 9
CH -1700 Fribourg
Schweiz/Suisse
Tel: (41) 37 205111
Fax: (41) 37 222932

Ingersoll-Rand Company
Kuznetsky Most 21/5
Entrance 3
103698 Moscow
Russia
CIS
Tel: (7) 501 882 0440
Fax: (7) 501 882 0441

Ingersoll-Rand Company
16 Pietro
Ul Stawki 2
00193 Warsaw
Poland
Tel: (48) 2 635 7245
Fax: (48) 2 635 7332