

OPERATOR'S MANUAL

INCLUDING: OPERATION, INSTALLATION & MAINTENANCE

Released: 6-1-95

Revised: 12-17-95

Form: P7188

03541018

RANDOM ORBITAL SANDER

Models RO35A-PS()-(), RO36A-PS()-(),
RO35A-CSV-() and RO36A-CSV-().



⚠ WARNING

**READ THIS MANUAL CAREFULLY BEFORE INSTALLING,
OPERATING OR SERVICING THIS EQUIPMENT.**

FAILURE TO OBSERVE THE FOLLOWING WARNINGS COULD RESULT IN INJURY.

Pneumatic tools should always be installed and used in accordance with A.N.S.I. B186.1 "Safety Code For Portable Air Tools."

⚠ WARNING

- Operate this tool at 90 p.s.i.g. (6.2 bar) maximum air pressure at the air inlet of the tool.
- Disconnect air supply from tool before removing/installing sanding disc, pad or performing maintenance procedures.
- Keep hands, clothing and long hair away from rotating end of tool.
- Anticipate and be alert for sudden changes in motion during start up and operation of any power tool.
- Never exceed rated r.p.m. of tool.
- Wear suitable eye and hearing protection while operating tool.
- Pad will continue to rotate briefly after throttle is released.
- Do not lubricate tools with flammable or volatile liquids such as kerosene, diesel or jet fuel.
- Do not remove any labels. Replace any damaged label.
- Use only accessories recommended by Ingersoll-Rand.

⚠ WARNING

Repeated prolonged operator exposure to vibrations which may be generated in the use of certain hand-held tools may produce Raynaud's phenomenon, commonly referred to as Whitefinger disease. The phenomenon produces numbness and burning sensations in the hand and may cause circulation and nerve damage as well as tissue necrosis. Repetitive users of hand-held tools who experience vibrations should closely monitor duration of use and their physical condition.

NOTICE

- The use of other than genuine Ingersoll-Rand replacement parts may result in safety hazards, decreased tool performance and increased maintenance and may invalidate all warranties.
- Ingersoll-Rand is not responsible for customer modification of tools for applications on which Ingersoll-Rand was not consulted.
- Tool maintenance and repair should be performed by authorized, trained, competent personnel. Consult your nearest Ingersoll-Rand authorized servicer.
- It is the responsibility of the employer to place the information in this manual into the hands of the operator.

For parts and service information, contact your local ARO distributor, or the Customer Service Dept. of the Ingersoll-Rand Distribution Center, White House, TN at PH: (615) 672-0321, FAX: (615) 672-0801.

FAILURE TO OBSERVE THE FOLLOWING WARNINGS COULD RESULT IN INJURY.

⚠ WARNING



Wear eye protection when operating or performing maintenance on this tool.

⚠ WARNING



Wear hearing protection when operating this tool.

⚠ WARNING



Turn off air supply and disconnect air supply hose before installing, removing or adjusting any accessory on this tool, or before performing any maintenance on this tool.

⚠ WARNING



Air powered tools can vibrate in use. Vibration, repetitive motions or uncomfortable positions may be harmful to your hands and arms. Stop using any tool if discomfort, tingling feeling or pain occurs. Seek medical advice before resuming use.

⚠ WARNING



Do not carry the tool by the hose.

⚠ WARNING



Do not use damaged, frayed or deteriorated air hoses and fittings.

⚠ WARNING



Do not overreach when operating this tool. Keep body stance balanced and firm.

⚠ WARNING

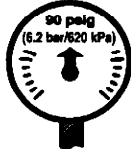

Operate at 90 p.s.i.g. (6.2 bar/620 kPa) maximum air pressure.

⚠ CAUTION

Use only sanding pads rated at or above tool r.p.m.

WARNING = Hazards or unsafe practices which could result in severe personal injury, death or substantial property damage.

CAUTION = Hazards or unsafe practices which could result in minor personal injury or product or property damage.

NOTICE = Important installation, operation or maintenance information.

ROUTINE LUBRICATION REQUIREMENTS

Air line debris, moisture and carry-over oil from the compressor can restrict the muffler and leave contaminants in the motor. Every 160 hours of tool operation, or sooner if motor speeds drop below accepted speed, flush the tool with a solution of equal parts of cleaning solvent and spindle oil. Flush the muffler with cleaning solvent and blow out any trapped debris.

EVERY 160 HOURS OF TOOL OPERATION – Inject grease #68, one or two strokes, thru threaded end of spindle (26) for lubrication of needle bearing contained in counterbalance (23). Sanding pad must be removed from spindle to allow injection of grease.

AIR SUPPLY REQUIREMENTS

This tool has been designed to operate without air line lubrication. Introduction of a lubricant with a standard filter/regulator/lubricator will not effect tool life.

For maximum operating efficiency, the following air supply specifications should be maintained to this air tool:

- AIR PRESSURE – 90 p.s.i.g. (6.2 bar)
- AIR FILTRATION – 50 micron
- HOSE SIZE – 5/16" (8 mm) I.D.

An IR model C05-02-G00 air line FILTER/REGULATOR/LUBRICATOR is recommended to maintain the above air supply of air to the tool.

RECOMMENDED LUBRICANTS

After disassembly is complete, all parts, except sealed or shielded bearings, should be washed with solvent. To relubricate parts, or for routine lubrication, use the following recommended lubricants:



Where Used	IR Part #	Description
"O" Rings & Lip Seals	IR36460	4 oz. Stringy Lubricant
Gears and Bearings	#68	5 lb. "EP" – NLGI #1 Grease

INSPECTION, MAINTENANCE AND INSTALLATION

Disconnect air supply from the tool or shut off air supply and exhaust (drain) line of compressed air before performing maintenance or service to the tool.

It is important that the tools be serviced and inspected at regular intervals for maintaining safe, trouble-free operation of the tool.

Be sure that the air supply lines and connectors are of proper size to provide a sufficient quantity of air to the tool.

Tool maintenance and repair shall be performed by authorized, trained, competent personnel. Tools, hose and fittings shall be replaced if unsuitable for safe operation and responsibility should be assigned to be sure that all tools requiring guards or other safety devices shall be kept in legible condition. Maintenance and repair records should be maintained on all tools. Frequency of repair and the nature of the repairs can reveal unsafe application. Scheduled maintenance by competent authorized personnel should detect any mistreatment or abuse of the tool and worn parts. Corrective action should be taken before returning the tool for use.

Disassembly should be done on a clean work bench with a clean cloth spread to prevent the loss of small parts. After disassembly is completed, all parts should be thoroughly washed in a clean solvent, blown dry with air and inspected for wear levels, abuse and contamination. Double sealed or shielded bearings should never be placed in solvent unless a good method of re-lubricating the bearing is available. Open bearings may be washed but should not be allowed to spin while being blown dry.

Upon reassembling, lubricate parts where required. Use #68 grease, or equivalent, in bearings. Use IR36460 lubricant for "O" ring assembly. When assembling "O" rings or parts adjacent "O" rings, care must be exercised to prevent damage to the rubber sealing surfaces. A small amount of grease will usually hold steel balls and other small parts in place while assembling.

When replacement parts are necessary, consult drawing containing the part for identification.

Always use clean, dry air. Dust, corrosive fumes and/or excessive moisture can damage the motor of an air tool. An air line filter can greatly increase the life of an air tool. The filter removes rust, scale, moisture and other debris from the air lines. Low air pressure (less than 90 p.s.i.g.) reduces the speed of the air tool. High air pressure (more than 90 p.s.i.g.) raises performance beyond the rated capacity of the tool and could cause injury. Shown below is a typical piping arrangement.

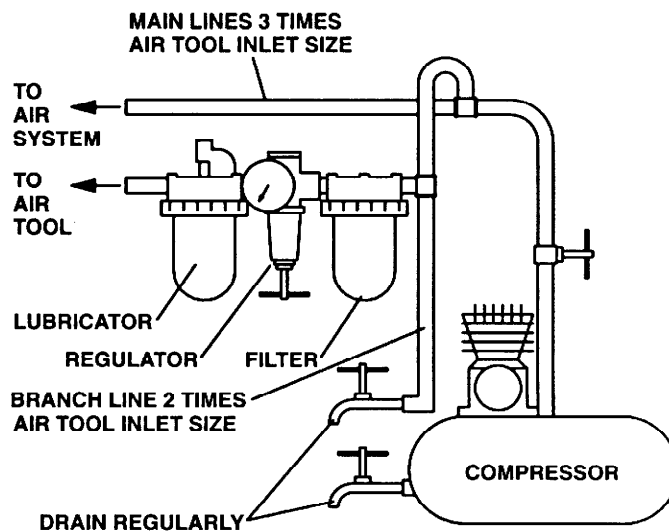

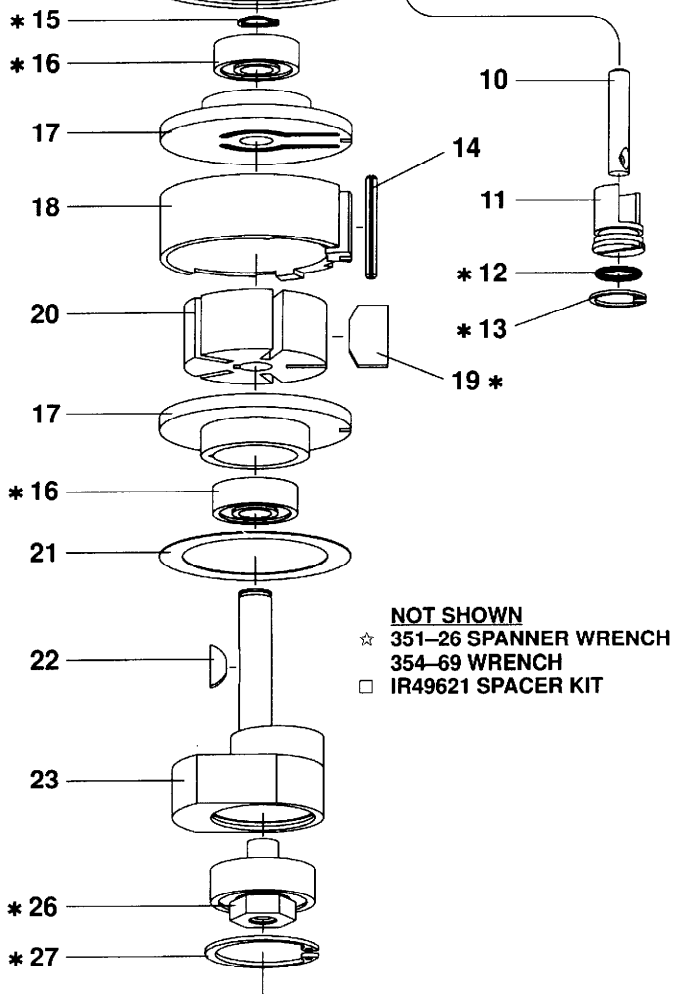
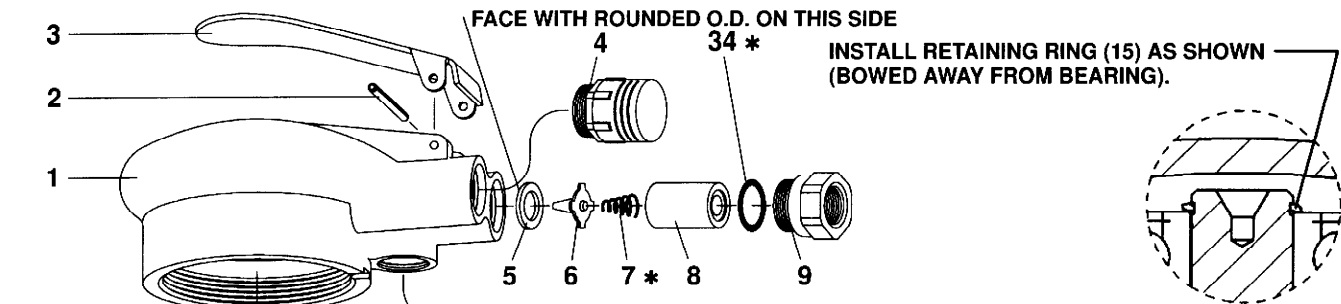

PART NUMBER FOR ORDERING

1	Housing	See table
2	Roll Pin	351-15
3	Lever	See table
4	Muffler	351-23
5	Seat	351-210
6	Tip Valve	351-302
7	Spring	351-51
8	Spacer	See table
9	Inlet Adapter	351-565
10	Valve Stem	351-161
11	Regulator	351-249
12	"O" Ring	351-159
13	Retaining Ring	351-118
14	Roll Pin	351-120
15	Retaining Ring	351-119
16	Bearing (2 req'd)	351-24
17	End Plate (2 req'd)	351-11
18	Cylinder	351-3
19	Blade (5 req'd)	351-42
20	Rotor	351-53
21	Spacer	351-111
22	Key	351-405
23	Counterbalance (includes needle bearing)	
	for models RO35A-()	IR49808-5
	for models RO36A-()	351-236A
26	Spindle Assembly (includes bearing)	351-8A
27	Retaining Ring	351-28A
28	Guard	351-931
29	"O" Ring	351-259
30	Lock Ring	351-218
31	Sanding Pad	See table
32	Shroud	354-931A
33	Sleeve (not shown)	See table
34	"O" Ring	IRY325-14

Service Kit: includes items 7, 12, 13, 15, 16, 19, 26, 27, 29 and 34 IR49846

* ITEMS INCLUDED IN SERVICE KIT NO. IR49846.
 ☆ EXTRA COST ITEM (NOT INCLUDED WITH TOOL).
 □ MODELS RO3()A-CSV-() ONLY.

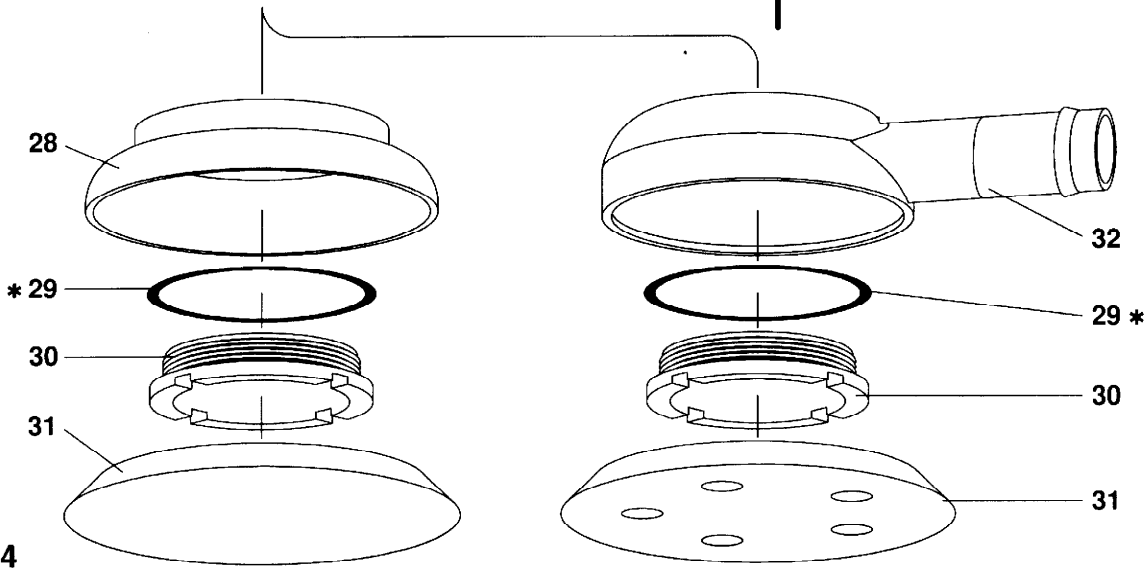

MODEL NUMBER	R.P.M.	HOUSING (1)	LEVER (3)	SPACER (8)	SANDING PAD (31)	SLEEVE (33)	PAD SIZE
RO35A-PSD	10,000	351-40	351-273		IR49095-1	351-170	5"
RO35A-PSD-EU	10,000	351-40	351-273-1		IR49095-1	351-170	5"
RO35A-PSV	10,000	351-40	351-273		IR49094-1	351-170	5"
RO35A-PSV-EU	10,000	351-40	351-273-1		IR49094-1	351-170	5"
RO35A-PSD-L	10,000	352-40	351-273	352-111	IR49095-1	352-170	5"
RO35A-PSD-L-EU	10,000	352-40	351-273-1	352-111	IR49095-1	352-170	5"
RO35A-PSV-L	10,000	352-40	351-273	352-111	IR49094-1	352-170	5"
RO35A-PSV-L-EU	10,000	352-40	351-273-1	352-111	IR49094-1	352-170	5"
RO36A-PSD	10,000	351-40	351-273		IR49098-1	351-170	6"
RO36A-PSD-EU	10,000	351-40	351-273-1		IR49098-1	351-170	6"
RO36A-PSV	10,000	351-40	351-273		351-825-6A	351-170	6"
RO36A-PSV-EU	10,000	351-40	351-273-1		351-825-6A	351-170	6"
RO36A-PSD-L	10,000	352-40	351-273	352-111	IR49098-1	352-170	6"
RO36A-PSD-L-EU	10,000	352-40	351-273-1	352-111	IR49098-1	352-170	6"
RO36A-PSV-L	10,000	352-40	351-273	352-111	351-825-6A	352-170	6"
RO36A-PSV-L-EU	10,000	352-40	351-273-1	352-111	351-825-6A	352-170	6"
RO35A-CSV	10,000	351-40	351-273		IR49096-1	351-170	5"
RO35A-CSV-EU	10,000	351-40	351-273-1		IR49096-1	351-170	5"
RO36A-CSV	10,000	351-40	351-273		354-825-6A	351-170	6"
RO36A-CSV-EU	10,000	351-40	351-273-1		354-825-6A	351-170	6"

NOTE: -D = DUCK FACE PAD, -V = VINYL FACE PAD

MODELS WITH -EU SUFFIX ARE "EC" COMPLIANT MODELS.

DISASSEMBLY/ASSEMBLY INSTRUCTIONS

NOTICE

- Never apply excessive pressure by a holding device which may cause distortion of a part.
- Apply pressure evenly to parts which have a press fit.
- Apply even pressure to the bearing race that will be press fitted to the mating part.
- Use correct tools and fixtures when servicing this tool.
- Don't damage "O" rings when servicing this tool.
- Use only genuine Ingersoll-Rand replacement parts for this tool. When ordering, specify part number, description, tool model number and serial number.

MOTOR DISASSEMBLY

- Remove sanding pad (31).
- Remove retaining ring (27).
- Remove spindle assembly (26) (includes bearing). NOTE: Do not attempt to remove bearing from spindle.
- Remove bearing lock ring (30) (LEFT HAND THREADS), "O" ring (29) and guard (28) or shroud (32).
- Remove motor assembly and pin (14). NOTE: It may be necessary to tap housing with a soft face hammer to loosen motor from housing.
- Remove retaining ring (15).
- Using special brass blocks to fit around o.d. of cylinder, clamp around cylinder and press shaft of counterbalance thru bearing (16) and end plate (17).
- Remove blades (19), rotor (20) and key (22).
- Remove other bearing (16) and end plate (17).

MOTOR ASSEMBLY

- Press bearings (16) into end plates (17), pressing on outer race of bearings.
- Assemble spacer (21) over counterbalance (23).
- Press one end plate (17), with bearing (16), on shaft of counterbalance.
- Install key (22) in key slot.
- Assemble rotor (20) to counterbalance (23), aligning keyway to key (22).
- Assemble five rotor blades (19) to rotor slots - straight side out.

- Assemble cylinder (18) over rotor.
- Assemble end plate (17), with bearing (16), to shaft of counterbalance, pressing on inner race of bearing.
- Install retaining ring (15) to groove in counterbalance, with ring bowed away from motor.
- Align notches in end plates and cylinder and install roll pin (14) to notches.
- Assemble motor to housing, aligning pin (14) with groove in housing.
- Seat spacer (21) against end plate (17).
- Grease and assemble "O" ring (29) to bearing lock ring (30).
- Assemble guard (28) or shroud (32) over lock ring (30) and thread lock ring into housing - LEFT HAND THREADS. Tighten securely.
- Lubricate roller bearing contained in counterbalance with IR #68 grease.
- Assemble spindle assembly (26) to counterbalance (23), securing with retaining ring (27).
- Assemble sanding pad (31) to tool.

THROTTLE DISASSEMBLY

- Remove guard (28) or shroud (32) - see motor disassembly.
- Remove inlet adapter (9) and "O" ring (34), releasing spacer (8) (where applicable), spring (7) and valve (6). NOTE: Do not remove seat (5) unless damage is evident.
- Remove retaining ring (13), releasing regulator (11) with "O" ring (12) and valve stem (10).
- To remove lever, remove roll pin (2).

THROTTLE ASSEMBLY

- Grease and assemble "O" ring (12) to regulator (11).
- Assemble valve stem (10) to housing with hole in valve stem in line with housing to accept valve (6).
- Assemble valve (6) to housing, securing valve stem (10).
- Secure valve with spring (7), spacer (8) (where applicable), "O" ring (34) and inlet adapter (9).
- Assemble regulator (11) to housing, securing with retaining ring (13).

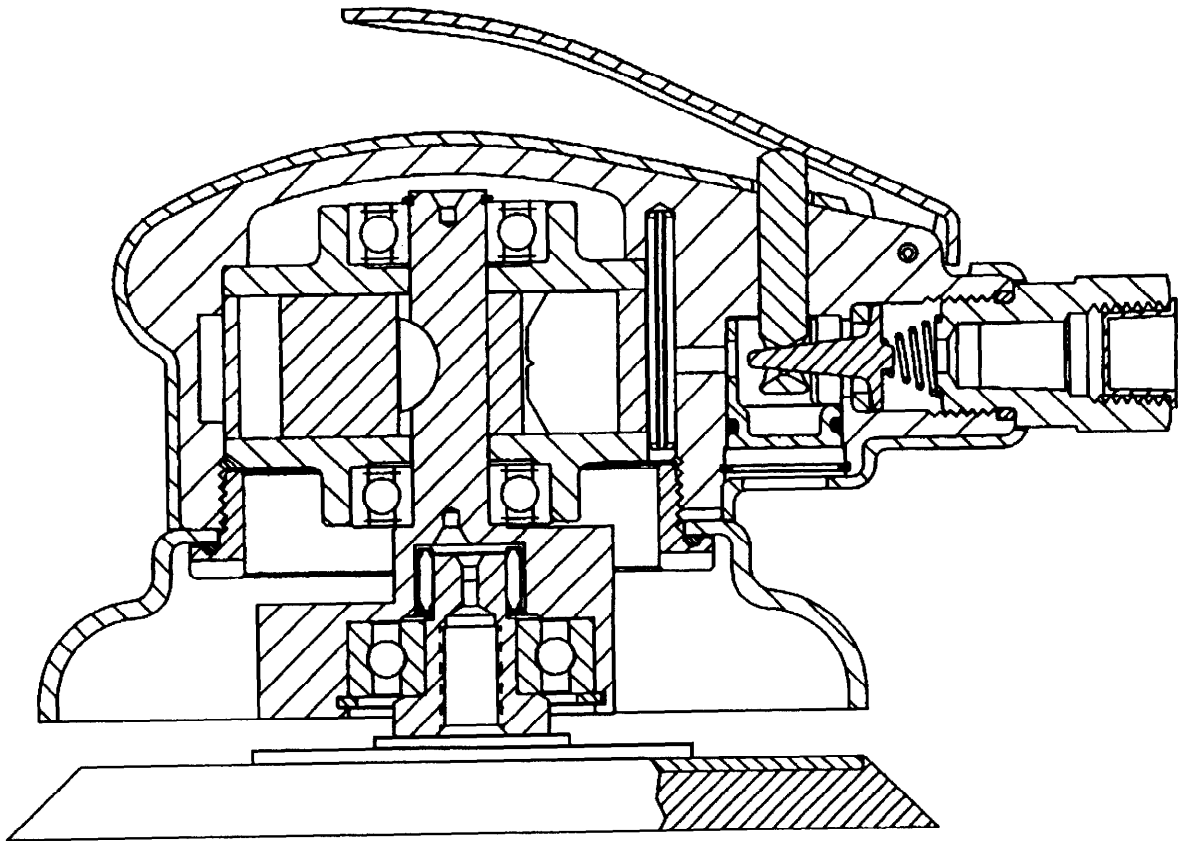

MODEL RO35A-PSV

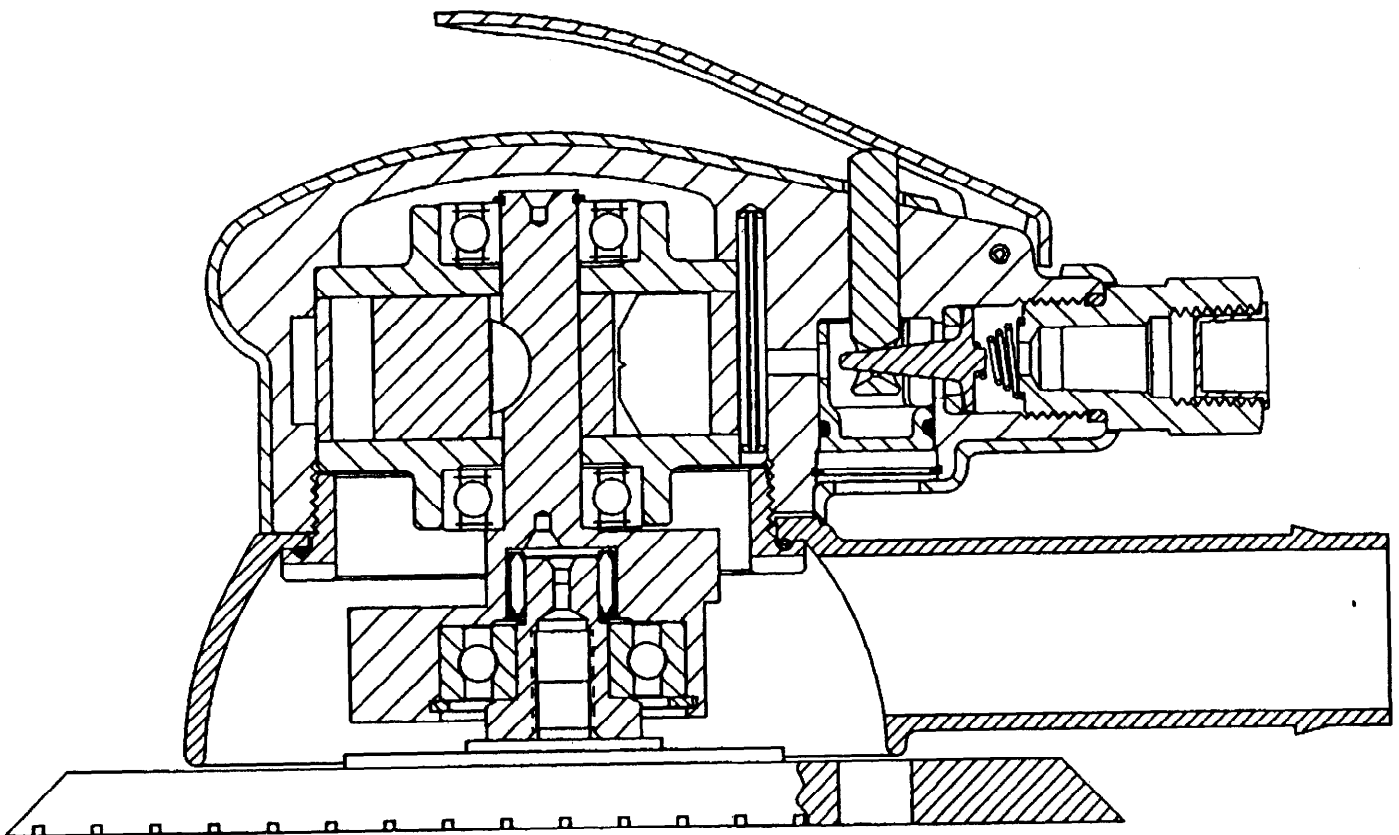

MODEL RO36A-CSV

