

OPERATION AND MAINTENANCE MANUAL FOR MODELS 130A1M and 241A1M RAMMERS

NOTICE

Model 130 Sand Rammer is designed for use in foundries for compacting sand in bench-level molds and patterns.

Model 241 Sand Rammer is designed for use in foundries for compacting sand in floor-level molds and patterns and tamping backfill in construction applications.

Ingersoll-Rand is not responsible for customer modification of tools for applications on which Ingersoll-Rand was not consulted.

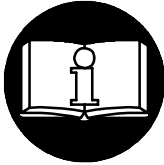

⚠ WARNING

**IMPORTANT SAFETY INFORMATION ENCLOSED.
READ THIS MANUAL BEFORE OPERATING TOOL.**

**IT IS THE RESPONSIBILITY OF THE EMPLOYER TO PLACE THE INFORMATION
IN THIS MANUAL INTO THE HANDS OF THE OPERATOR.**

FAILURE TO OBSERVE THE FOLLOWING WARNINGS COULD RESULT IN INJURY.

PLACING TOOL IN SERVICE

- Always operate, inspect and maintain this tool in accordance with American National Standards Institute Safety Code for Portable Air Tools (ANSI B186.1)
- For safety, top performance, and maximum durability of parts, operate this tool at 90 psig (6.2 bar/620 kPa) maximum air pressure at the inlet with 3/8" (10 mm) inside diameter air supply hose.
- Always turn off the air supply and disconnect the air supply hose before installing, removing or adjusting any accessory on this tool, or before performing any maintenance on this tool.
- Do not use damaged, frayed or deteriorated air hoses and fittings.
- Be sure all hoses and fittings are the correct size and are tightly secured. See Dwg. TPD905-1 for a typical piping arrangement.
- Always use clean, dry air at 90 psig maximum air pressure. Dust, corrosive fumes and/or excessive moisture can ruin the motor of an air tool.
- Do not lubricate tools with flammable or volatile liquids such as kerosene, diesel or jet fuel.
- Do not remove any labels. Replace any damaged label.

USING THE TOOL

- Always wear eye protection when operating or performing maintenance on this tool.

- Always wear hearing protection when operating this tool.
- Keep hands, loose clothing and long hair away from impacting end of tool.
- Anticipate and be alert for sudden changes in motion during start up and operation of any power tool.
- Keep body stance balanced and firm. Do not overreach when operating this tool. High reaction torques can occur at or below the recommended air pressure.
- Tool accessory may continue to impact briefly after throttle is released.
- Air powered tools can vibrate in use. Vibration, repetitive motions or uncomfortable positions may be harmful to your hands and arms. Stop using any tool if discomfort, tingling feeling or pain occurs. Seek medical advice before resuming use.
- Use accessories recommended by Ingersoll-Rand.
- Never operate a Percussion Tool unless an accessory is properly installed and the tool is held firmly against the work.
- Always use a retainer, when furnished, in addition to proper barriers to protect persons in surrounding or lower areas from possible ejected accessories.
- This tool is not designed for working in explosive atmospheres.
- This tool is not insulated against electric shock.

NOTICE

The use of other than genuine Ingersoll-Rand replacement parts may result in safety hazards, decreased tool performance, and increased maintenance, and may invalidate all warranties.

Repairs should be made only by authorized trained personnel. Consult your nearest Ingersoll-Rand Authorized Servicenter.

Refer All Communications to the Nearest
Ingersoll-Rand Office or Distributor.

© Ingersoll-Rand Company 1996

Printed in U.S.A.

INGERSOLL-RAND®
PROFESSIONAL TOOLS

WARNING LABEL IDENTIFICATION



FAILURE TO OBSERVE THE FOLLOWING WARNINGS COULD RESULT IN INJURY.

	<p>⚠ WARNING</p> <p>Always wear eye protection when operating or performing maintenance on this tool.</p>
--	--

	<p>⚠ WARNING</p> <p>Always wear hearing protection when operating this tool.</p>
--	---

	<p>⚠ WARNING</p> <p>Always turn off the air supply and disconnect the air supply hose before installing, removing or adjusting any accessory on this tool, or before performing any maintenance on this tool.</p>
--	--

	<p>⚠ WARNING</p> <p>Air powered tools can vibrate in use. Vibration, repetitive motions or uncomfortable positions may be harmful to your hands and arms. Stop using any tool if discomfort, tingling feeling or pain occurs. Seek medical advice before resuming use.</p>
--	---

	<p>⚠ WARNING</p> <p>Do not carry the tool by the hose.</p>
--	---

	<p>⚠ WARNING</p> <p>Do not use damaged, frayed or deteriorated air hoses and fittings.</p>
--	---

	<p>⚠ WARNING</p> <p>Keep body stance balanced and firm. Do not overreach when operating this tool.</p>
--	---

	<p>⚠ WARNING</p> <p>Operate at 90 psig (6.2 bar/620 kPa) Maximum air pressure.</p>
--	---

<p>International Warning Label: Order Part No. _____</p>	

PERCUSSIVE TOOL SPECIFIC WARNINGS

- When wearing gloves and operating models with inside trigger, always be sure that the gloves will not prevent the trigger from being released.
- Wear safety shoes, hard hat, safety goggles, gloves, dustmask and any other appropriate protective clothing while operating the tool.
- Do not indulge in horseplay. Distraction can cause accidents.
- Keep hands and fingers away from the throttle lever until it is time to operate the tool.
- Never rest the tool or chisel on your foot.
- Never point the tool at anyone.
- Compressed air is dangerous. Never point an air hose at yourself or co-workers.
- Never blow clothes free of dust with compressed air.
- Be sure all hose connections are tight. A loose hose not only leaks but can come completely off the tool and while whipping under pressure, can injure the operator and others in the area. Attach safety cables to all hoses to prevent injury in case a hose is accidentally broken.
- Never disconnect a pressurized air hose. Always turn off the air supply and bleed the tool before disconnecting a hose.
- The operator must keep limbs and body clear of the chisel. If a chisel breaks, the tool with the broken chisel projecting from the tool will suddenly surge forward.
- Do not ride the tool with one leg over the handle. Injury can result if the chisel breaks while riding the tool.
- Know what is underneath the material being worked. Be alert for hidden water, gas, sewer, telephone or electric lines.
- Use only proper cleaning solvents to clean parts. Use only cleaning solvents which meet current safety and health standards. Use cleaning solvents in a well ventilated area.
- Do not flush the tool or clean any parts with diesel fuel. Diesel fuel residue will ignite in the tool when the tool is operated, causing damage to internal parts. When using models with outside triggers or throttle levers, take care when setting the tool down to prevent accidental operation.
- Do not operate the tool with broken or damaged parts.
- Never start the tool when it is lying on the ground.
- This tool is not designed for working in explosive atmospheres.
- This tool is not insulated against electric shock.

PLACING TOOL IN SERVICE

Clean the coating of rust-resisting oil from the exterior of the tool.

Pour about 3 cc of a clean, suitable, cleaning solution into the air inlet. Attach the air hose and run the tool for about 15 seconds. Remove the air hose and pour about 9 cc of Ingersoll-Rand No. 10 Oil into the air inlet.

Immediately operate the tool for about 30 seconds to allow the oil to lubricate the parts.

LUBRICATION



Ingersoll-Rand No. 10 Ingersoll-Rand No. 28

Always use an air line lubricator. We recommend the following Filter-Lubricator-Regulator Unit:

For intermittent use:

For USA - No. 3LUB8

For International - No. 3LUB8

For constant use:

For USA - No. 6LUB12

For International - No. 6LUB12

For Model 241 only - Periodically, or as experience indicates, remove the Oil Chamber Plug and fill the oil chamber with the recommended oil.

After each eight hours of operation, or as experience indicates, use Grease Gun R000A2-228 to inject about 1.5 cc (4 - 6 strokes from the Grease Gun) of Ingersoll-Rand No. 28 Grease into the Grease Fitting.

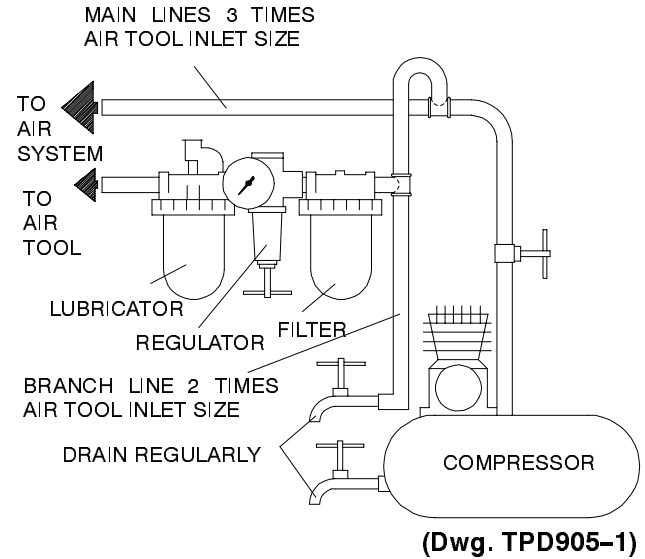

HOW TO ORDER A RAMMER

BENCH TYPE, LEVER THROTTLE

Model	Blows/min.	Piston Stroke	
		in	mm
130A1M	870	2.5	63

FLOOR TYPE, LEVER THROTTLE

241A1M	1 590	4	102
--------	-------	---	-----

MANUEL D'EXPLOITATION ET D'ENTRETIEN FOULOIRS MODÈLES 130A1M ET 241A1M

NOTICE

Le Fouloir Modèle 130 est destiné au compactage du sable des moules et des modèles d'établi dans les applications de fonderie. Le fouloir Modèle 241 est destiné au compactage du sable des moules et des modèles au sol dans les applications de fonderie et au damage des remblayages dans les applications de construction.

Ingersoll-Rand ne peut être tenu responsable de la modification des outils par le client pour les adapter à des applications qui n'ont pas été approuvées par Ingersoll-Rand.

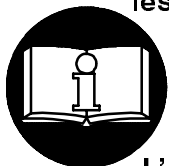

⚠ WARNING

**D'IMPORTANTES INFORMATIONS DE SÉCURITÉ SONT JOINTES.
LIRE CE MANUEL AVANT D'UTILISER L'OUTIL.**

**L'EMPLOYEUR EST TENU À COMMUNIQUER LES INFORMATIONS DE CE MANUEL AUX
EMPLOYÉS UTILISANT CET OUTIL.**

LE NON RESPECT DES AVERTISSEMENTS SUIVANTS PEUT CAUSER DES BLESSURES

MISE EN SERVICE DE L'OUTIL

- Toujours exploiter, inspecter et entretenir cet outil conformément au Code de sécurité des outils pneumatiques portatifs de l'American National Standards Institute (ANSI B186.1).
- Pour la sécurité, les performances optimales et la durabilité maximale des pièces, cet outil doit être connecté à une alimentation d'air comprimé de 6,2 bar (620 kPa) maximum à l'entrée, avec un flexible de 10 mm de diamètre intérieur.
- Couper toujours l'alimentation d'air comprimé et débrancher le flexible d'alimentation avant d'installer, déposer ou ajuster tout accessoire sur cet outil, ou d'entreprendre une opération d'entretien quelconque sur l'outil.
- Ne pas utiliser des flexibles ou des raccords endommagés, effilochés ou détériorés.
- S'assurer que tous les flexibles et les raccords sont correctement dimensionnés et bien serrés. Voir Plan TPD905-1 pour un exemple type d'agencement des tuyauteries.
- Utiliser toujours de l'air sec et propre à une pression maximum de 6,2 bar. La poussière, les fumées corrosives et/ou une humidité excessive peuvent endommager le moteur d'un outil pneumatique.
- Ne jamais lubrifier les outils avec des liquides inflammables ou volatils tels que le kérosène, le gasol ou le carburant d'aviation.
- Ne retirer aucune étiquette. Remplacer toute étiquette endommagée.

UTILISATION DE L'OUTIL

- Porter toujours des lunettes de protection pendant l'utilisation et l'entretien de cet outil.

- Porter toujours une protection acoustique pendant l'utilisation de cet outil.
- Tenir les mains, les vêtements flous et les cheveux longs, éloignés de l'extrémité percutante de l'outil.
- Prévoir, et ne pas oublier, que tout outilmotorisé est susceptible d'à-coups brusques lors de sa mise en marche et pendant son utilisation.
- Garder une position équilibrée et ferme. Ne pas se pencher trop en avant pendant l'utilisation de cet outil. Des couples de réaction élevés peuvent se produire à, ou en dessous, de la pression d'air recommandée.
- La percussion des accessoires de l'outil peut continuer pendant un certain temps après le relâchement de la gâchette.
- Les outils pneumatiques peuvent vibrer pendant l'exploitation. Les vibrations, les mouvements répétitifs et les positions inconfortables peuvent causer des douleurs dans les mains et les bras. N'utiliser plus d'outils en cas d'inconfort, de picotements ou de douleurs. Consulter un médecin avant de recommencer à utiliser l'outil.
- Utiliser les accessoires recommandés par Ingersoll-Rand.
- Ne jamais mettre en marche un outil à percussion à moins qu'un accessoire soit correctement installé et que l'outil soit maintenu fermement contre la pièce à travailler.
- Utiliser toujours une douille de retenue, lorsque fournie, en plus des protections habituelles pour la sécurité du personnel travaillant dans les zones environnantes contre l'éjection possible des accessoires.
- Cet outil n'est pas conçu pour fonctionner dans des atmosphères explosives.
- Cet outil n'est pas isolé contre les chocs électriques.

NOTICE

L'utilisation de rechanges autres que les pièces d'origine Ingersoll-Rand peut causer des risques d'insécurité, réduire les performances de l'outil et augmenter l'entretien, et peut annuler toutes les garanties.

Les réparations ne doivent être effectuées que par des réparateurs qualifiés autorisés. Consultez votre Centre de Service Ingersoll-Rand le plus proche.

Refer All Communications to the Nearest
© Ingersoll-Rand Company 1996









Imprimé aux É.U.

INGERSOLL-RAND®
PROFESSIONAL TOOLS

SIGNIFICATION DES ETIQUETTES D'AVERTISSEMENT

⚠ WARNING

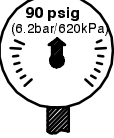
LE NON RESPECT DES AVERTISSEMENTS SUIVANTS PEUT CAUSER DES BLESSURES

	⚠ ATTENTION Porter toujours des lunettes de protection pendant l'utilisation et l'entretien de cet outil.		⚠ ATTENTION Porter toujours une protection acoustique pendant l'utilisation de cet outil.		⚠ ATTENTION Couper toujours l'alimentation d'air comprimé et débrancher le flexible d'alimentation avant d'installer, déposer ou ajuster tout accessoire sur cet outil, ou d'entreprendre une opération d'entretien quelconque sur l'outil.
	⚠ ATTENTION Les outils pneumatiques peuvent vibrer pendant l'exploitation. Les vibrations, les mouvements répétitifs et les positions inconfortables peuvent causer des douleurs dans les mains et les bras. N'utiliser plus d'outils en cas d'inconfort, de picotements ou de douleurs. Consulter un médecin avant de recommencer à utiliser l'outil.		⚠ ATTENTION Ne pas transporter l'outil par son flexible.		⚠ ATTENTION Ne pas utiliser des flexibles ou des raccords endommagés, effilochés ou détériorés.
	⚠ ATTENTION Garder une position équilibrée et ferme. Ne pas se pencher trop en avant pendant l'utilisation de cet outil.		⚠ ATTENTION Utiliser de l'air comprimé à une pression maximum de 6,2 bar (620 kPa).	Étiquette d'avertissement internationale: Commander Pièce No. _____ 	

AVERTISSEMENTS SPÉCIFIQUES AUX OUTILS À PERCUSSION

- Lorsque vous portez des gants et que vous utilisez un outil à gâchette intérieure, vérifiez toujours que les gants n'empêcheront pas le relâchement de la gâchette.
- Lorsque vous utilisez cet outil, portez des chaussures de sécurité, un casque, des lunettes de sécurité, des gants, un masque et tout autre vêtement de protection approprié.
- Ne jouez pas avec l'outil. Toute distraction peut causer un accident.
- Tenez vos mains et vos doigts éloignés du levier de commande lorsque vous n'utilisez pas l'outil.
- Ne posez jamais l'outil sur vos pieds.
- Ne pointez jamais l'outil vers quelqu'un.
- L'air comprimé est dangereux. Ne pointez jamais un flexible d'air comprimé sur vous ou vos collègues.
- Ne nettoyez jamais la poussière de vos vêtements avec un jet d'air comprimé.
- Vérifiez le serrage de toutes les connexions d'air comprimé. Un flexible desserré peut non seulement fuir mais aussi se détacher complètement de l'outil et l'effet de fouet causé par la pression peut blesser l'opérateur ou d'autres personnes à proximité. Attacher des câbles de sécurité sur le flexible pour empêcher toute blessure au cas où le flexible serait accidentellement coupé.
- Ne débranchez jamais un flexible sous pression. Coupez toujours l'alimentation d'air comprimé et purgez l'outil avant de débrancher un flexible.
- Tenez vos bras et vos jambes éloignés du burin. En cas de rupture du burin, l'outil et le reste du burin seront violemment projetés vers l'avant.
- Ne montez jamais sur l'outil avec une jambe par dessus la poignée. La rupture du burin pourrait vous blesser.
- N'oubliez pas que des dangers peuvent se trouver sous la surface où vous travaillez. Prenez soin de ne pas couper des tuyaux d'eau, de gaz ou d'égoût, des câbles électriques ou de téléphone.
- N'utilisez que des solvants de nettoyage appropriés pour nettoyer les pièces. Utilisez seulement les solvants répondant aux réglementations de santé et de sécurité en vigueur, et dans une zone bien aérée.
- Ne rincez jamais l'outil ou les pièces dans du gazole. Les résidus de gazole pourraient s'enflammer dans l'outil lors de sa mise en marche et causer l'endommagement des pièces internes. Lorsque vous utilisez des modèles à gâchette extérieure ou à levier de commande, posez soigneusement l'outil pour empêcher toute mise en marche accidentelle.
- N'utilisez jamais un outil ayant des pièces cassées ou endommagées.
- Ne mettez jamais l'outil en marche lorsqu'il est posé au sol.
- Cet outil n'est pas conçu pour fonctionner dans des atmosphères explosives.
- Cet outil n'est pas isolé contre les chocs électriques.

MISE EN SERVICE DE L'OUTIL

Nettoyer la couche d'huile anti-corrosion de l'extérieur de l'outil.

Verser environ 3 cm³ de solution de nettoyage dans l'orifice d'admission d'air. Brancher le flexible d'alimentation et faire tourner l'outil pendant 15 secondes environ. Débrancher le flexible et verser 9 cm³ d'huile Ingersoll-Rand No. 10 dans le raccord d'admission.

Immédiatement après, faire tourner l'outil pendant 30 secondes pour que l'huile lubrifie toutes les pièces.

LUBRIFICATION



Ingersoll-Rand No. 10



Ingersoll-Rand No. 28

Utiliser toujours un lubrificateur. Nous recommandons l'emploi du filtre-régulateur-lubrificateur suivant :

For USA - No. 3LUB8

Pour usage intermittent : No. 3LUB8

For USA - No. 6LUB12

Pour usage intermittent : No. 3LUB8

Pour usage continu : No. 6LUB12

Seulement pour Modèle 241 – Périodiquement, ou en fonction de l'expérience, déposer le bouchon de la chambre d'huile et remplir cette dernière avec l'huile recommandée.

Toutes les huit heures de fonctionnement, ou en fonction de l'expérience, injecter à l'aide du pistolet de graissage R000A2-228 1,5 cm³ (4 à 6 coups) de graisse Ingersoll-Rand No. 28 dans le raccord de graissage.

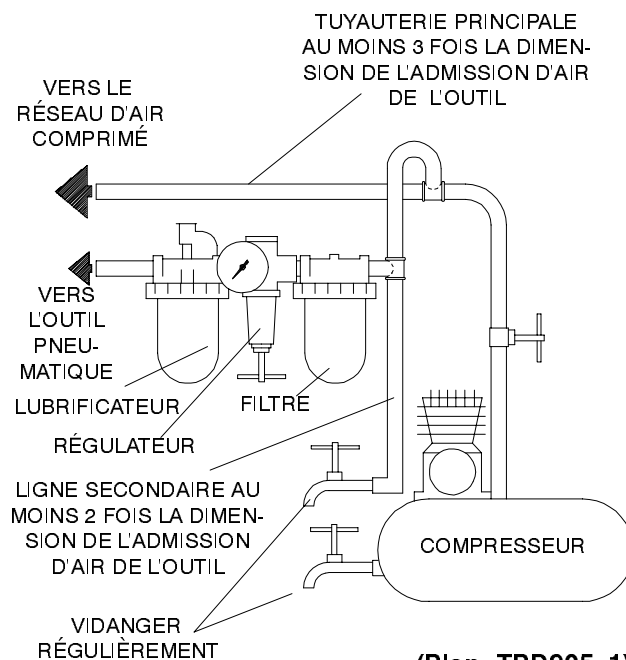

MANUAL DE FUNCIONAMIENTO Y MANTENIMIENTO APISONADORAS MODELO 130A1M Y 241A1M

NOTICE

La Apisonadora de Arena Modelo 130 está diseñada para usar en fundiciones para el compactado de arena en moldes y patrones de nivel de banco de trabajo. La Apisonadora de Arena Modelo 241 está diseñada para usar en fundiciones para el compactado de arena en moldes y patrones de nivel de suelo y para apisonar rellenos en aplicaciones de construcción.

Ingersoll-Rand no aceptará responsabilidad alguna por modificación de las herramientas efectuada por el cliente para aquellas aplicaciones que no hayan sido objeto de consulta con Ingersoll-Rand.

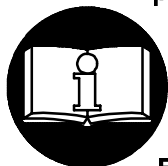

⚠ WARNING

SE ADJUNTA INFORMACION IMPORTANTE DE SEGURIDAD.

LEA ESTE MANUAL ANTES DE USAR LA HERRAMIENTA.

ES LA RESPONSABILIDAD DE CADA EMPLEADOR ASEGURARSE DE QUE EL OPERARIO ESTÉ AL TANTO DE LA INFORMACIÓN QUE CONTIENE ESTE MANUAL. EL HACER CASO OMISO DE LAS ADVERTENCIAS SIGUIENTES PODRIA OCASIONAR LESIONES.

PARA PONER LA HERRAMIENTA EN SERVICIO

- Utilice, examine y mantenga siempre esta herramienta conforme al código de seguridad para herramientas neumáticas portátiles de la American National Standards Institute (ANSI B186.1).
- Para seguridad, máximo rendimiento y durabilidad de piezas, use esta herramienta a una máxima presión de aire de 90 psig (6,2 barías/620kPa) en la admisión de manguera de suministro de aire de diámetro interno de 3/8" (10 mm).
- Cortar siempre el suministro de aire y desconectar la manguera de suministro de aire antes de instalar, retirar, o ajustar cualquier accesorio de esta herramienta, antes de realizar cualquier operación de mantenimiento de la misma.
- No utilizar mangueras de aire y accesorios dañados, desgastados ni deteriorados.
- Asegurarse de que todas las mangueras y los accesorios sean del tamaño correcto y que estén bien apretados. Vea eq. TPD905-1 para un típico arreglo de tuberías.
- Use siempre aire limpio y seco a una máxima presión de 90 psig. El polvo, los vapores corrosivos y/o el exceso de humedad podrían estropear el motor de una herramienta neumática.
- No lubricar las herramientas con líquidos inflamables o volátiles tales como queroseno, gasoil o carburreactor.
- No saque ninguna etiqueta. Sustituir toda etiqueta dañada.

USO DE HERRAMIENTA

- Usar siempre protección ocular al manejar o realizar operaciones de mantenimiento en esta herramienta.

NOTICE

El uso de piezas que no sean recambios genuinos Ingersoll-Rand puede resultar en peligro de seguridad, menor rendimiento de herramienta, e incremento de mantenimiento, esto puede invalidar toda garantía.

La reparaciones deberán solamente ser hechas por personal cualificado y autorizado. Consulte su Centro de Servicio Autorizado Ingersoll-Rand más cercano.

Refer All Communications to the Nearest
© Ingersoll-Rand Company 1996

Impreso en EE. UU.

INGERSOLL-RAND®
PROFESSIONAL TOOLS

ETIQUETAS DE ADVERTENCIA

! WARNING

EL HACER CASO OMISO DE LAS ADVERTENCIAS SIGUIENTES PODRIA OCASIONAR LESIONES.

	<p>! ADVERTENCIA</p> <p>Usar siempre protección ocular al manejar o realizar operaciones de mantenimiento en esta herramienta.</p>
---	---

	<p>! ADVERTENCIA</p> <p>Usar siempre protección para los oídos al manejar esta herramienta.</p>
---	--

	<p>! ADVERTENCIA</p> <p>Cortar siempre el suministro de aire y desconectar la manguera de suministro de aire antes de instalar, retirar o ajustar cualquier accesorio de esta herramienta, o antes de realizar cualquier operación de mantenimiento de la misma.</p>
---	---



	<p>! ADVERTENCIA</p> <p>Las herramientas neumáticas pueden vibrar durante el uso. La vibración, los movimientos repetitivos o las posiciones incómodas podrían dañarle los brazos y las manos. En caso de incomodidad, sensación de hormigueo o dolor, dejar de usar la herramienta. Consultar al médico antes de volver a utilizarla.</p>
---	---

	<p>! ADVERTENCIA</p> <p>No coger la herramienta por la manguera para levantarla.</p>
---	---

	<p>! ADVERTENCIA</p> <p>No utilizar mangueras de aire y accesorios dañados, desgastados ni deteriorados.</p>
---	---

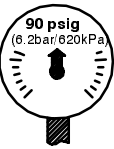
	<p>! ADVERTENCIA</p> <p>Mantener una postura del cuerpo equilibrada y firme. No estirar demasiado los brazos al manejar la herramienta.</p>
---	--

	<p>! ADVERTENCIA</p> <p>Manejar la herramienta a una presión de aire máxima de 90 psig (6,2 barías/620 kPa).</p>
---	---

<p>Etiqueta de Aviso Internacional: Pida Pieza No. _____</p>		
		

AVISOS ESPECÍFICOS PARA HERRAMIENTAS DE PERCUSIÓN

- Cuando use guantes y trabaje con los modelos de gatillo interno, asegúrese siempre que los guantes no evitan que se suelte el gatillo.
- Utilice calzado de seguridad, casco protector, gafas de seguridad, guantes, máscara contra polvo y cualquier otra vestimenta protectora apropiada cuando use esta herramienta.
- No juegue. La distracción puede causar accidentes.
- Mantenga sus manos y dedos fuera de la palanca de mando hasta que esté preparado para usar la herramienta.
- No apoye nunca la herramienta o su cincel sobre el pie.
- No apunte nunca la herramienta a nadie.
- El aire comprimido es peligroso. No apunte nunca la manguera de aire hacia usted o sus compañeros. No quite nunca el polvo de su ropa con aire comprimido.
- Asegúrese que las conexiones de aire estén bien apretadas. Una manguera floja no solamente pierde aire sino que puede salirse completamente de la herramienta y sus latigazos, mientras tenga presión, pueden herir al operario y a otros que se encuentren en esa zona. Ponga cables de seguridad a todas las mangueras por si se rompen accidentalmente.
- No desconecte nunca una manguera de aire con presión. Desconecte siempre el suministro de aire y purgue la herramienta antes de desconectar una manguera.
- El operario debe mantener su cuerpo y miembros a distancia del cincel. Si se rompe el cincel, la herramienta con el cincel roto proyectando de la herramienta saltará adelante repentinamente.
- No se siente sobre la herramienta con una pierna por encima de la empuñadura. Puede causarle daño si se rompe el cincel mientras está sentado sobre la empuñadura.
- Conozca lo que hay debajo del material que está trabajando. Esté alerta por si hay escondidas conducciones de agua, gas, alcantarillado, teléfono o suministro eléctrico.
- Use solamente los disolventes apropiados para la limpieza de las piezas. Use solamente los disolventes de limpieza que cumplan las normas actuales de salud y seguridad. Use los disolventes de limpieza en una zona bien ventilada.
- No limpie la herramienta ni ninguna de sus piezas con gasoil. Los residuos del gasoil se inflamarán en la herramienta cuando se use, dañando así las piezas internas.
- Cuando use modelos con gatillos o palancas de mando externos, tenga cuidado cuando descansa la herramienta para evitar que se ponga en marcha accidentalmente.
- No use la herramienta con piezas rotas o dañadas.
- No ponga en marcha nunca la herramienta cuando esté tumbada sobre el suelo.
- Esta herramienta no ha sido diseñada para trabajar en ambientes explosivos.
- Esta herramienta no está aislada contra descargas eléctricas.

PARA PONER LA HERRAMIENTA EN SERVICIO

Limpie la capa de aceite contra óxido en el exterior de la herramienta.

Ponga así como unos 3 cc de una solución de limpieza apropiada en la admisión de aire. Conecte la manguera de aire y funcione la herramienta por unos 15 segundos. Saque la manguera de aire y ponga así como unos 9 cc de Aceite Ingersoll-Rand N° 10 en la admisión de aire.

Ponga la herramienta en marcha **inmediatamente** por unos 30 segundos para permitir que el aceite lubrique todas las piezas.

LUBRICACION



Ingersoll-Rand N° 10



Ingersoll-Rand N° 28

Use siempre un lubricante de aire. Recomendamos la siguiente Unidad Reguladora-Lubricadora-Filtradora:

Para uso intermitente:

For USA - No. 6LUB8

Internacional - N° 3LUB8

Para uso Constante:

For USA - No. 6LUB12

Internacional - N° 6LUB12

Sólo para Modelo 241— Periódicamente, o como indique la experiencia, saque el Tapón de Cámara de Aceite y llene la cámara de aceite con aceite recomendado.

Después de cada ocho horas de funcionamiento, o como indique la experiencia, use la Pistola Engrasadora R000A2-228 para inyectar así como 1.5 cc (4-6 disparos) de la grasa Ingersoll-Rand No 28 en el engrasador.

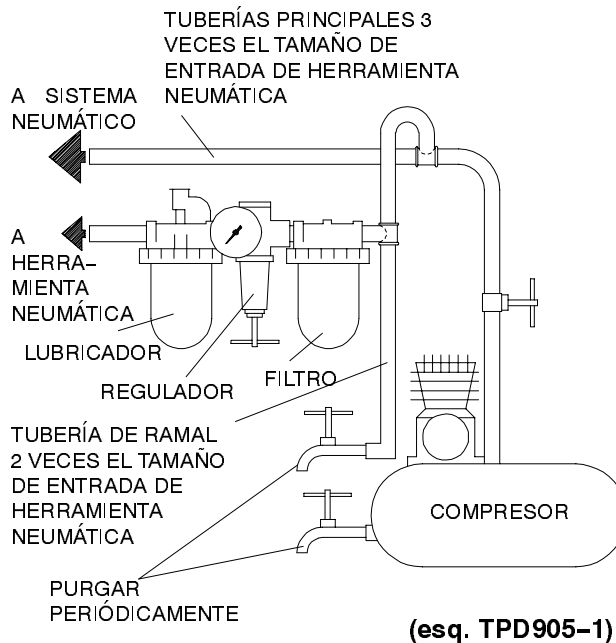

MANUAL DE FUNCIONAMENTO E MANUTENÇÃO BATES ESTACAS MODELOS 130A1M e 241A1M

P

AVISO

O Bate Estaca Modelo 130A1M é concebido para uso em fundições para compactação de areia em moldes e padrões a nível da bancada.

O Bate Estaca Modelo 241A1M é concebido para uso em fundições para compactação de areia em moldes e padrões a nível do solo e batimento de enchimento em aplicações de construção.

A Ingersoll-Rand não é responsável por modificações, feitas pelo cliente em ferramentas, nas quais a Ingersoll-Rand não tenha sido consultada.

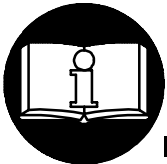

⚠️ ADVERTÊNCIA

**INFORMAÇÃO DE SEGURANÇA IMPORTANTE EM ANEXO.
LEIA ESTE MANUAL ANTES DE OPERAR A FERRAMENTA.**

**É DA RESPONSABILIDADE DO EMPREGADOR COLOCAR A INFORMAÇÃO
DESTE MANUAL NAS MÃOS DO OPERADOR.**

**O NÃO CUMPRIMENTO DAS SEGUINTE ADVERTÊNCIAS PODE RESULTAR EM FERIMENTOS.
COLOCANDO A FERRAMENTA
EM FUNCIONAMENTO**

- Opere, inspeccione e mantenha sempre esta ferramenta de acordo com todas regulamentações (local, estadual, federal e do país), que possam ser aplicadas às ferramentas pneumáticas operadas manualmente ou seguras com as mãos.
- Para segurança, máximo desempenho e máxima durabilidade das peças, opere esta ferramenta com uma pressão de ar máxima de 6,2 bar/620 kPa (90 psig) na entrada da mangueira de alimentação de ar com diâmetro interno de 10mm (3/8 pol).
- Desligue sempre a alimentação de ar e desconecte a mangueira de alimentação de ar antes de instalar, remover ou ajustar qualquer acessório nesta ferramenta, ou antes de executar qualquer serviço de manutenção nesta ferramenta.
- Não use mangueiras de ar ou adaptadores danificados, gastos ou deteriorados.
- Certifique-se de que todas as mangueiras e adaptadores sejam do tamanho correcto e estejam apertados com firmeza. Veja o Desenho TPD905-1 para um arranjo típico de tubagem.
- Use sempre ar seco e limpo com pressão máxima de 90 psig. Pó, fumos corrosivos e/ou humidade excessiva podem arruinar o motor de uma ferramenta pneumática.
- Não lubrifique as ferramentas com líquidos inflamáveis ou voláteis tais como querosene, diesel ou combustível de jactos.
- Não remova nenhum rótulo. Reponha qualquer rótulo danificado.

USANDO A FERRAMENTA

- Use sempre óculos de protecção quando estiver

operando ou executando serviço de manutenção nesta ferramenta.

- Use sempre protecção contra ruído ao operar esta ferramenta.
- Mantenha as mãos, partes do vestuário soltas e cabelos compridos afastados da extremidade em rotação.
- Antecipe e esteja alerta a mudanças repentinas no movimento quando ligar e operar qualquer ferramenta motorizada.
- Mantenha a posição do corpo equilibrada e firme. Não exagere quando operar esta ferramenta. Torques de reacção elevados podem ocorrer na ou abaixo da pressão de ar recomendada.
- Os acessórios da ferramenta podem continuar a girar brevemente após a pressão ter sido aliviada.
- Ferramentas accionadas pneumáticamente podem vibrar em uso. Vibração, movimentos repetitivos ou posições desconfortáveis podem ser prejudiciais às mãos e aos braços. Pare de usar a ferramenta caso ocorra algum desconforto, sensação de formigueiro ou dor. Procure assistência médica antes de retornar ao trabalho.
- Use acessórios recomendados pela Ingersoll-Rand.
- Nunca opere uma Ferramenta de Percussão, a menos que um acessório seja apropriadamente instalado e a ferramenta seja segura firmemente contra o trabalho a ser realizado.
- Use sempre um retentor, quando fornecido, além das barreiras adequadas para proteger pessoas acerca ou abaixo das áreas contra possíveis acessórios projectados.
- Esta Ferramenta não foi concebida para trabalhos em atmosferas explosivas.
- Esta Ferramenta não está isolada contra choques eléctricos.

AVISO

O uso de peças de substituição que não sejam genuinamente da Ingersoll-Rand podem resultar em riscos de segurança, diminuição do desempenho da ferramenta, aumento da necessidade de manutenção e pode invalidar todas as garantias.

As reparações devem ser feitas somente por pessoal treinado autorizado. Consulte o Centro de Serviços da Ingersoll-Rand mais próximo.

Envie Todos os Comunicados Para o Distribuidor ou Escritório da Ingersoll-Rand Mais Próximo.

© Ingersoll-Rand Company 1996

Impresso nos E.U.A.

INGERSOLL-RAND®
PROFESSIONAL TOOLS

IDENTIFICAÇÃO DO RÓTULO DE ADVERTÊNCIA

⚠️ ADVERTÊNCIA

O NÃO CUMPRIMENTO DAS SEGUINTE ADVERTÊNCIAS PODE RESULTAR EM FERIMENTOS.

	<p>⚠️ ADVERTÊNCIA</p> <p>Use sempre óculos de protecção quando estiver operando ou executando algum serviço de manutenção nesta ferramenta.</p>
---	--

	<p>⚠️ ADVERTÊNCIA</p> <p>Use sempre protecção contra o ruído ao operar esta ferramenta.</p>
---	--

	<p>⚠️ ADVERTÊNCIA</p> <p>Desligue sempre a alimentação de ar e desconecte a mangueira de alimentação de ar antes de instalar, remover ou ajustar qualquer acessório nesta ferramenta, ou antes de executar algum serviço de manutenção nesta ferramenta.</p>
---	---



	<p>⚠️ ADVERTÊNCIA</p> <p>Ferramentas accionadas pneumáticamente podem vibrar em uso. Vibração, movimentos repetitivos ou posições desconfortáveis podem ser prejudiciais às mãos e aos braços. Pare de usar a ferramenta caso ocorra algum desconforto, sensação de formigamento ou dor. Procure assistência médica antes de retornar ao trabalho.</p>
---	---

	<p>⚠️ ADVERTÊNCIA</p> <p>Não carregue a ferramenta segurando na mangueira.</p>
---	---

	<p>⚠️ ADVERTÊNCIA</p> <p>Não use mangueiras de ar ou adaptadores danificados, gastos ou deteriorados.</p>
---	--

	<p>⚠️ ADVERTÊNCIA</p> <p>Mantenha a posição do corpo equilibrada e firme. Não exagere quando operar esta ferramenta. Torques de reacção elevados podem ocorrer sob a pressão de ar recomendada.</p>
---	--

	<p>⚠️ ADVERTÊNCIA</p> <p>Opere com pressão do ar Máxima de 90-100 psig (6,2-6,9 bar).</p>
---	--

<p>Rótulo de Advertência Internacional No. de Referência para Pedido _____</p>	
	
	

ADVERTÊNCIAS SOBRE A FERRAMENTA DE PERCUSSÃO

- Quando usar luvas e modelos com operação através de gatilho no punho, certifique-se sempre de que as luvas não irão impedir que o gatilho seja liberado.
- Use sapatos de segurança, capacete, safety goggles, luvas, máscara contra pó e qualquer outra vestimenta de protecção adequada quando for operar a ferramenta.
- Não brinque com a ferramenta. A distração pode causar acidentes.
- Mantenha as mãos e dedos fora do alcance da alavanca reguladora de pressão até o momento de operar a ferramenta.
- Nunca descanse a ferramenta ou a barrena sobre o seu pé.
- Nunca aponte a ferramenta para alguém.
- Ar comprimido é perigoso. Nunca aponte um mangueira de ar para si ou colega de trabalho.
- Nunca sobre a suas roupas para tirar o pó com ar comprimido.
- Certifique-se de todas as conexões da mangueira estejam apertadas. Um mangueira não apenas vaza, mas também pode escapar da ferramenta e ricocheteiar enquanto estiver sobre pressão, causando ferimentos ao operador o a pessoas próximas do local de operação da ferramenta. Conecte os cabos de segurança em todas as mangueiras para evitar ferimentos caso uma mangueira se rompa acidentalmente.
- Nunca desconecte uma mangueira de ar pressurizada. Desligue sempre a alimentação de ar e esvazie da ferramenta antes de desligar a mangueira.
- O operador deve manter os membros e o corpo fora do alcance da barrena. Se uma barrena quebrar, a ferramenta e a barrena quebrada irão projectar-se para frente.
- Não conduza a ferramenta com a perna sobre o punho. Um ferimento pode ocorrer se a barrena se quebrar.
- Saiba o que se encontra abaixo do material a ser quebrado. Esteja alerta para condutas escondidas de ar, água, esgoto, telefone e cabos eléctricos.
- Use sómente solventes de limpeza adequados para limpar as peças. Use somente solventes de limpeza que estejam de acordo com as normas de segurança e saúde. Use solventes de limpeza em ambientes bem ventilados.
- Não encharque ou limpe qualquer peça com óleo diesel. O resíduo do óleo diesel irá pegar fogo dentro da ferramenta causando danos às peças internas da ferramenta. Quando usar modelos com gatilhos externos ou alavancas de regulagem de pressão, tome cuidado quando descansar a ferramenta para evitar acidentes de operação.
- Não opere uma ferramenta com peças danificadas ou quebradas.
- Não ligue a ferramenta quando a mesma estiver deitada sobre o chão.
- Esta ferramenta não foi concebida para trabalhos em atmosferas explosivas.
- Esta ferramenta não está isolada contra choque eléctricos.

COLOCANDO A FERRAMENTA EM FUNCIONAMENTO

Limpe o revestimento de óleo de resistência à ferrugem no exterior da ferramenta.

Despeje cerca de 3 cc de solução de limpeza limpa e adequada na entrada de ar. Conecte a mangueira de ar e ponha a ferramenta para funcionar por cerca de 15 segundos. Remova a mangueira de ar e despeje cerca de 9 cc de Óleo Ingersoll-Rand No.10 na entrada de ar.

Imediatamente opere a ferramenta por cerca de 30 segundos para permitir que o óleo lubrifique as peças internas.

LUBRIFICAÇÃO



Ingersoll-Rand No. 10 Ingersoll-Rand No. 28

Use sempre um lubrificador de ar de linha com estas ferramentas. Nós recomendamos a seguinte Unidade Filtro-Lubrificador-Regulador:

For USA - No. 6LUB12

Para uso intermitente:

Para Internacional - No. 3LUB8

For USA - No. 6LUB12

Para uso constante:

Para Internacional - No. 6LUB12

Para Modelos 241 somente - Periódicamente, ou como a experiência indicar, remova o Bujão da Câmara de Óleo e encha-a de óleo com óleo recomendado.

Depois de cada oito horas de operação, ou como a experiência indicar, use o Canhão de Massa R000A2-228 para injectar cerca de 1,5 cc (4 a 6 medidas do Canhão de Massa) de Massa Ingersoll-Rand No. 28 no Adaptador de Massa.

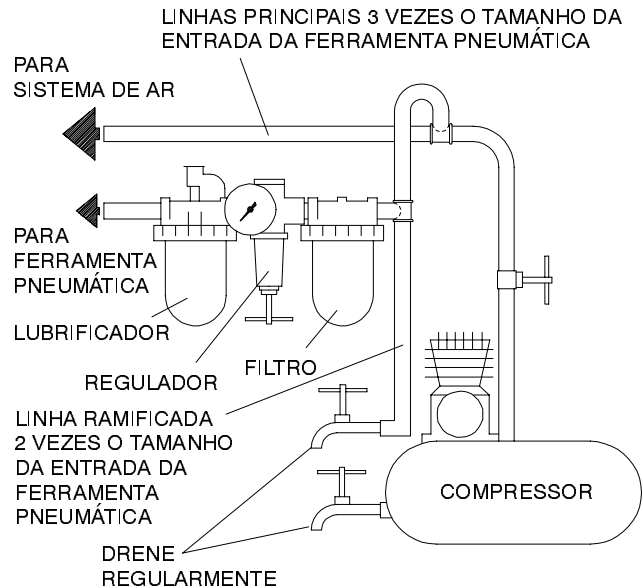

(Desenho TPD905-1)

MODEL 130A1M SAND RAMMER

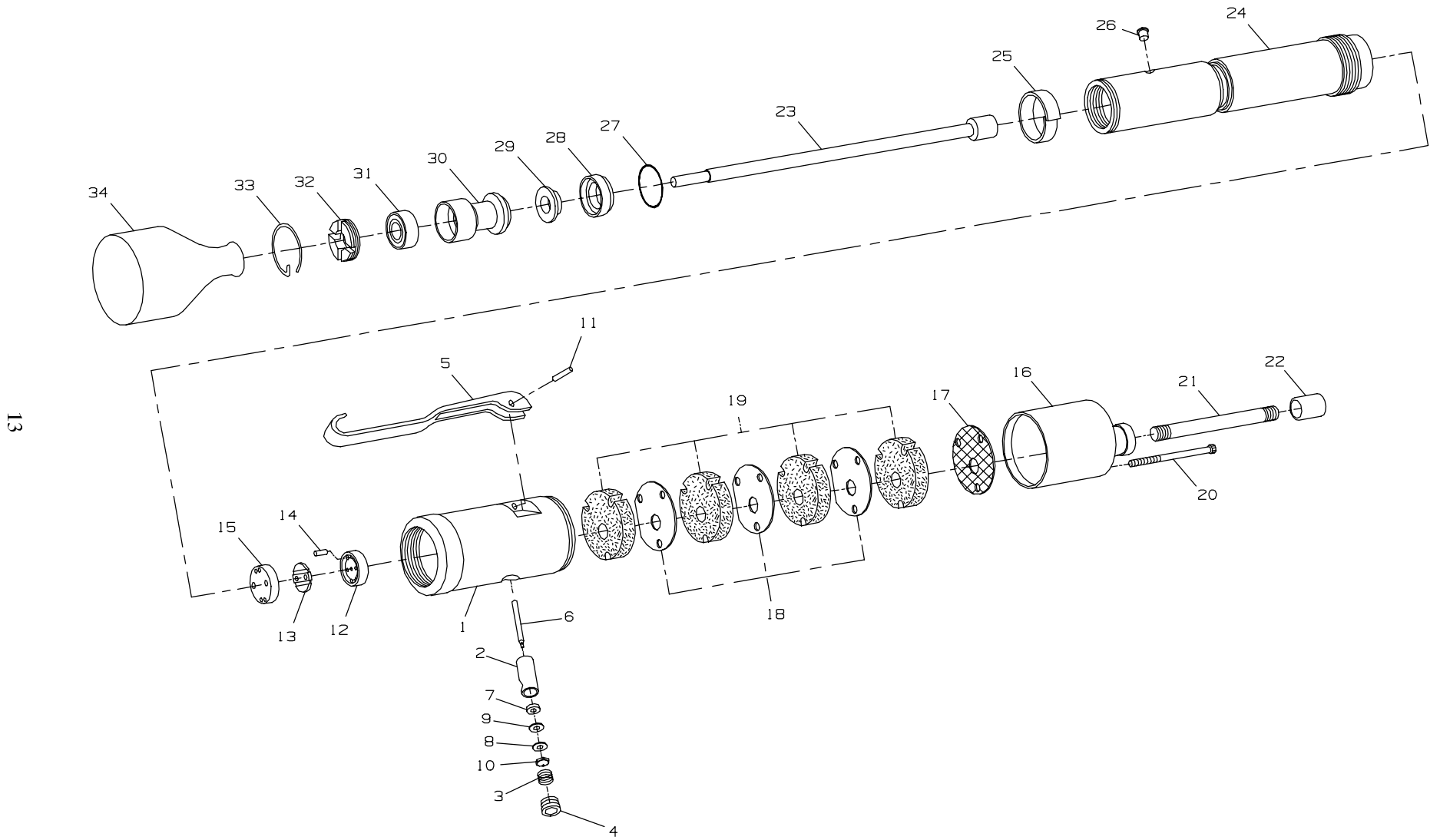

MAINTENANCE SECTION

(Dwg. TPA620)

PART NUMBER FOR ORDERING

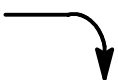

PART NUMBER FOR ORDERING

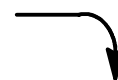

	Head Block Assembly for Built-in Muffler		20	Adapter Screw (3)	12E-354
	for 130A1M	130SR-A114	21	Pipe Nipple (1/4" x 4")	HUS-913
	for 130A1M-EU	130SR-EU-A114	22	Pipe Coupling (1/4")	140SR-117
	Warning Label		23	Piston	130SR-R20
	for 130A1M	WARNING-6-99	24	Barrel	130SR-R10
	for 130A1M-EU	EU-99	25	Barrel Clip	130SR-35
1	Head Block	130SR-114	26	Grease Fitting	130SR-188
2	Throttle Valve Bushing	130SR-503	27	Seal Support Gasket	MT4-210
3	Throttle Valve Spring	AR-51	28	Seal Support	130SR-28
4	Throttle Valve Cap	GA57-95	29	Rod Rear Seal	130SR-30
5	Throttle Lever	130SR-263	30	Piston Rod Guide	130SR-32
6	Throttle Valve	130SR-302	31	Rod Front Seal	130SR-31
7	Throttle Valve Face Washer	130SR-156	32	Guide Retainer	130SR-33
8	Throttle Valve Face Cap	R38-157	33	Guide Retainer Lock	130SR-34
9	Throttle Valve Face	R38-159	34	Malleable Butt (2-1/2" diameter)	12SR-83
10	Throttle Valve Face Cap Nut	AVC11-158	*	Male Hose Nipple	
11	Throttle Lever Pin	D01-368		(3/8" hose to 1/4" male pipe)	D01-14
12	Valve Box Cap	14SR-43	*	Rubber Tipped Butt (2-3/8" diameter)	14SR-83R-2 3/8
13	Valve	14SR-40	*	Rubber Tip for Butt	14SR-84
14	Valve Box Dowel (4)	14SR-45	*	Rubber Tipped Peen (3/4" x 2-3/8")	14SR-93R
15	Valve Box	14SR-41	*	Rubber Topping-Off Butt (3-29/32" diameter)	
16	Piped-Away Exhaust Adapter	140SR-115		(solid rubber with steel insert)	14SR-83R-4
17	Adapter Screen	140SR-122	*	Piston	
18	Adapter Baffle (3)	140SR-116		0.004" oversize	130SR-R20-4
19	Exhaust Silencer (4)	140SR-311		0.016" oversize	130SR-R20-16

* Not illustrated.

**MODEL 241 FLOOR RAMMER
WITH ROUND ROD AND
LUBRICATOR TYPE HEAD BLOCK**

15

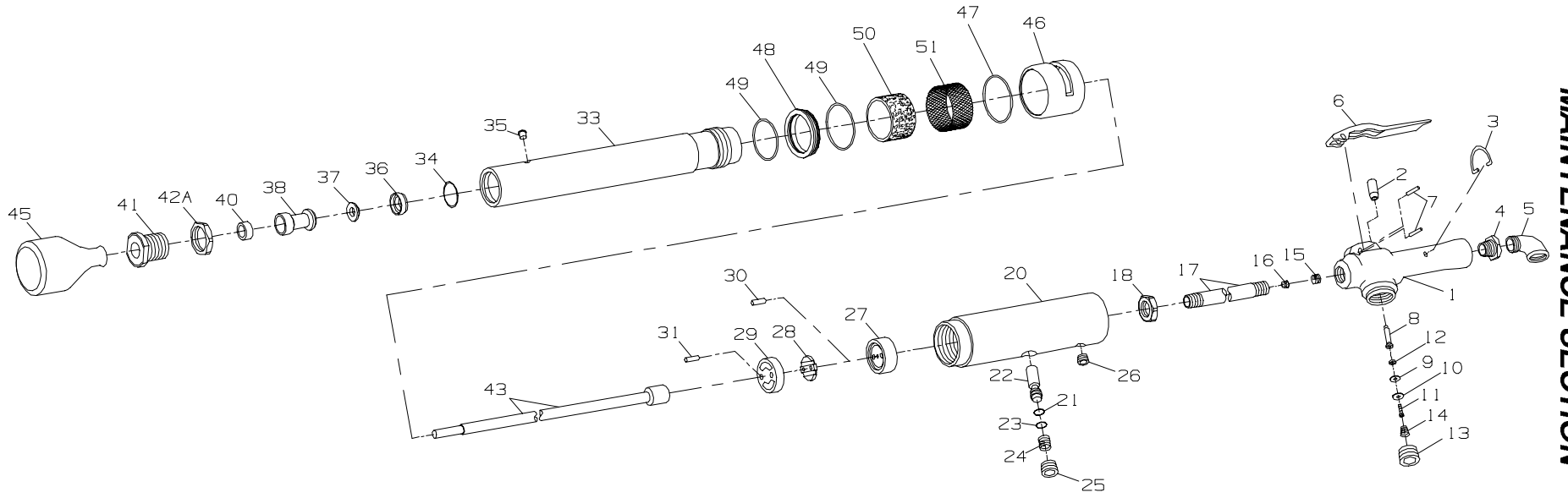

MAINTENANCE SECTION

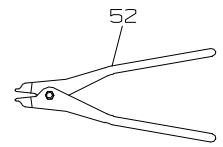

EXHAUST DEFLECTOR PLIERS

PART NUMBER FOR ORDERING

PART NUMBER FOR ORDERING

	Throttle Handle Assembly for 241A1M	241SR-A160	27	Valve Box Cap	24SR-43
	for 241A1M-EU	241SR-EU-A160	28	Valve	24SR-40
	Warning Label for 241A1M	WARNING-6-99	29	Valve Box	241SR-41
	for 241A1M-EU	EU-99	30	Valve Box Cap Dowel (2)	33SR-45
1	Throttle Handle Body	150SR-160	31	Valve Box Dowel (2)	D01-527
2	Throttle Valve Bushing	150SR-503	33	Barrel for Piston with Round Rod	241SR-R10
3	Throttle Valve Lock Ring	2T-56	• 34	Seal Support Gasket	FMD2-198
4	Reducing Bushing (1/2" to 3/8")	13SR-9	35	Grease Fitting	130SR-188
5	3/8" Street Elbow	12SR-8	• 36	Seal Support	241SR-28
6	Throttle Lever	33SR-163	• 37	Rod Rear Seal	241SR-30
7	Throttle Lever Pin or Throttle Lever Stop Pin (2)	5040T-962	• 38	Piston Rod Guide	241SR-A32A
8	Throttle Valve	150SR-302	40	Rod Front Seal	241SR-31
• 9	Throttle Valve Face	MT4-159	• 41	Guide Retainer	241SR-33A
10	Throttle Valve Face Cap	R4-157	42	Locking Nut	241SR-17
11	Throttle Valve Face Retaining Screw	4U-359	43	Piston with Round Rod Standard Size	241SR-R20
12	Retaining Screw Lock Washer	H54U-352		0.004" Oversize	241SR-R20-4
13	Throttle Valve Cap	DLC-165		0.008" Oversize	241SR-R20-8
14	Throttle Valve Spring	150SR-262		0.016" Oversize	241SR-R20-16
15	Screen Retaining Spring	241SR-5	45	Malleable Butt 3" diameter	22SR-83-3 x 3/4
16	Air Strainer Screen	434-61		Muffler Kit	241SR-K123
17	Handle Standard Length (19-1/2")	34SR-1A	46	Exhaust Deflector Assembly	241SR-A123
	Extra Long (26")	341SR-201	47	Deflector Seal	C6H20A-104
18	Handle Lock Nut	241SR-118	48	Deflector Retainer Assembly	241SR-A124
20	Head Block	241SR-14	49	Deflector Retainer Seal (2)	R10V-310
• 21	Lubricator Valve Seat	R18L-14	50	Exhaust Silencer	241SR-311
22	Lubricator Valve	241SR-101	51	Deflector Screen	241SR-122
23	Lubricator Valve Face	R0AR-210	52	Exhaust Deflector Pliers	34SR-54
24	Lubricator Valve Spring	24SR-106	*	Rubber-Tipped Butt (3" diameter)	24SR-83R-3
25	Lubricator Valve Cap	HH-266	*	Jumbo Rubber Topping off Butt (5" diameter)	24SR-83R-5
26	Oil Chamber Plug	R0H-377			

* Not illustrated.

• To keep downtime to a minimum, it is desirable to have on hand certain repair parts. We recommend that you stock one (pair or set) of each part indicated by a bullet (•) for every four tools in service.

MAINTENANCE TOOLS

TOOL NUMBER FOR ORDERING	TOOL NAME FOR ORDERING	OPERATION
K-27	Throttle Valve Cap Wrench	Installing or removing the Throttle Valve Cap (4) in the Head Block (1).
D32-26	Guide Retainer Wrench	Removing or installing the Guide Retainer (32) in the Barrel (24).
R000A2-228	Grease Gun	Lubrication.

MAINTENANCE SECTION

WARNING

Always wear eye protection when operating or performing maintenance on this tool.

Always turn off air supply and disconnect air supply hose before installing, removing or adjusting any accessory on this tool, or before performing any maintenance on this tool.

LUBRICATION

Each time the Model 130A1M or 241A1M Sand Rammer is disassembled for maintenance, repair or replacement of parts, lubricate the tool as follows:

1. Inject approximately 1.5 cc of recommended grease into the Grease Fitting.
2. Pour about 9 cc of recommended oil into the air inlet and run the tool for about 15 seconds to thoroughly coat the parts.
3. For Model 241 only, remove the Oil Chamber Plug (26) and fill the oil chamber with 9 cc of Ingersoll-Rand No. 10 Oil.

DISASSEMBLY

General Instructions

1. Always wear eye protection when operating or performing maintenance on this tool.
2. Do not disassemble the tool any further than necessary to replace or repair damaged parts.
3. Whenever grasping a tool or part in a vise, always use leather-covered or copper-covered vise jaws to protect the surface of the part and help prevent distortion. This is particularly true of threaded members and housings.
4. Do not remove any part which is a press fit in or on a subassembly unless the removal of that part is necessary for repairs or replacement.
5. Do not disassemble the Percussion Tool unless you have a complete set of new gaskets and O-rings for replacement.

Disassembly of the Throttle Assembly

For Model 130 only

1. Clamp the Head Block (1) in leather-covered or copper-covered vise jaws with the Throttle Lever (5) upward.
2. Drive the Throttle Lever Pin (11) out and remove the Throttle Lever.

3. Rotate the Block in the vise to gain access to the Throttle Valve Cap (4). Unscrew the Throttle Valve Cap and the Throttle Valve Spring (3).
4. Remove the throttle assembly.
5. While holding the Throttle Valve (6) securely, unscrew the Throttle Valve Face Cap Nut (10). Remove the Throttle Valve Face Cap (8), Throttle Valve Face (9), and the Throttle Valve Face Washer (7) from the Throttle Valve.
6. If required, press the Throttle Valve Bushing (2) from the Head Block.

For Model 241 only

1. Clamp the Head Block (20) in leather-covered or copper-covered vise jaws.
2. Loosen the Handle Locknut (18) and unscrew the Handle (17) from the Head Block.
3. Clamp the Handle in leather-covered or copper-covered vise jaws.
4. Unscrew the Throttle Handle Body (1) from the Handle. Remove the Screen Retaining Spring (15) and the Air Strainer Screen (16).
5. Clamp the Throttle Handle Body in leather-covered or copper-covered vise jaws Throttle Lever (6) upward.
6. Drive out the Throttle Lever Pin/Throttle Lever Stop Pin (7) and remove the Throttle Lever.
7. Unscrew the Street Elbow (5). Unscrew the Reducing Bushing (4).
8. Rotate the Throttle Handle Body in the vise to gain access to the Throttle Valve Cap (13).
9. Unscrew the Throttle Valve Cap and remove the Throttle Valve Spring (14).
10. Carefully drive the Throttle Valve (8) out of the Throttle Handle Body through the throttle valve cap bore.
11. Unscrew the Throttle Valve Face Retaining Screw (11) from the Throttle Valve. Remove the Throttle Valve Face Cap (10), the Throttle Valve Face (9), and the Retaining Screw Lock Washer (12).
12. If required, press the Throttle Valve Bushing (2) from the Throttle Handle Body.

Disassembly of the Exhaust Adapter

For Model 130 only

1. Unscrew the Pipe Coupling (22) and the Pipe Nipple (21).

MAINTENANCE SECTION

2. Unscrew the Adapter Screw (20).
3. Remove the Piped-Away Exhaust Adapter (16) from the Head Block (1).
4. Remove the four Exhaust Silencers (19), three Adapter Baffles (18), and the Adapter Screen (17) from the Exhaust Adapter.

Disassembly of the Valve Box Assembly

For Model 130 only

1. Clamp the Barrel (24) in leather-covered or copper-covered vise jaws, Malleable Head (24) downward.
2. Unscrew the Head Block (1) from the Barrel.
3. Remove the Valve Box Cap (12), the Valve (13), and the Valve Box (15).
4. If required, remove the four Valve Box Dowels (14) from the Valve Box Cap.

Disassembly of the Head Block

For Model 241 only

1. Clamp the Barrel (33) in leather-covered or copper-covered vise jaws with the Head Block (20) upward.
2. Using a large wrench, unscrew the Head Block from the Barrel.
3. Remove the Exhaust Deflector Assembly (46), Deflector Retainer Assembly (48), Exhaust Silencer (50) and Deflector Screen (51).
4. Remove the Valve Box Cap (27), Valve (28), Valve Box Cap Dowel (30), Valve Box (29), and the Valve Box Dowels (31).
5. Remove the Lubricator Valve Cap (25) and the Lubricator Valve Spring (24).
6. Carefully push the Lubricator Valve (22) from the Head Block through the lubricator valve cap bore.
7. If required, remove the Lubricator Valve Face (23) from the Lubricator Valve and the Lubricator Valve Seal (21) from the Head Block.

Disassembly of the Barrel

For both Models

1. Clamp the shaft of the Piston (23, 43) in leather-covered or copper-covered vise jaws with the Malleable Butt (34, 45) downward.
2. Using a large hammer, tap the Butt off the Piston.

For Model 130 only

3. Clamp the Barrel (24) in leather-covered or copper-covered vise jaws with the Piston sideways.
4. Pry the Guide Retainer Lock (33) from the groove in the Barrel.
5. Unscrew the Guide Retainer (32).

For Model 241 only

6. Loosen the Locking Nut (42A) and remove the Guide Retainer (41).
7. Gently remove the Piston from the Barrel.

For both Models

8. Gently pull the Piston to remove the Front Rod Seal (31, 40), the Piston Rod Guide (30, 38), the Rod Rear Seal (29, 37), and the Seal Support (28, 36) from the Barrel.
9. Remove the Seal Support Gasket (27).

ASSEMBLY

General Instructions

1. Whenever grasping a tool or part in a vise, always use leather-covered or copper-covered vise jaws. Take extra care with threaded parts and housings.
2. Always clean every part and wipe every part with a thin film of oil before installation.
3. Apply a film of O-ring lubricant to all O-rings before final assembly.

Assembly of the Barrel

For Model 130 only

1. Clamp the Barrel (24) in leather-covered or copper-covered vise jaws with the butt end upward.
2. Place the Piston (23) into the Barrel, big end first.
3. Carefully seat the Seal Support Gasket (27) in the groove in the Barrel.
4. The Seal Support (28) inserted into the Barrel will retain the Seal Support Gasket.
5. Place the Rod Rear Seal (29), small end first, into the Seal Support.
6. With the cup end of the Piston Rod Guide (30) facing the butt end, slide the Piston Rod Guide down the bore until it seats in the Seal Support.
7. Seat the Rod Front Seal (31) into the Piston Guide Rod.
8. Retain the Rod Guide/Sealing Assemblies with the Guide Retainer (32).
9. Snug the Guide Retainer until one of the slots in the Retainer aligns with one of the Guide Retainer Lock holes in the Barrel.
10. Install the Guide Retainer Lock (33) into the groove in the Barrel and through the lock hole.

For Model 241 only

1. If required, reinstall the Seal Support Gasket (34) into the groove in the Barrel (33).
2. Place the Seal Support (36) on the Piston (43). Place the Rod Rear Seal (37) on the Seal Support.
3. Follow the Rear Seal with the Piston Rod Guide (38). Place the Rod Front Seal (40) onto the Piston and into the Rod Guide.
4. Place the Piston and the seal/support assembly into the Barrel.
5. Secure the Piston with the Guide Retainer (41). Lock the Guide Retainer with the Locking Nut (42A).

Assembly of the Valve Box

For Model 130 only

1. Clamp the Barrel (24) in leather-covered or copper-covered vise jaws with the butt end downward.

MAINTENANCE SECTION

2. Place the Valve Box (15) into the Barrel, large diameter down.
3. Place the Valve (13) on the Valve Box.
4. Place the four Valve Box Dowels (14) into the Valve Box through the Valve.
5. Place the Valve Box Cap (12) on the Valve.
6. Secure the valve assembly with the Head Block (1).

Assembly of the Exhaust Adapter

For Model 130 only

1. Place the Adapter Screen (17) into the Piped-Away Exhaust Adapter (16).
2. Ensuring that the holes in the Adapter Baffles (18), the Exhaust Silencers, the Adapter Screen, and the Exhaust Adapter align, alternately insert the Exhaust Silencers and Adapter Baffles into the Exhaust Adapter.
3. While holding the exhaust assembly together, place it on the Head Block (1) and secure it with the Adapter Screws (20).
4. Screw the Pipe Coupling (22) on the Pipe Nipple (21). Place the Pipe Nipple through the Exhaust Adapter and screw it into the Head Block.

Assembly of the Head Block

For Model 241 only

1. Clamp the Barrel (33) in rugged vise jaws with the Butt (45) end down.
2. Install the Deflector Screen (51), Exhaust Silencer (50), Deflector Retainer Assembly (48) and Exhaust Deflector Assembly (46).
3. Carefully place the Valve Box Dowels (31) and the Valve Box (29) on the Barrel.
4. Place the Valve Box Cap Dowels (30) into the Valve Box. Place the Valve (28) and the Valve Box Cap (27) onto the Valve Box.
5. Secure the valve assembly with the Head Block (20). Tighten the Head Block to 500 ft-lb (678 Nm).
6. If required, replace the Lubricator Valve Seal (21) in the groove in the lubricator valve bore.
7. If required, replace the Lubricator Valve Face (23) onto the Lubricator Valve (22).
8. Carefully push the Lubricator Valve into the Head Block.
9. Place the Lubricator Valve Spring onto the Valve and secure the assembly with the Lubricator Valve Cap (25).

Assembly of the Throttle Valve

For Model 130 only

1. If required, press the Throttle Valve Bushing (2) into the Head Block (1) being careful to align the timing marks on the Block.

2. Clamp the Head Block in leather-covered or copper-covered vise jaws with the Throttle Valve Cap hole upward.
3. Place the Throttle Valve Face Washer (7), the Throttle Valve Face (9) Throttle Valve Face Cap (8) onto the Throttle Valve (6). Secure the assembly with the Throttle Valve Face Cap Nut (10).
4. Place the throttle assembly into the Valve Block, throttle valve stem first.
5. Follow the throttle assembly with the Throttle Valve Spring (3) and secure it with the Throttle Valve Cap (4).
6. Turn the Head Block in the vise so that the Throttle Lever can be installed.
7. Place the Throttle Lever on the boss on the Head and secure it with the Throttle Lever Pin (11).

For Model 241 only

1. Clamp the Throttle Handle Body (1) in leather-covered or copper-covered vise jaws with the throttle lever boss upward.
2. Press in the Throttle Lever Pin/Throttle Lever Stop Pin (7) to secure the Throttle Lever (6).
3. Rotate the Throttle Handle Body in the vise.
4. If required, press the Throttle Valve Bushing (2) into the Throttle Handle Body.
5. Place the Retaining Screw Lock Washer (12) on the Throttle Valve (8).
6. Reinstall the Throttle Valve Face (9) and Throttle Valve Face Cap (10) onto the Throttle Valve.
7. Secure the Throttle Valve Face Cap with the Throttle Valve Face Retaining Screw (11).
8. Carefully push the Throttle Valve into the Throttle Handle Body.
9. Place the Throttle Valve Spring (14), small end first, onto the Throttle Valve.
10. Secure the throttle assembly with the Throttle Valve Cap (13).
11. Screw the Reducing Bushing (4) into the Throttle Handle Body and the Street Elbow (5) into the Reducing Bushing.
12. Rotate the Throttle Handle Body in the vise, Elbow downward.
13. Place the Screen Retainer Spring (15) and the Air Strainer Screen (16), convex up, into the Throttle Handle Body.
14. Thread the Handle (17) into the Throttle Handle Body.
15. Run the Handle Locknut (18) to the end of the threads on the Handle.
16. Screw the Handle into the Barrel (20) and tighten the Handle Locknut against the Handle.
17. Place the Malleable Butt (45) onto the Piston (43) and rap the Butt with a large hammer to seat it.