

OPERATION AND MAINTENANCE MANUAL

for

MODEL 599A1 IMPACTOOL

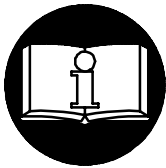
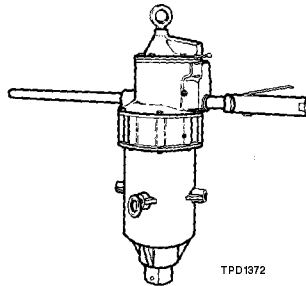

⚠ WARNING

**IMPORTANT SAFETY INFORMATION ENCLOSED.
READ THIS MANUAL BEFORE OPERATING TOOL.**

FAILURE TO OBSERVE THE FOLLOWING WARNINGS COULD RESULT IN INJURY.

- Always operate, inspect and maintain this tool in accordance with American National Standards Institute Safety Code for Portable Air Tools (ANSI B186.1).
- For safety, top performance, and maximum durability of parts, operate this tool at 90 psig (6.2 bar/620 kPa) maximum air pressure at the inlet with 1-1/2" (38 mm) inside diameter air supply hose.
- Air powered tools can vibrate in use. Vibration, repetitive motions or uncomfortable positions may be harmful to your hands and arms. Stop using any tool if discomfort, tingling feeling or pain occurs. Seek medical advice before resuming use.
- Always turn off the air supply and disconnect the air supply hose before installing, removing or adjusting any accessory on this tool, or before performing any maintenance on this tool.
- Keep hands, loose clothing and long hair away from rotating end of tool.
- Anticipate and be alert for sudden changes in motion during start up and operation of any power tool.
- Tool shaft may continue to rotate briefly after throttle is released.
- Do not lubricate tools with flammable or volatile liquids such as kerosene, diesel or jet fuel.
- Do not remove any labels. Replace any damaged label.
- Use accessories recommended by Ingersoll-Rand.
- This tool can exert strong forces on the operator. Use proper support to control these forces.
- This tool is designed to be operated by two persons.
- This tool is not designed for working in explosive atmospheres.
- This tool is not insulated against electric shock.

NOTICE

The use of other than genuine Ingersoll-Rand replacement parts may result in safety hazards, decreased tool performance, and increased maintenance, and may invalidate all warranties.

Ingersoll-Rand is not responsible for customer modification of tools for applications on which Ingersoll-Rand was not consulted.

Repairs should be made only by authorized, trained personnel. Consult your nearest Ingersoll-Rand Authorized Servicenter.

It is the responsibility of the employer to place the information in this manual into the hands of the operator.

Refer All Communications to the Nearest
Ingersoll-Rand Office or Distributor.

© Ingersoll-Rand Company 1995

Printed in U.S.A.

INGERSOLL-RAND®
PROFESSIONAL TOOLS

WARNING LABEL IDENTIFICATION

⚠ WARNING

FAILURE TO OBSERVE THE FOLLOWING WARNINGS COULD RESULT IN INJURY.

	⚠ WARNING
	Always wear eye protection when operating or performing maintenance on this tool.

	⚠ WARNING
	Always wear hearing protection when operating this tool.

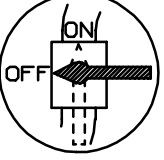
	⚠ WARNING
	Always turn off the air supply and disconnect the air supply hose before installing, removing or adjusting any accessory on this tool, or before performing any maintenance on this tool.

	⚠ WARNING
	Air powered tools can vibrate in use. Vibration, repetitive motions or uncomfortable positions may be harmful to your hands and arms. Stop using any tool if discomfort, tingling feeling or pain occurs. Seek medical advice before resuming use.

	⚠ WARNING
	Do not carry the tool by the hose.

	⚠ WARNING
	Do not use damaged, frayed or deteriorated air hoses and fittings.

	⚠ WARNING
	Keep body stance balanced and firm. Do not overreach when operating this tool.

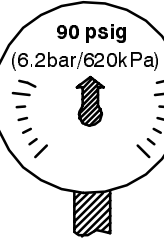
	⚠ WARNING
	Operate at 90 psig (6.2 bar/620 kPa) Maximum air pressure.

PLACING TOOL IN SERVICE

LUBRICATION



Ingersoll-Rand No. 50 Ingersoll-Rand No. 100

Always use an air line lubricator with these tools.
We recommend the following Filter-Lubricator-Regulator Unit:

For USA - No. C31-06-G00

For International - No. FRL30-C6-A29

After each four hours of operation, unless an air line lubricator is used, unscrew any one of the three Oil Chamber Plugs (8) and replenish the chamber in the Motor Housing (1) with Ingersoll-Rand No. 50 Oil.

After each eight hours of operation, insert approximately one ounce of Ingersoll-Rand No. 100 Grease into the Hammer Case (62) through the Grease Fitting (64).

After each forty hours of operation, insert approximately one ounce of Ingersoll-Rand No. 100 Grease into the Gear Case (49) through the Grease Fitting (50).

After each forty hours of operation, or as experience indicates, remove the Hammer Case (62) and check the impact unit for sufficient lubrication. If necessary, coat the hammer jaws and anvil jaws with Ingersoll-Rand No. 100 Grease. Insert about one tablespoonful of this grease into each of the two holes in the side of the Hammer to lubricate the Cam Balls (59) and the Hammer Spring Thrust Bearing (57). Apply a light coat of No. 100 Grease to the shank of the Anvil (61) that rotates in the Hammer Case Bushing (63).

Do not apply grease to the exterior cylindrical surface of the Hammer (55), as this is not a bearing surface. Remove any excess grease that may have accumulated on the inner wall of the Hammer Case (62). An excessive amount of grease may retard the action of the impact unit.

The Model 599A1 Impacttool is designed for large machinery repair, railroad right of way and engine maintenance, power plant maintenance, machinery mounting, pipe line and oil platform maintenance and other fastener applications requiring high torque.

It is recommended that the Impacttool, when not in use, be positioned with the front end down so that the grease will flow forward to the jaws.

INSTALLATION

Air Supply and Connections

Always use clean dry air at 90 psig maximum air pressure. Dust, corrosive fumes and/or excessive moisture can ruin the motor of an air tool. An air line filter can greatly increase the life of an air tool. The filter removes dust and moisture. Be sure all hoses and fittings are the correct size and are tightly secured. See Dwg. TPD905-1 for a typical piping arrangement.

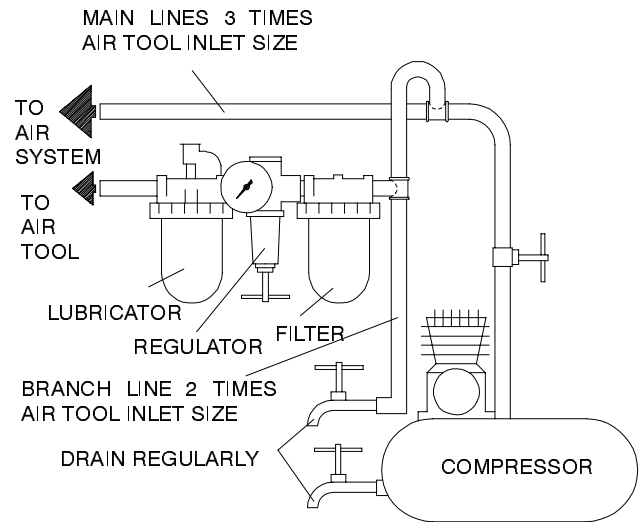

(Dwg. TPD905-1)

HOW TO ORDER AN IMPACTTOOL

LEVER HANDLE WITH 3-1/2" SQUARE DRIVE

Model	Impacts/min.	Recommended Torque Range	
		ft-lb	Nm
599A1	500	26 000 - 42 000	35 250 - 57 000

SIZE 599 IMPACTTOOL

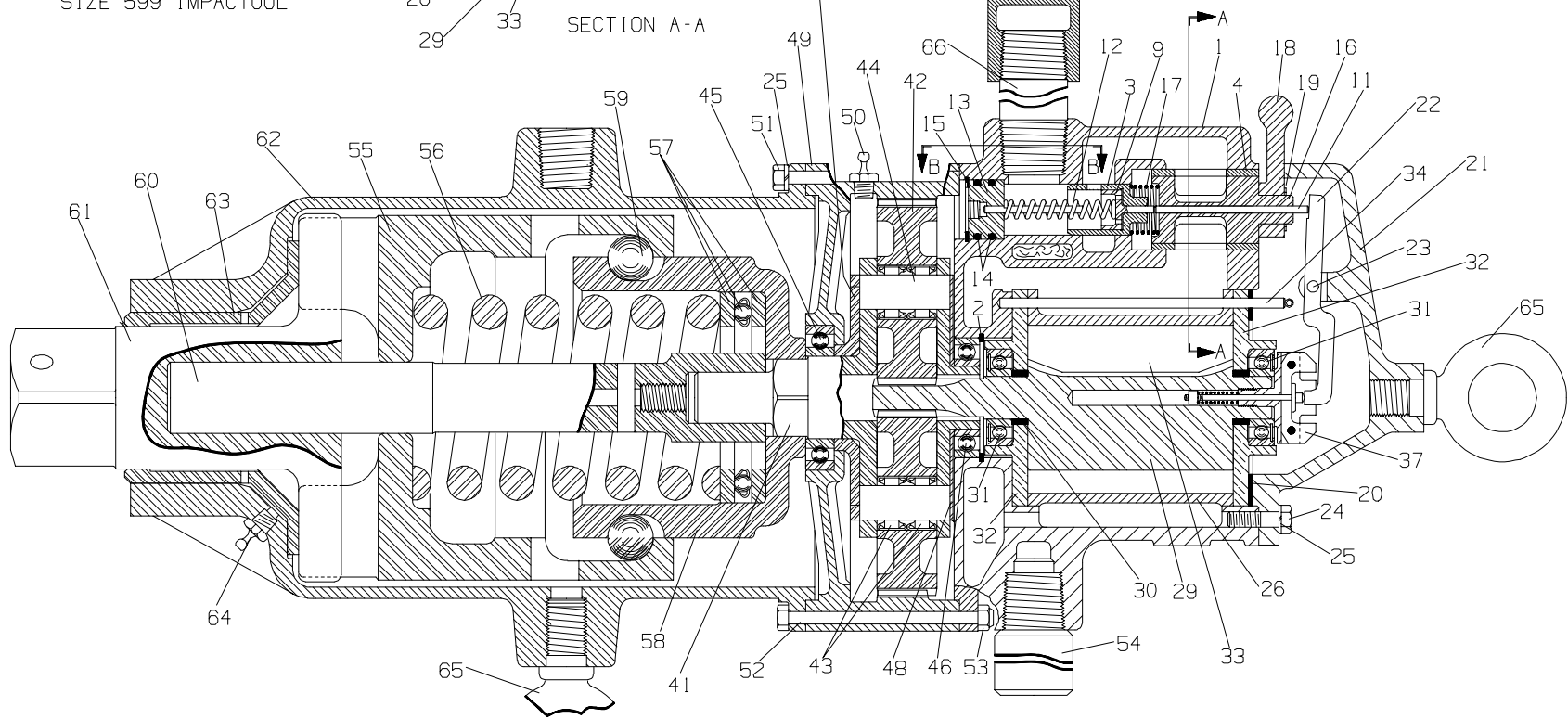
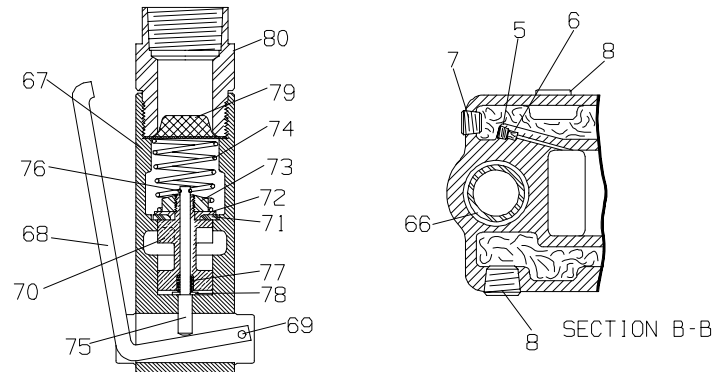
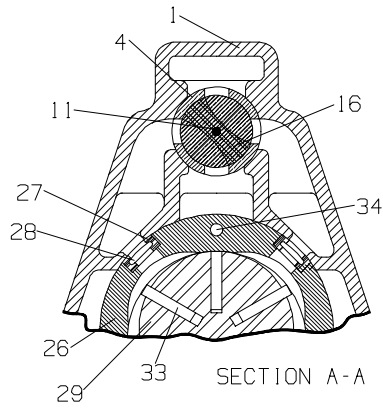

MAINTENANCE SECTION

(Dwg. TPA18-2)

PART NUMBER FOR ORDERING



PART NUMBER FOR ORDERING



1	Motor Housing	599-40	29	Rotor	599-53
2	Gear Frame Bearing Seat	599-118	30	Rotor Bearing Spacer (2)	599-65
3	Governor Valve Bushing	599-429	• 31	Rotor Bearing (2)	20BM-24
4	Reverse Valve Bushing	599-330	• 32	Cylinder End Plate (2)	599-11
5	Oiler Adjustment Screw (2)	JA4-71	• 33	Vane Packet (Set of 5)	SS800-42A-5
6	Oiler Felt (4)	JA4-75	34	Cylinder Dowel	599-98
7	Housing Plug	GA57-95	37	Weight-Type Governor Assembly	599-A424
8	Oil Chamber Plug (3)	599-276	41	Planet Gear Frame	599-8A
*	Nameplate		41A	Gear Frame Front Spacer	599-331
	for models ending in -EU	599-EU-245	42	Planet Gear (2)	599-10
	for all other models	599-245	43	Planet Gear Bearing (4)	599-654
9	Governor Valve	599-425	44	Planet Gear Shaft (2)	599-191
11	Governor Valve Plunger	599-439	45	Gear Frame Front Bearing	2115-141
12	Governor Valve Spring	599-431	46	Gear Frame Rear Bearing	599-99
13	Governor Valve Cap	599-433	48	Gear Frame Rear Spacer	599-332
14	Governor Valve Cap Seal (2)	FMD2-198	49	Gear Case	599-37
15	Governor Valve Cap Retainer	FMB2-6	50	Grease Fitting	23-188
16	Reverse Valve	599-329	51	Hammer Case Short Bolt (2)	599-637A
17	Reverse Valve Spring	6CND-232-3/4	52	Hammer Case Long Bolt (6)	599-636A
18	Reverse Lever	599-163	53	Hammer Case Bolt Nut (6)	599-639
19	Reverse Lever Retainer (2)	21-408	54	Dead Handle	599-48
20	Back Head Gasket	20BM-283	55	Hammer	599-724
21	Back Head	599-102	56	Hammer Spring	599-728
22	Governor Lever	599-436	57	Hammer Spring Thrust Bearing	599-695
23	Governor Lever Pin	AVI-64	58	Ball Cam	599-721
24	Back Head Cap Screw (7)	599-103	59	Cam Ball (1-3/8" diameter steel ball) (2)	599-722
25	7/16" Lock Washer (9)	D02-537	60	Arbor	599-725
26	Cylinder	20QDM-3	61	Anvil	599-726
27	Air Port Gasket (6)	20BM-210			
28	Gasket Retaining Spring (6)	20BM-200			

MAINTENANCE SECTION

* Not illustrated.

- To keep downtime to a minimum, it is desirable to have on hand certain repair parts. We recommend that you stock one (pair or set) of each part indicated by a bullet (•) for every four tools in service.

PART NUMBER FOR ORDERING 

PART NUMBER FOR ORDERING 

62	Hammer Case Assembly		68	Throttle Lever	599-273
	for models ending in-EU	599-EU-A727	69	Throttle Lever Pin	T22-306
	for all other models	599-A727	70	Throttle Valve	599-168
63	Hammer Case Bushing	599-641	71	Throttle Valve Face	599-159
64	Grease Fitting	23-188	72	Throttle Valve Face Cap	599-157
*	Hammer Case Label		73	Throttle Valve Face Cap Nut	D02-418A
	for models ending in-EU	EU-99	74	Throttle Valve Spring	599-262
	for all other models	WARNING-2-99	75	Throttle Valve Stem	599-161
*	Oversize Hammer Case Bushing		76	Throttle Valve Stem Seal	R2F-167
+	.005" oversize	599-641-5	77	Throttle Valve Stem Spring	B01-11
+	.010" oversize	599-641-10	78	Throttle Valve Stem Washer	S12-675
+	.015" oversize	599-641-15	79	Air Strainer Screen	599-61
+	.031" oversize	599-641-31	80	Air Strainer Body	599-565
65	Eyebolt (3)	22-104	*	Socket	#
66	Throttle Connector	599-333	*	Socket Pin	599-215
	Lever Throttle Assembly	599-A301	*	Socket Pin Retainer	599-216
67	Throttle Body	599-301	*	Grease Gun	P25-228

- * Not illustrated.
- # Inquire at nearest Ingersoll-Rand Branch Office for Sockets.
- + Refer to Oversize Hammer Case Bushings on page 9.

MAINTENANCE SECTION

⚠ WARNING

Always wear eye protection when operating or performing maintenance on this tool.

Always turn off the air supply and disconnect the air supply hose before installing, removing or adjusting any accessory on this tool or before performing any maintenance on this tool.

OILER ADJUSTMENT

A Metered amount of oil, carried from the oil chamber to the motor by live air, lubricates the Vanes (33). The amount of oil admitted to the air stream is regulated by two Oiler Adjustment Screws (5).

Adjustment is made at the factory and should not be changed unless lubricating difficulties are experienced. If adjustment becomes necessary, turn the Oiler Adjustment Screws with a small screwdriver. **Turning the Screws in reduces the oil flow; backing the Screws out increases the oil flow.**

Two Oiler Felts (6) are located under each Screw. After long usage, these Felts may become clogged, preventing the passage of oil. If this happens, remove the Plugs and Screws and replace the Felts.

GOVERNOR ADJUSTMENT

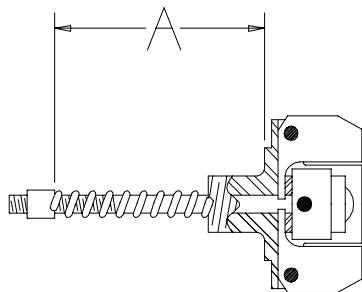

(Dwg. TPD497)

The above view illustrates the sensitive weight-type Governor which controls the speed of the Multi-Vane motor. It is adjusted at the factory to produce a socket speed of approximately 295 rpm. It is seldom necessary to change this adjustment. However, if the free speed of the square driver is checked with a tachometer and is not within 5 rpm of the recommended speed of 295 rpm, steps should be taken to correct it. Screwing the adjusting nut farther onto the governor stem increases the speed; backing the nut off decreases the speed. One-half turn of the nut will vary the socket speed about 5 rpm.

When installing a new Governor, set the Nut so that dimension "A" is 2-1/8" (54 mm). This usually produces an allowable speed.

DISASSEMBLY

General Instructions

1. Do not disassemble the tool any further than necessary to replace or repair damaged parts.
2. Whenever grasping a tool or part in a vise, always use leather-covered or copper-covered vise jaws to protect the surface of the part and help prevent distortion. This is particularly true of threaded members and housings.
3. Do not remove any part which is a press fit in or on a subassembly unless the removal of that part is necessary for repairs or replacement.
4. Do not disassemble the Impactool unless you have a complete set of new gaskets and O-rings for replacement.

Disassembly of the Impactool

⚠ WARNING

Never attempt to disassemble a Model 599A1 Impactool without a hoist, block and tackle, or other lifting device. The complete Impactool and its major assemblies are too heavy to be manually handled. Follow the recommended procedure for disassembly below.

1. Suspend the Impactool by the Eyebolt (65) in the Back Head (21) and place a large socket on solid, level footing beneath it.
2. Lower the tool, engaging the square driver in the socket drive hole. As a precaution, leave the hoist hook attached to the Eyebolt so that the Impactool cannot tip over.
3. Remove the Hammer Case Bolts (51) and (52). Slowly lift the Motor Housing (1), with assembled parts, from the Gear Case. If the Motor Housing and Gear Case fail to separate after raising the Motor Housing about 1/2" (12 mm), lightly strike the Gear Case with a soft hammer to jar it loose.
4. Attach the hoist sling to the planet gear frame assembly and lift the Gear Case (49) with assembled parts from the Hammer Case (62). If the Gear Case and Hammer Case fail to separate after raising the Gear Case about 1/2" (12 mm), lightly strike the hammer case bosses a few downward blows with a soft hammer.
5. Remove the Backhead Cap Screws (24) and Backhead (21). This will give access to the motor.

Disassembly of the Impact Mechanism

1. Support the Hammer (55), jaw end down, on a press table and press on the rear face of the Ball Cam (58), telescoping the two parts against the compression of the Hammer Spring (56) until the two Cam Balls (59) drop from the holes in the hammer wall.

MAINTENANCE SECTION

2. Release the pressure slowly after removal of the Balls and withdraw the Ball Cam from the Hammer.

Disassembly of the Motor

NOTICE

Never clamp the Cylinder (26) in a vise.

1. Lay the motor horizontally on a work bench and unscrew the governor assembly.

NOTICE

The Rotor (29) and Governor (37) have left-hand threads; turn the governor assembly clockwise to remove it from the motor assembly.

2. Insert a 7/16" (11 mm) diameter rod about 8" (203 mm) long into the rotor bore.
3. Grasp the Cylinder with one hand and sharply strike the rod until the rotor rear hub is driven from the rear Rotor Bearing (31).
4. Support the front Cylinder End Plate (32) as close to the rotor body as possible and press the pinion end of the Rotor out of the front Rotor Bearing.
5. Remove any other motor components which need to be replaced.

ASSEMBLY

General Instructions

1. Always press on the **inner** ring of a ball-type bearing when installing the bearing on a shaft.
2. Always press on the **outer** ring of a ball-type bearing when pressing the bearing into a bearing recess.
3. Whenever grasping a tool or part in a vise, always use leather-covered or copper-covered vise jaws. Take extra care with threaded parts and housings.
4. Always clean every part and wipe every part with a thin film of oil before installation.
5. Apply a film of o-ring lubricant to all O-rings before final assembly.

Assembly of the Motor

1. Using an arbor that contacts only the **outer** ring of the Bearings, press the Rotor Bearings (31), **shielded side first**, into the recesses in the Cylinder End Plates (32).

NOTICE

Press only on the bearing inner ring when installing the end plate and bearing assemblies on the rotor hubs.

Be sure to press each assembly onto the rotor hub until the bearing **inner** ring contacts the Rotor Bearing Spacer (30).

2. Be sure the rubber Air Port Gaskets (27) and Gasket Retaining Springs (28) are in good condition and that one of each is in position in each of the six air ports in the wall of the Cylinder (26) before sliding the motor assembly into the Motor Housing (1).
3. Install the Backhead (21) and secure the Backhead Cap Screws (24).

Assembly of the Impact Mechanism

1. Stand the Ball Cam (58), large open end up, on the press table.
2. Seat one hammer spring thrust bearing ring, grooved side up, in the recess in the Ball Cam.
3. Place the ball and retainer assembly on top of this ring. Place the second bearing ring, grooved side first, on top of the bearing balls.
4. Stand the Hammer Spring (56), either end first, on top ring of the Hammer Spring Thrust Bearing (57). Pass the Arbor (60), large end first, through the spring and bearing bores and centralize it in the Ball Cam.
5. Align the holes in the hammer wall with the cam groove points in the Ball Cam and slide the Hammer over the Cam, allowing the arbor pilot to pass through the hole in the front of the Hammer.
6. Place a sleeve over the arbor pilot and seat it against the end faces of the hammer jaws. Press on the sleeve, forcing the Hammer down over the Ball Cam, against the compression of the Hammer Spring, until a Cam Ball (59) can be inserted into each cam groove through the holes in the hammer wall.
7. Insert one Ball into each hole and slowly release the pressure.

Replacement of Planet Gear Bearings

1. When replacing Planet Gear Bearings (43), use a bearing Inserting Tool. Using a flat-faced arbor can damage the bearing shell.
2. Press only on the bearings **stamped face**.
3. Press one Bearing in from each end of the gear bore. Do not use one Bearing to force the other into position.

Assembly of the Impactool

▲ WARNING

Never attempt to assemble a Model 599A1 Impactool without a hoist, block and tackle or other lifting device. The complete Impactool and its major assemblies are too heavy to be manually handled. Follow the recommended procedure for assembly below.

1. Make sure that the square driver is engaged in a large Socket, and that the Socket is resting on level footing so that the Hammer Case containing the assembled impact mechanism components are standing upright to prevent the tool from tipping over during assembly.

MAINTENANCE SECTION

2. Screw a hook or eyebolt having a 3/4"-10 thread shank into the tapped hole in the Arbor (60). Using the hoist, lower the Hammer (55), with assembled parts, into the Hammer Case.
3. Attach the hoist sling to the planet gear frame assembly and lower the Gear Case with assembled parts onto the Hammer Case (62).
4. Attach the hoist sling to the Motor Housing and lower the Motor Housing with assembled parts onto the the Gear Case.
5. Install the Hammer Case Bolts (51) and (52) to secure the Gear Case and Motor Housing in position.

NOTICE

Periodically examine the Hammer Case Bushing (63). Install a new Bushing if the present one is worn to the extent that the shank on the Anvil (61) is a loose fit in the bushing bore. See the following instructions.

Oversize Hammer Case Bushings

The continued use of a worn Hammer Case Bushing may permit the Bushing to deform or enlarge the hole in the front of the Hammer Case so that the Case no longer retains the Bushing properly. Should the Bushing become loose in the Case, an oversize Bushing should be installed. Bushings .005", .010", .015" and .031" are available. The amount of oversize is etched on the oversize Bushing; the standard size Bushing is unmarked. After removing a loose Bushing, examine it for oversize etching. If unmarked, replace it with a .005" oversize Bushing; if it is marked, replace it with the next larger oversize Bushing. When pressed in, the oversize Bushing will automatically true up the deformed opening in the Hammer Case.

Reverse Valve Bushing

When installing a new Reverse Valve Bushing (4), align the scribe marks on the Bushing and Motor Housing (1).

MAINTENANCE SECTION

TROUBLESHOOTING GUIDE		
Trouble	Probable Cause	Solution
Low power	Worn or broken Vanes	Replace complete set of Vanes.
	Worn or broken Cylinder and/or scored End Plates	Examine the Cylinder and replace it if it is worn or broken or if the bore is scored or wavy. Replace End Plates if they are scored.
	Dirty motor parts	Disassemble the tool and clean all parts with a clean, suitable, cleaning solution, in a well ventilated area. Assemble the Tool and inject 3 cc of recommended oil into Inlet and run Tool to lubricate internal parts.
	Improper positioning of the Reverse Valve	Make certain Reverse Valve is fully engaged.
Motor will not run	Incorrect assembly of the motor	Disassemble motor, replace worn or broken parts and reassemble as instructed.
	Insufficient lubricant in the impact mechanism	Remove the Hammer Case Assembly and lubricate impact mechanism.
Tool will not impact	Broken or worn impact mechanism parts	Remove the Hammer Case and examine the impact mechanism parts. Replace any worn or broken parts.
	Impact mechanism not assembled correctly	Refer to Assembly of the Impact Mechanism .

NOTICE

SAVE THESE INSTRUCTIONS. DO NOT DESTROY.

NOTES