

MODEL 8056 IMPACTOOL

⚠ WARNING

When using electric tools, basic safety precautions should always be followed to reduce the risk of fire, electric shock and personal injury, including the following:

READ ALL INSTRUCTIONS.

Use only Impact Wrench Sockets and Accessories on this Impactool. Do not use hand sockets and accessories.

SAFETY INSTRUCTIONS FOR USE OF ALL PORTABLE ELECTRIC TOOLS.

GROUNDING INSTRUCTIONS

These tools must be grounded while in use to protect the operator from electric shock. These tools are equipped with an approved three-conductor cord and three prong grounding-type plug to fit the proper grounding-type receptacle. The green (or green and yellow) conductor in the cord is the grounding wire. Never connect the green (or green and yellow) wire to a live terminal. If a unit is for use on less than 150 volts, it has a plug that looks like Figure A.

An adapter, Figure B is available for connecting figure A plugs to 2-prong receptacles. The green colored rigid grounding strap extending from the adapter must be connected to a permanent ground such as to a properly grounded outlet box, like Figure C.

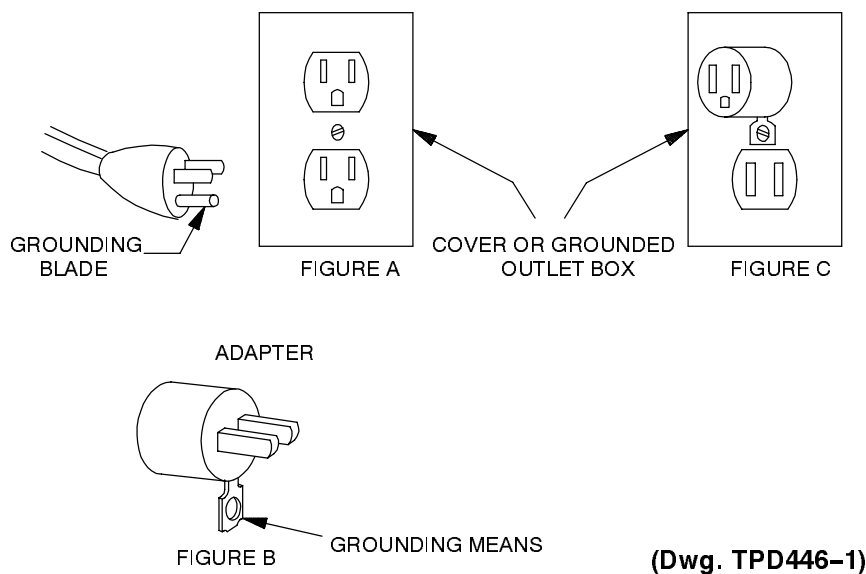

NOTICE

For safe use of adapters, the outlet box must be grounded. If there is any doubt, have a qualified electrician check connections.

The use of other than genuine Ingersoll-Rand replacement parts may result in decreased tool performance and increased maintenance and may invalidate all warranties.

Refer All Communications to the Nearest
Ingersoll-Rand Office or Distributor.

© Ingersoll-Rand Company 1998

Printed in U.S.A.

INGERSOLL-RAND®
PROFESSIONAL TOOLS

For grounded tools use only three wire extension cords which have three prong grounding type plugs and three pole receptacles which accept the tool's plug. Replace or repair damaged cords.

If an extension cord is to be used outdoors, only cords with the suffix W-A following the cord type designation shall be used (example SJTW-A) to indicate it is acceptable for outdoor use.

Inspect extension cords for loose or exposed wires and damaged insulation. Make needed repairs or replacement before use.

FOR ALL TOOLS:

- **Keep work area clean.**
Cluttered areas and benches invite injuries.
- **Consider work area environment.**
Don't expose power tools to water.
Don't use power tools in damp or wet conditions.
Keep work area well lit.
Do not use tool in presence of flammable liquids or gases.
- **Guard against electric shock.**
Prevent body contact with grounded surfaces, such as pipes, radiators, ranges and refrigerator enclosures.
- **Keep children away.**
Do not permit visitors to contact tool or extension cord.
All visitors should be kept away from work area.
- **Store idle tools.**
When not in use, tool should be stored in dry, and high or locked up place out of reach of children.
- **Don't force tool.**
It will do the job better and safer at the rate for which it is intended.
- **Use the right tool.**
Don't force a small tool or attachment to do the job of a heavy duty tool.
Don't use tool for purpose not intended for example don't use circular saw for cutting tree limbs or logs.
- **Dress properly.**
Do not wear loose clothing or jewelry. They can be caught in moving parts.
Rubber gloves and non skid footwear are recommended when working outdoors.
Wear protective hair covering to contain long hair.
- **Use safety glasses.**
Also use face or dust mask if cutting operation is dusty.
- **Don't abuse cord.**
Never carry tool by cord or yank it to disconnect from receptacle.
Keep cord from heat, oil and sharp edges.
- **Secure work.**
Use clamps or a vise to hold work.
It's safer than using your hand and it frees both hands to operate tool.
- **Don't overreach.**
Keep proper footing and balance at all times.
- **Maintain tools with care.**
Keep tools sharp and clean for better and safer performance.
Follow instructions for lubricating and changing accessories.
Inspect tool cords periodically and if damaged, have repaired by authorized service facility. Inspect extension cords periodically and replace if damaged. Keep handles dry, clean, and free from oil and grease.
- **Disconnect tools.**
When not in use, before servicing, and when changing accessories, such as blades, bits, cutters, etc.
- **Remove adjusting keys and wrenches.**
Form habit of checking to see that keys and adjusting wrenches are removed from tool before turning it on.

- **Avoid unintentional starting.**

Don't carry plugged in tool with finger on switch.

Be sure switch is off when plugging in.

- **Extension cords.**

Make sure your extension cord is in good condition. When using an extension cord, be sure to use one heavy enough to carry the current your product will draw. An undersized cord will cause a drop in line voltage resulting in loss of power and overheating. The following table shows the correct size to use depending on cord length and nameplate ampere rating. If in doubt, use the next heavier gage. The smaller the gage number, the heavier the cord.

		MINIMUM GAGE FOR CORD SETS			
		Total Length of Cord in Feet			
Volts 120V		0-25	26-50	51-100	101-150
Ampere Rating		AWG			
More Than	Not More Than				
0	6	18	16	16	14
6	10	18	16	14	12
10	12	16	16	14	12
12	16	14	12	Not Recommended	

- **Outdoor use extension cords.**

When tool is used outdoors, use only extension cords intended for use outdoors and so marked.

- **Stay alert.**

Watch what you are doing.

Use common sense.

Do not operate tool when you are tired.

- **Check damaged parts.**

Before further use of the tool, a guard or other part that is damaged should be carefully checked to determine that it will operate properly and perform its intended function. Check for alignment of moving parts, binding of moving parts, breakage of parts, mounting, and any other conditions that may affect its operation.

A guard or other part that is damaged should be properly repaired or replaced by an authorized service center unless otherwise indicated elsewhere in this instruction manual.

Have defective switches replaced by authorized service center. Do not use tool if switch does not turn it on or off.

SAVE THESE INSTRUCTIONS. DO NOT DESTROY.

MOTOR

The Model 8056 Impactool is driven by a "universal" type 115 volt motor. It will operate on either Direct Current or Alternating Current of 25, 40, 50 or 60 cycles.



Use the Impactool only on the voltage range indicated on the nameplate, located on the top of the Motor Housing.

LUBRICATION

1. After each eight hours of operation, inject about 3 cc of Ingersoll Rand No. 100 Grease through the Grease Fitting (2) in the Housing (10 to 15 strokes from the No. R000A2 228 Grease Gun). This Grease, specially compounded for lubrication of the impact unit, has no recommended substitute.
2. After each forty hours of operation, inject about 1.5 cc of Ingersoll Rand No. 28 Grease through the Grease Fitting (15) in the back face of the Gear Case (5 to 7 strokes from the No. R000A2 228 Grease Gun).
3. Occasionally the Gear Case (13) should be removed and the impact unit withdrawn from the Housing (1) for lubrication inspection. The impact unit consists of two parts the Hammer assembly and the Anvil (72), both of which will slide freely from the Housing (1) after the Gear Case (13) is removed. Check and, if necessary, coat with Ingersoll Rand No. 100 Impactool Grease the jaws of both Hammer (76) and Anvil (72), the pilot of the Hammer unit that enters the Anvil (72) and the shank of the Anvil that takes its bearing in the Housing (1). Apply grease evenly and sparingly. An excessive accumulation of grease in the impact unit chamber in the Housing (1) will result in sluggish operation. Insert about 1.5 cc of Ingersoll Rand No. 100 Grease into each of the two holes in the wall of the Hammer (76), working it back into the cam grooves.

OPERATION

After grounding the Tool and inserting the Cable Plug in the outlet, the Model 8056 is ready for use. The motor is started by depressing the Trigger (57); releasing the Trigger stops the motor.

To change the direction of rotation, move the Reverse Lever (71), the ends of which protrude through the elongated slots in the Reverse Mechanism Cover (4). Forward and Reverse positions of the Lever are plainly marked on the Cover.

Always release Trigger and allow motor to stop before moving Reverse Lever.

Always shift Reverse Lever as far as stops permit.

When removing nuts do not allow impacting to continue for more than fifteen seconds unless the nut begins to turn. If the nut fails to start within this length of time, stop the motor, reverse the direction of rotation and allow the Tool to impact on the nut for a few seconds in the "Forward" direction. When the Tool is again operated in the "Reverse" direction, the frozen nut usually breaks loose and turns. Impacting for more than fifteen seconds at a time on a frozen nut that refuses to break loose, places a severe strain on the Impactool.

GRIP HANDLE

The Grip Handle (7) is normally located directly opposite the Switch Handle (51) as shown in the right hand view of the sectional illustration. It may, however, be turned 90° either side of the vertical center line to allow the Impactool to be used on certain applications where the present position of the Grip Handle would cause interference. One top and one centrally located Gear Case Cap Screw (16) are then used instead of the two top Cap Screws to attach the Grip Handle Bracket (12) to the Impactool. Loosen the Grip Handle Pinch Bolt (8) at the front of the Handle to permit its being rotated on the front of the Housing.

BRUSHES AND COMMUTATOR

Failure of the motor to start to operate efficiently can usually be attributed to worn or damaged Brushes. Brushes sticking in the holders and failing to make proper contact with the commutator becoming dirty or rough. Frequent inspection of Brushes and commutator is recommended.

WARNING

Disconnect the power supply cord from the receptacle before checking or replacing the brushes.

Remove the Reverse Mechanism Cover (4) containing the Reverse Lever (7). See that the Brushes are free of dust and dirt, that they slide freely in their holders and that the Brush Springs (68) hold them firmly against the commutator. If the Brushes are short, broken or chipped, they should be replaced. To remove a Brush unscrew the Brush Retainer Screw (67), freeing the Brush Retainer (66) and allowing the Spring and Brush to be withdrawn from the holder. Join the new Brush to the Spring by inserting the round end of the Brush into the first coil of the Spring and reassemble. If the commutator is dirty or rough, it can be cleaned and smoothed by holding very fine sandpaper against it with a non conductive implement while it is rotating, or any good, commercial commutator cleaner or Brush Seater may be used.

Do not use emery cloth.

NOTICE

Any further servicing or maintenance of the Model 8056 Impactool should be performed by an authorized Ingersoll-Rand Representative. Contact your nearest Ingersoll-Rand Service and Parts Distributor.

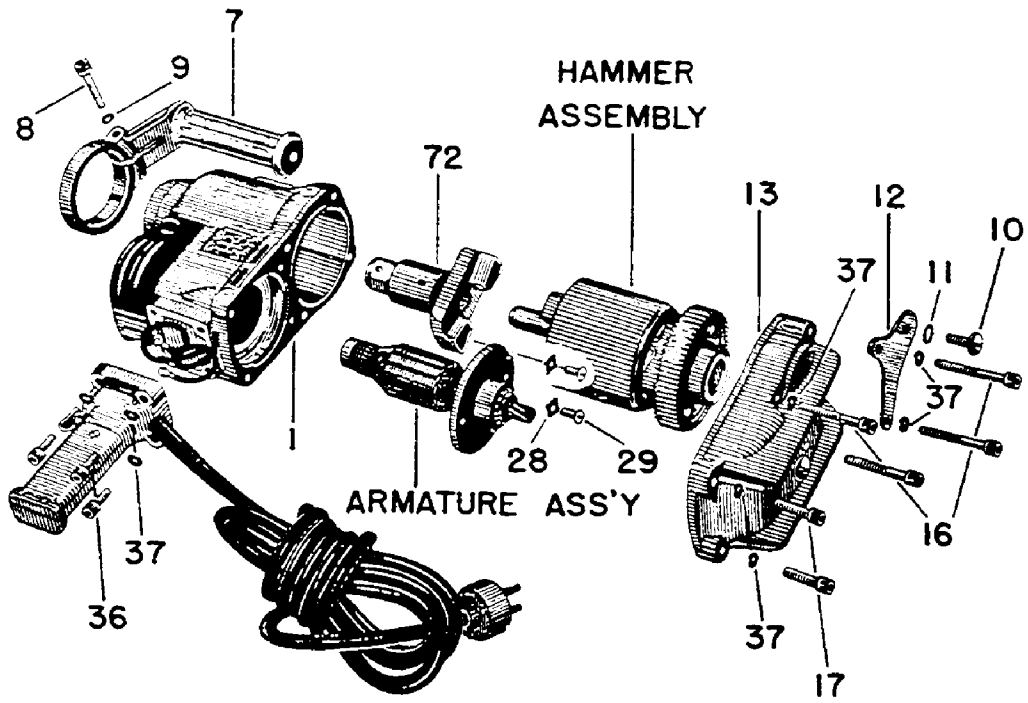

Impacttool Disassembled Into Subassemblies

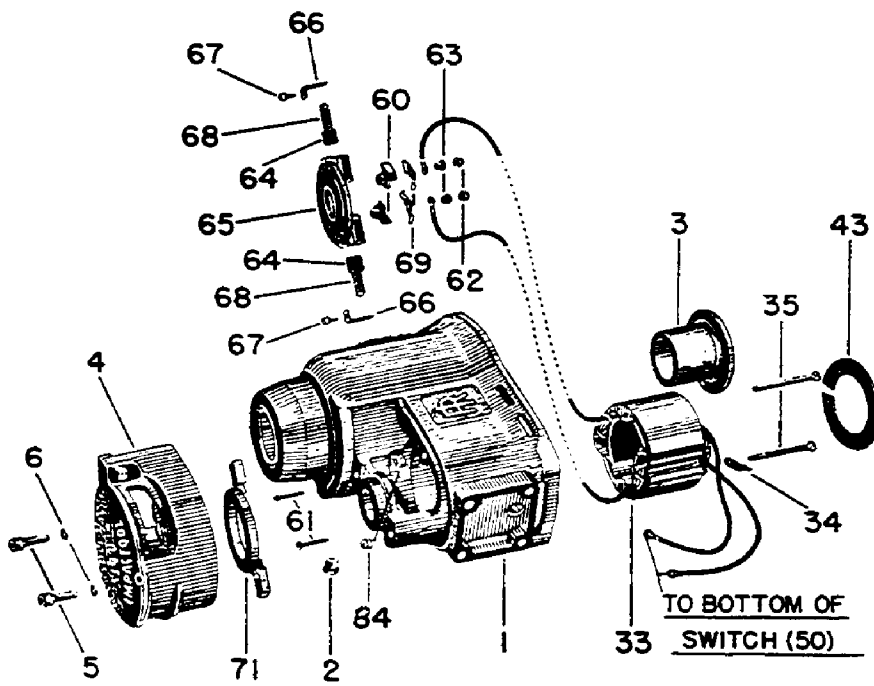

Housing Unit Disassembled

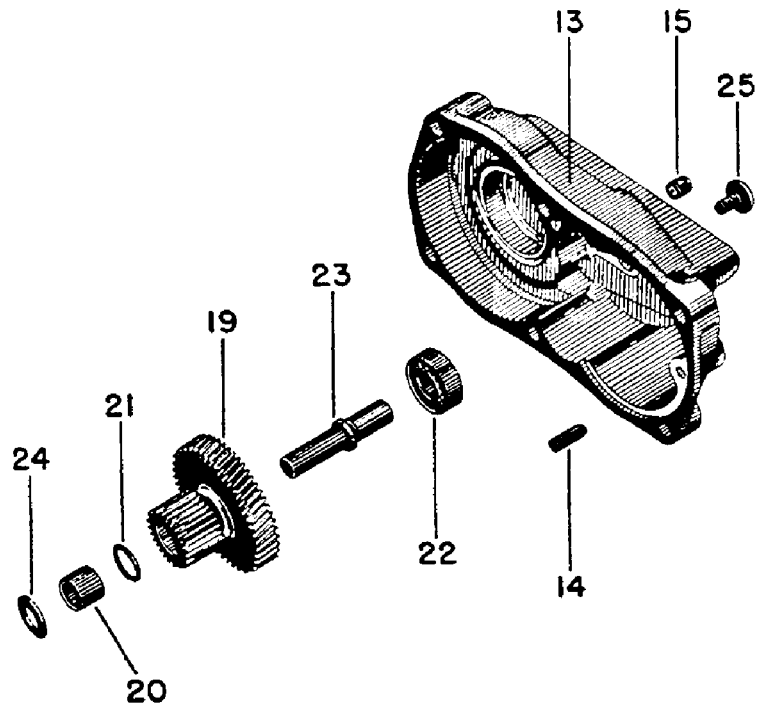

Gear Case Disassembled

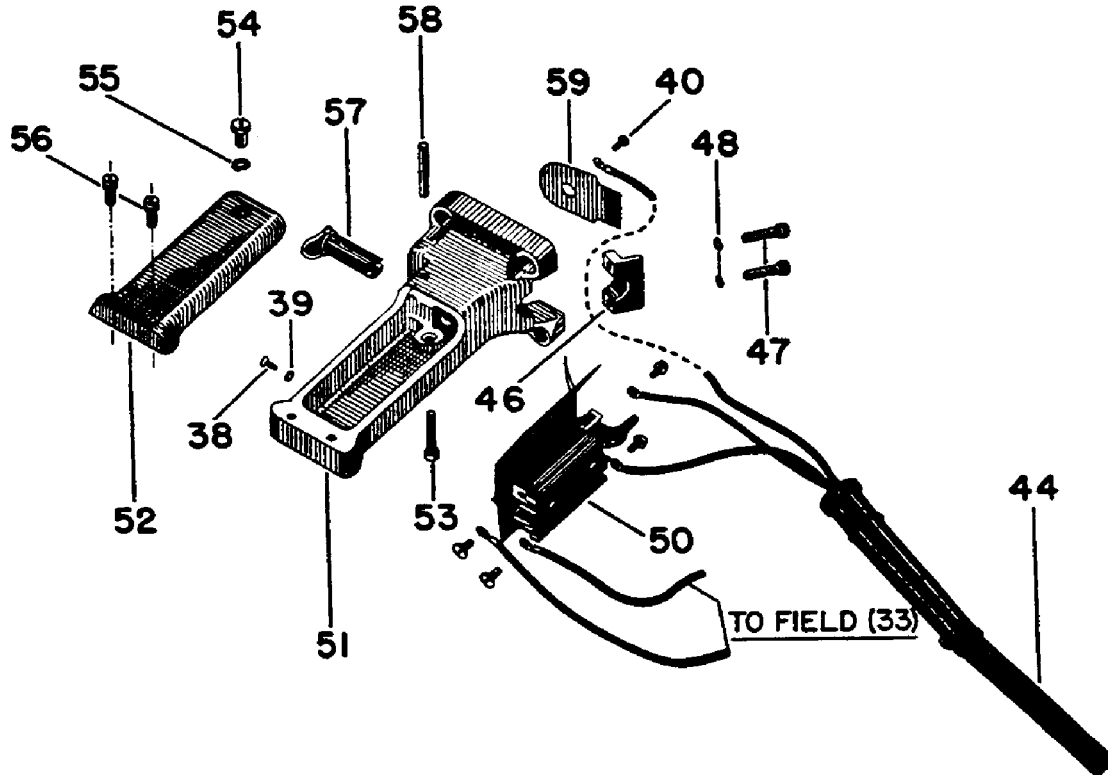

Switch Handle Disassembled

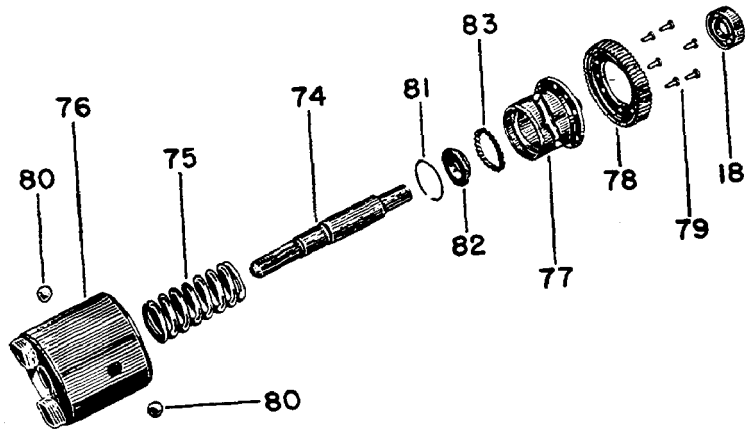

Hammer Unit Disassembled

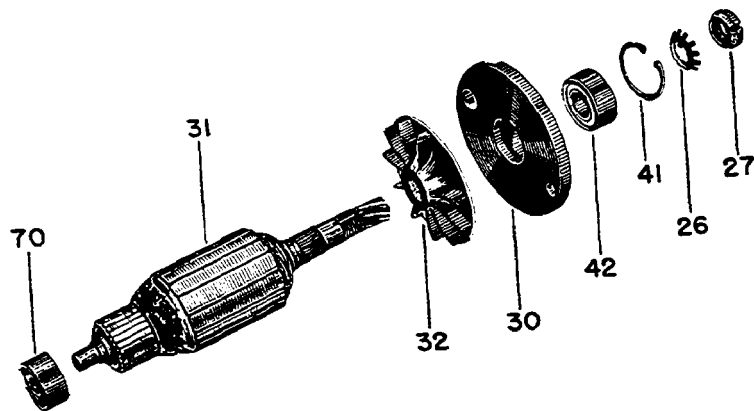

Armature Disassembled

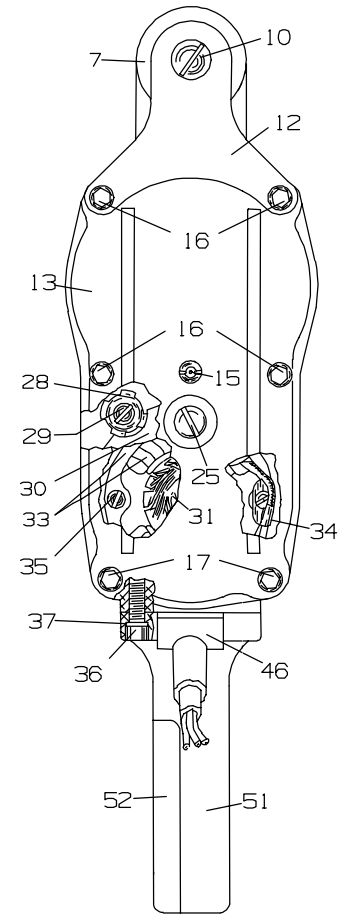
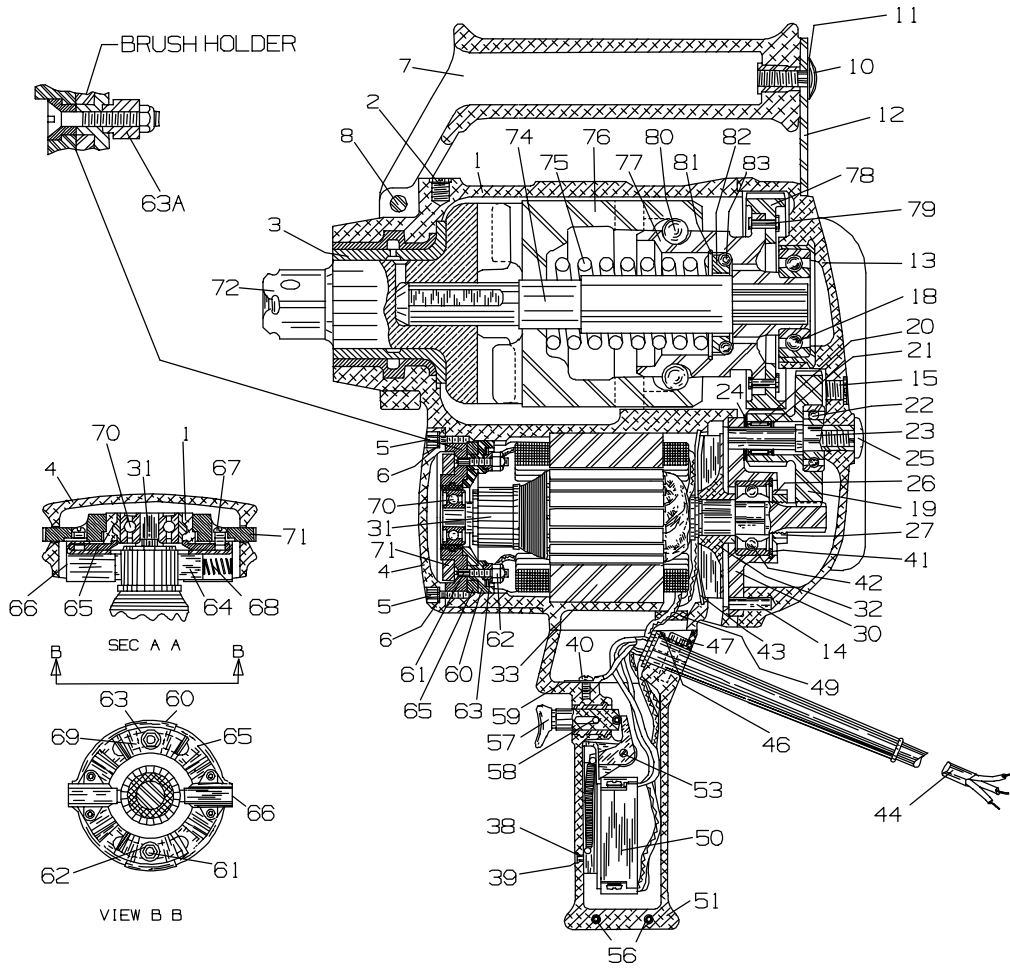
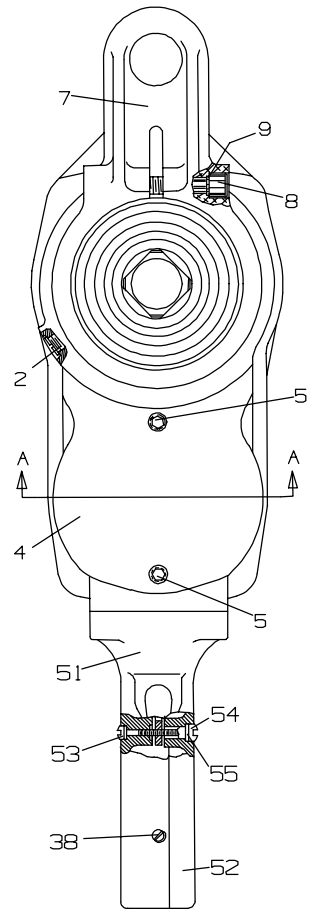

PART NUMBER FOR ORDERING 

PART NUMBER FOR ORDERING 

6

1	Motor Housing	34U-40A	22	Intermediate Gear Rear Bearing	R1L-24
2	Grease Fitting	34U-188	23	Intermediate Gear Bearing Stud	34U-502
3	Hammer Case Bushing (standard)	34U-641A	24	Intermediate Gear Thrust Washer	34U-528
*	Hammer Case Label	WARNING-15-99	25	Stud Lock Screw	518-119
3	Oversize Hammer Case Bushing		26	Armature Bearing Nut Retaining Washer	34U-66
	.005" oversize	34U-641A-5	27	Armature Bearing Nut	34U-56
	.010" oversize	34U-641A-10	28	Motor Cover Retainer (2)	34U-208
	.015" oversize	34U-641A-15	29	Motor Cover Retaining Screw (2)	34U-634
4	Reverse Mechanism Cover	34U-441A	30	Motor Cover	34U-720
5	Reverse Mechanism Cover Screw (2)	34U-667A	31	Armature	65UW-53
6	Reverse Mechanism Cover Screw Lock		32	Armature Fan	34U-62S
	Washer (2)	8U-58	33	Field	65UW-54
7	Grip Handle	34U-81	34	Field Lead Clamp	34U-375
8	Grip Handle Pinch Bolt	34U-104	35	Field Bolt (2)	34U-354
9	5/16" Lock Washer	34U-58	36	Switch Handle Screw (4)	34U-150
10	Grip Handle Bracket Screw	518-119	37	5/16" Lock Washer (10)	34U-58
11	Grip Handle Bracket Screw Lock Washer	34U-67	38	Switch Mounting Screw	4U-262
12	Grip Handle Bracket	34U-734	39	Switch Mounting Screw Lock Washer	4U-263
13	Gear Case	34U-37	40	Ground Wire Screw (includes lock washer)	17888
14	Gear Case Dowel	14SR-45	41	Rear Armature Bearing Retainer	34U-486
15	Grease Fitting	34U-188	42	Rear Armature Bearing	34U-22
16	Gear Case Long Cap Screw (4)	34U-104	43	Fan Shroud	34U-162
17	Gear Case Short Cap Screw (2)	34U-103	44	Cable (15 ft. of No. 16, three-conductor	
18	Ball Cam Bearing	G7-24		cable with plug and cable protector	
19	Intermediate Gear (58 teeth/21 teeth)	34U-82		molded on)	34U-239A
20	Intermediate Gear Front Bearing	34U-367	46	Cable Protector Clamp	34U-236
21	Intermediate Gear Bearing Retainer	34U-118	47	Cable Protector Clamp Screw (2)	34U-463

* Not illustrated.

PART NUMBER FOR ORDERING

PART NUMBER FOR ORDERING

49	Housing Grommet	34U-527	68	Brush Spring (2)	34U-28
50	Switch (includes binder screws and lock washers)	34U-255	69	Stationar Contact (4)	34U-20
51	Switch Handle	34U-160	70	Front Armature Bearing	4U-24
52	Handle Plate	34U-224	71	Reverse Lever	34U-666
53	Switch Pivot Screw (includes lock washer)	34U-359	72	Anvil	34U-726A
54	Switch Pivot Screw Nut	4E-261	74	Arbor	34U-728
55	Pivot Screw Nut Lock Washer	8U-58	75	Hammer Spring	34U-728
56	Handle Plate Screw (includes lock washer) (2)	4U-226	76	Hammer	34U-724
57	Trigger	34U-93		Ball Cam Assembly	34U-A721
58	Trigger Stop Pin	20QDM-330	77	Ball Cam	34U-721
59	Switch Wire Guide	34U-55	78	Ball Cam Gear	34U-9
60	Plate Spacer (2)	34U-15	79	Ball Cam Gear Rivet (6)	34U-542
61	Spacer Screw (2)	34U-16	80	Cam Ball (2) (1/2" diameter steel ball)	D10-280
62	Field Lead Nut (2) (Elastic Stop Nut)	4U-139	81	Race Retainer	34U-729
63	Screw Insulating Bushing (2)	4U-18C	82	Hammer Spring Thrust Bearing Race	34U-695
63A	Insulating Bushing (2)	4U-18B	83	Hammer Spring Thrust Bearing Ball (21 required) (1/4" diameter steel ball)	4U-722
64	Brush (2)	34U-12	84	Field Bolt Nut (2)	504-639
65	Brush Holder Plate	34U-14	*	Socket Retainer	RR10015S
66	Brush Retainer (2)	34U-25	⊗ *	Cable Plug (for non-molded cable)	5U-438
67	Brush Retainer Screw (includes lock washer) (2)	34U-26	⊗ *	Cable Protector (for non-molded cable)	4E-235

* Not illustrated.

⊗ Repair parts only. No longer furnished as standard equipment.

NOTES