

## INSTRUCTIONS FOR MODEL AW7500 ULTRA DUTY AUTOMOTIVE IMPACT WRENCH

### NOTICE

Model AW7500 Ultra Duty Impact Wrench is designed for general maintenance of on/off road trucks, busses and farm equipment.

Mac Tools is not responsible for customer modification of tools for applications on which Mac Tools was not consulted.

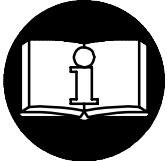

### ⚠ WARNING

**IMPORTANT SAFETY INFORMATION ENCLOSED.  
READ THIS MANUAL BEFORE OPERATING TOOL.**

**IT IS THE RESPONSIBILITY OF THE EMPLOYER TO PLACE THE INFORMATION  
IN THIS MANUAL INTO THE HANDS OF THE OPERATOR.**

**FAILURE TO OBSERVE THE FOLLOWING WARNINGS COULD RESULT IN INJURY.**

#### PLACING TOOL IN SERVICE

- Always operate, inspect and maintain this tool in accordance with all regulations (local, state, federal and country), that may apply to hand held/hand operated pneumatic tools.
- For safety, top performance, and maximum durability of parts, operate this tool at 90 psig (6.2 bar/620 kPa) maximum air pressure at the inlet with 1/2" (13 mm) inside diameter air supply hose.
- Always turn off the air supply and disconnect the air supply hose before installing, removing or adjusting any accessory on this tool, or before performing any maintenance on this tool.
- Do not use damaged, frayed or deteriorated air hoses and fittings.
- Be sure all hoses and fittings are the correct size and are tightly secured. See Dwg. TPD905-1 for a typical piping arrangement.
- Always use clean, dry air at 90 psig maximum air pressure. Dust, corrosive fumes and/or excessive moisture can ruin the motor of an air tool.
- Do not lubricate tools with flammable or volatile liquids such as kerosene, diesel or jet fuel.
- Do not remove any labels. Replace any damaged label.
- The use of a hose whip is recommended. A coupler connected directly to the air inlet increases tool bulk and decreases tool maneuverability.
- For maximum performance, the coupler on the wall should be the next size larger than the coupler used on the tool. The coupler closest to the tool should not be less than the proper air supply hose size.

#### USING THE TOOL

- Always wear eye protection when operating or performing maintenance on this tool.
- Always wear hearing protection when operating this tool.
- Keep hands, loose clothing and long hair away from rotating end of tool.
- Note the position of the reversing buttons or mechanism before operating the tool to be aware of the direction of rotation when operating the throttle.
- Anticipate and be alert for sudden changes in motion during start up and operation of any power tool.
- Keep body stance balanced and firm. Do not overreach when operating this tool. High reaction torques can occur at or below the recommended air pressure.
- Tool shaft may continue to rotate briefly after throttle is released.
- Air powered tools can vibrate in use. Vibration, repetitive motions or uncomfortable positions may be harmful to your hands and arms. Stop using any tool if discomfort, tingling feeling or pain occurs. Seek medical advice before resuming use.
- Use accessories recommended by Mac Tools.
- Use only impact sockets and accessories. Do not use hand (chrome) sockets or accessories.
- Impact wrenches are not torque wrenches. Connections requiring specific torque must be checked with a torque meter after fitting with an impact wrench.
- This tool is not designed for working in explosive atmospheres.
- This tool is not insulated against electric shock.

### NOTICE

The use of other than genuine Mac Tools replacement parts may result in safety hazards, decreased tool performance, and increased maintenance, and may invalidate all warranties.

Repairs should be made only by authorized trained personnel. Consult your nearest Mac Tools Authorized Servicer.

## WARNING LABEL IDENTIFICATION

### ⚠ WARNING

**FAILURE TO OBSERVE THE FOLLOWING WARNINGS COULD RESULT IN INJURY.**

	<p><b>⚠ WARNING</b></p> <p>Always wear eye protection when operating or performing maintenance on this tool.</p>
---	--

	<p><b>⚠ WARNING</b></p> <p>Always wear hearing protection when operating this tool.</p>
---	---

	<p><b>⚠ WARNING</b></p> <p>Always turn off the air supply and disconnect the air supply hose before installing, removing or adjusting any accessory on this tool, or before performing any maintenance on this tool.</p>
---	--

	<p><b>⚠ WARNING</b></p> <p>Air powered tools can vibrate in use. Vibration, repetitive motions or uncomfortable positions may be harmful to your hands and arms. Stop using any tool if discomfort, tingling feeling or pain occurs. Seek medical advice before resuming use.</p>
---	---

	<p><b>⚠ WARNING</b></p> <p>Do not carry the tool by the hose.</p>
---	---

	<p><b>⚠ WARNING</b></p> <p>Do not use damaged, frayed or deteriorated air hoses and fittings.</p>
---	---

	<p><b>⚠ WARNING</b></p> <p>Keep body stance balanced and firm. Do not overreach when operating this tool.</p>
---	---

	<p><b>⚠ WARNING</b></p> <p>Operate at 90 psig (6.2 bar/620 kPa) Maximum air pressure.</p>
---	---

## USING THE POWER MANAGEMENT SYSTEM

### ⚠ WARNING

Air wrenches are not torque control devices. Fasteners with specific torque requirements must be checked with suitable torque measuring devices after installation with an air wrench.

Model AW7500 Impact Wrench incorporates a Power Management System that allows the operator to select four power output settings. These settings range from minimum power output through maximum power output in the forward direction only.

**The Air Wrench will always operate at maximum power output in the reverse direction, no matter what power output level is selected.**

### MODEL AW7500 POWER MANAGEMENT SYSTEM

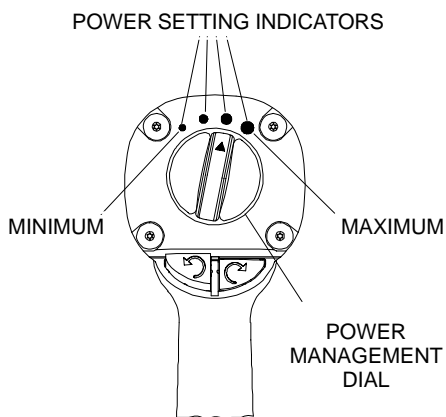

(Dwg. TPD2035)

### ⚠ WARNING

The four power setting indicators of increasing size on the rear of the housing indicate increasing power output levels, are for reference only and **DO NOT** denote a specific power output. The smallest power setting indicator designates minimum power output, the two middle power setting indicators denote medium power outputs and the largest power setting indicator denotes maximum power output.

The power output can be further reduced in forward or reverse by using the variable throttle. Air supply systems which do not deliver adequate air pressure can affect power output at all settings.

# PLACING TOOL IN SERVICE

## LUBRICATION



### Mac Tools Pneumatic Oil



**Mac Tools Pneumatic Grease** for routine external lubrication of the impact mechanism through the Hammer Case Grease Fitting.

**Mac Tools Pneumatic Grease** when disassembling and assembling the impact mechanism.

Always use an air line lubricator with these tools.  
We recommend the following Filter-Lubricator-Regulator Unit:

For USA – No. C18-03-FKG0-28  
For International – C18-C3-FKG0

## CAUTION

Do not mark any nonmetallic surface on this tool with customer identification codes. Such actions could affect tool performance.

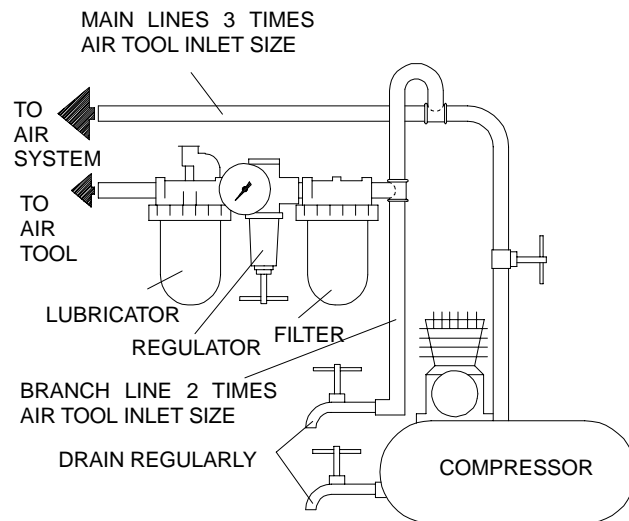

(Dwg. TPD905-1)

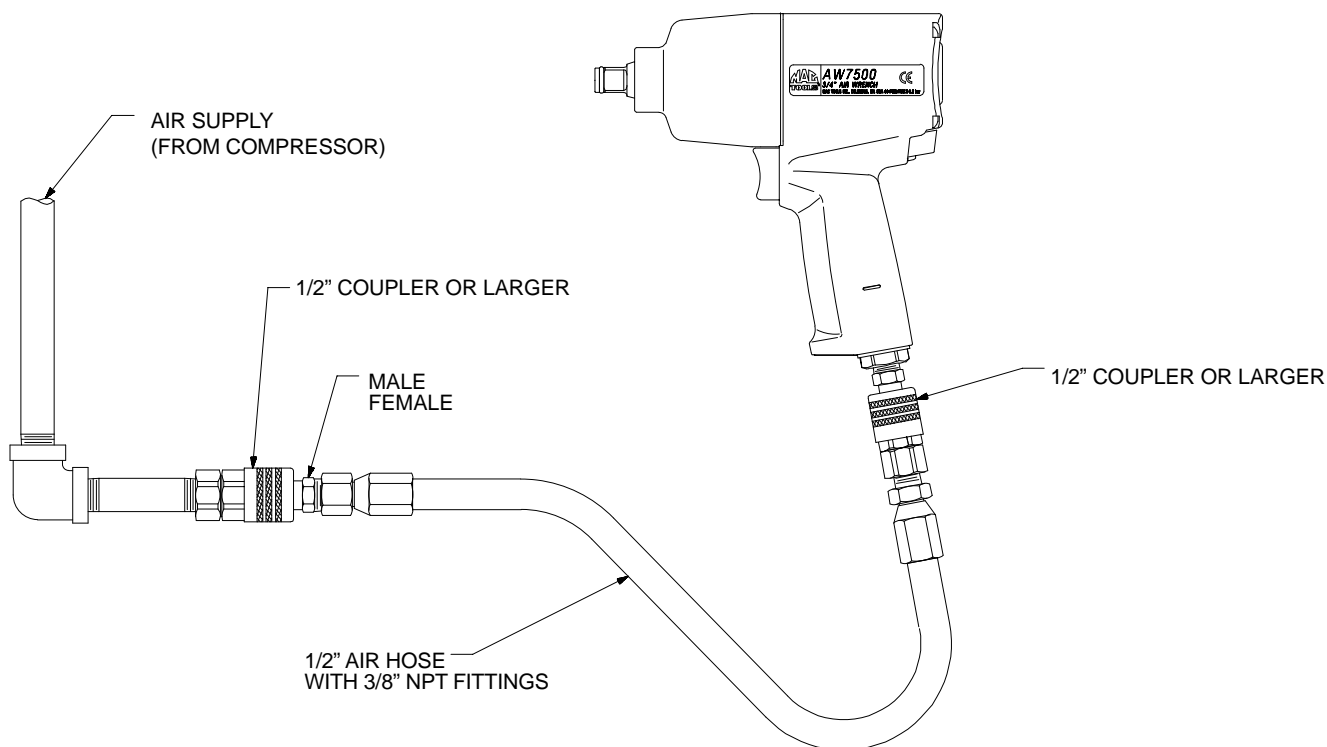

(Dwg. TPA1814)

# PLACING TOOL IN SERVICE

## SPECIFICATIONS

Model	Type of Handle	Drive	Impacts per min.	Recommended Torque Range	
				Forward Min/Max ft-lb (Nm)	Reverse Min/Max ft-lb (Nm)
AW7500	pistol grip	3/4"	1175	200-900 [1100 Max] (271-1220 [1492 Max] )	200-900 [1200 Max] (271-1220 [1627 Max] )

Model	■ Sound Level dB (A)		◆ Vibrations Level
	Pressure	Power	m/s <sup>2</sup>
AW7500	102.9	115.9	5.9

- Tested in accordance with PNEUROP PN8NTC1.2
- ◆ Tested to ISO8662-7 loaded with frictionbrake to 9 RPM

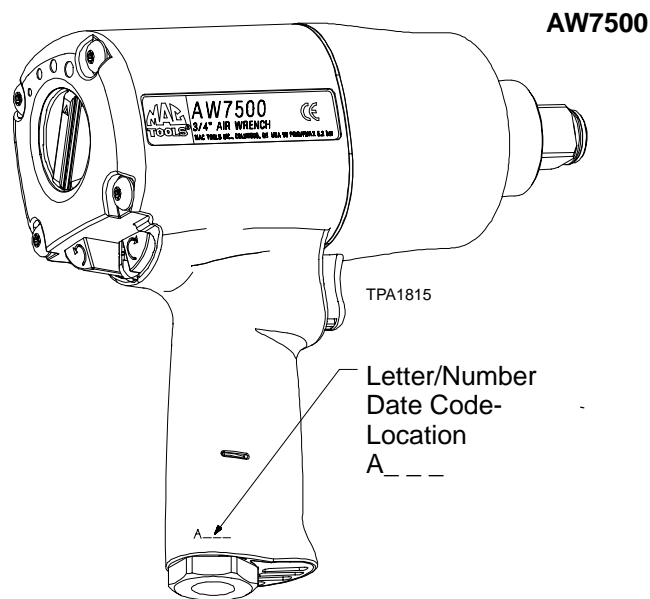

**DECLARATION OF CONFORMITY**

We Mac Tools  
(supplier's name)

Columbus, OHIO 43232 USA  
(address)

declare under our sole responsibility that the product,

Model AW7500 Ultra Duty Impact Wrench

to which this declaration relates, is in compliance with the provisions of  
98/37/EC Directives.

By using the following Principle Standards: ISO8662, PNEUROP PN8NTC1

Serial No. Range (2000 → ) A00H XXXXX →

Bill Mark  
Bill Mark  
Name and signature of authorised persons

September, 2000  
Date

**NOTICE**

**SAVE THESE INSTRUCTIONS. DO NOT DESTROY.**

**When the life of the tool has expired, it is recommended that the tool be disassembled, degreased and parts be separated by material so that they can be recycled.**

## MODE D'EMPLOI DES CLÉS À CHOCS AUTOMOBILES SÉRIE ULTRA FORTE MODÈLE AW7500

### NOTE

La clé à chocs ultra fortes modèle AW7500 est destinées à l'entretien général des camions routiers et tout terrain, des autobus et des matériels agricoles.

Mac Tools ne peut être tenu responsable de la modification des outils par le client pour les adapter à des applications qui n'ont pas été approuvées par Mac Tools.

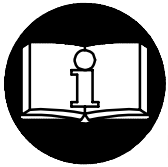

### ATTENTION

**D'IMPORTANTES INFORMATIONS DE SÉCURITÉ SONT JOINTES.**

**LIRE CE MANUEL AVANT D'UTILISER L'OUTIL.**

**L'EMPLOYEUR EST TENU DE COMMUNIQUER LES INFORMATIONS  
DE CE MANUEL AUX EMPLOYÉS UTILISANT CET OUTIL.**

**LE NON RESPECT DES AVERTISSEMENTS SUIVANTS PEUT CAUSER DES BLESSURES.**

#### MISE EN SERVICE DE L'OUTIL

- Cet outil doit toujours être exploité, inspecté et entretenu conformément à toutes les réglementations (locales, départementales, fédérales et nationales), applicables aux outils pneumatiques tenus/commandés à la main.
- Pour la sécurité, les performances optimales et la durabilité maximale des pièces, cet outil doit être connecté à une alimentation d'air comprimé de 6,2 bar (620 kPa) maximum à l'entrée, avec un flexible de 13 mm de diamètre intérieur.
- Couper toujours l'alimentation d'air comprimé et débrancher le flexible d'alimentation avant d'installer, déposer ou ajuster tout accessoire sur cet outil, ou d'entreprendre une opération d'entretien quelconque sur l'outil.
- Ne pas utiliser des flexibles ou des raccords endommagés, effilochés ou détériorés.
- S'assurer que tous les flexibles et les raccords sont correctement dimensionnés et bien serrés. Voir Plan TPD905-1 pour un exemple type d'agencement des tuyauteries.
- Utiliser toujours de l'air sec et propre à une pression maximum de 6,2 bar. La poussière, les fumées corrosives et/ou une humidité excessive peuvent endommager le moteur d'un outil pneumatique.
- Ne jamais lubrifier les outils avec des liquides inflammables ou volatils tels que le kérosène, le gasol ou le carburant d'aviation.
- Ne retirer aucune étiquette. Remplacer toute étiquette endommagée.
- L'utilisation d'un flexible suspendu est recommandée. Un raccord connecté directement au raccord d'admission augmente le poids de l'outil et réduit donc sa manoeuvrabilité.
- Pour obtenir les performances maximales, le raccord mural doit être d'un diamètre immédiatement supérieur à celui du raccord utilisé sur l'outil. Le raccord le plus proche de l'outil ne doit pas être inférieur au diamètre du flexible d'alimentation correct.

#### UTILISATION DE L'OUTIL

- Porter toujours des lunettes de protection pendant l'utilisation et l'entretien de cet outil.
- Porter toujours une protection acoustique pendant l'utilisation de cet outil.
- Tenir les mains, les vêtements flous et les cheveux longs, éloignés de l'extrémité rotative de l'outil.
- Noter la position des boutons ou du mécanisme d'inversion avant de mettre l'outil en marche de manière à savoir dans quel sens il va tourner lorsque la commande est actionnée.
- Prévoir, et ne pas oublier, que tout outil motorisé est susceptible d'à-coups brusques lors de sa mise en marche et pendant son utilisation.
- Garder une position équilibrée et ferme. Ne pas se pencher trop en avant pendant l'utilisation de cet outil. Des couples de réaction élevés peuvent se produire à, ou en dessous, de la pression d'air recommandée.
- La rotation des accessoires de l'outil peut continuer pendant un certain temps après le relâchement de la gâchette.
- Les outils pneumatiques peuvent vibrer pendant l'exploitation. Les vibrations, les mouvements répétitifs et les positions inconfortables peuvent causer des douleurs dans les mains et les bras. N'utiliser plus d'outils en cas d'inconfort, de picotements ou de douleurs. Consulter un médecin avant de recommencer à utiliser l'outil.
- Utiliser les accessoires recommandés par Mac Tools.
- N'utiliser que les douilles et les accessoires pour clés à chocs. Ne pas utiliser les douilles et accessoires (chromés) de clés manuelles.
- Les clés à chocs ne sont pas des appareils dynamométriques. Les connexions nécessitant un couple de serrage spécifique doivent être vérifiées avec un mesureur de couple après avoir été assemblées avec une clé à chocs.
- Cet outil n'est pas conçu pour fonctionner dans des atmosphères explosives.
- Cet outil n'est pas isolé contre les chocs électriques.

### NOTE

L'utilisation de rechanges autres que les pièces d'origine Mac Tools peut causer des risques d'insécurité, réduire les performances de l'outil et augmenter l'entretien, et peut annuler toutes les garanties.

Les réparations ne doivent être effectuées que par des réparateurs qualifiés autorisés. Consultez votre Centre de Service Mac Tools le plus proche.

# SIGNIFICATION DES ÉTIQUETTES D'AVERTISSEMENT

## ATTENTION

LE NON RESPECT DES AVERTISSEMENTS SUIVANTS PEUT CAUSER DES BLESSURES

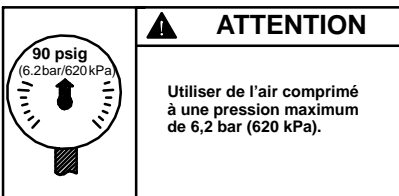
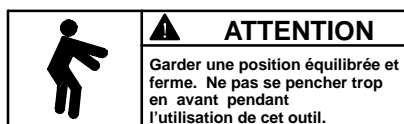
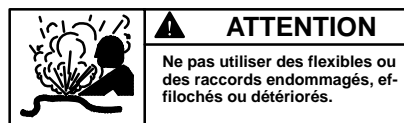
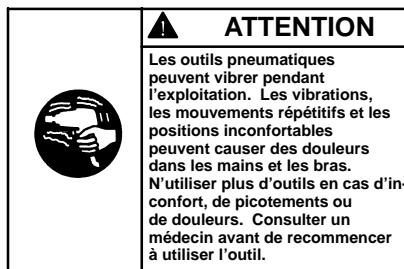
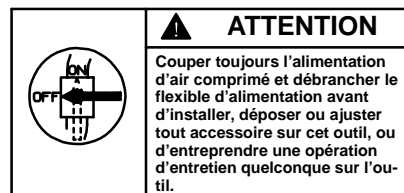
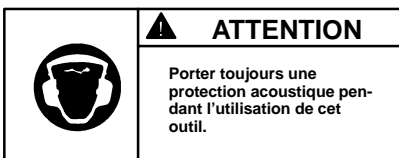
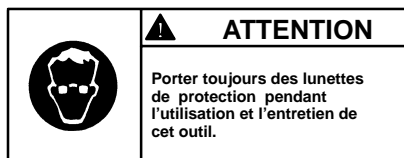

## UTILISATION DU SYSTÈME DE GESTION DE PUISSANCE

### ATTENTION

Les clés pneumatiques ne sont pas des dispositifs de contrôle de couple. Les fixations ayant des exigences spécifiques de couple doivent être contrôlées avec des dispositifs dynamométriques appropriés après avoir été assemblées avec une clé pneumatique.

La clé à chocs Modèle AW7500 est équipée d'un système de gestion de puissance qui permet à l'opérateur de sélectionner quatre réglages de puissance. Ces réglages vont de la puissance minimum à la puissance maximum en marche avant seulement.

La clé pneumatique fonctionnera toujours à la puissance maximum en desserrage, quel que soit le niveau de puissance sélectionné.

### SYSTÈME DE GESTION DE PUISSANCE MODÈLE AW7500

INDICATEURS DE RÉGLAGE DE PUISSANCE

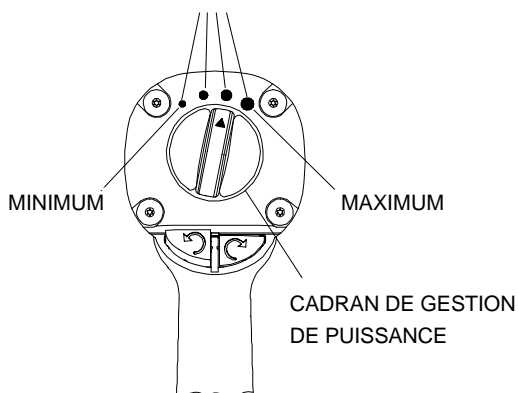

(Plan TPD2035)

### ATTENTION

Les quatre indicateurs de réglage de puissance de taille croissante sur l'arrière du corps indiquent les niveaux croissants de puissance à titre de référence seulement, et NE DÉNOTE PAS une puissance spécifique. Le plus petit indicateur de puissance indique la puissance minimum, les deux indicateurs du centre indiquent des puissances moyennes, et le plus gros indicateur indique la puissance maximum.

La puissance peut être encore plus réduite en serrage ou desserrage à l'aide de la commande variable de mise en marche. Les circuits d'air comprimé ne fournissant pas une pression d'air adéquate peuvent affecter la puissance fournie à toutes les positions de réglage.

# MISE EN SERVICE DE L'OUTIL

## LUBRIFICATION



### Mac Tools Pneumatic



Mac Tools Pneumatic pour une lubrification extérieure normale du mécanisme de chocs par l'intermédiaire du raccord de graissage du carter de marteau.

Mac Tools Pneumatic pour le démontage et l'assemblage du mécanisme de chocs.

Utiliser toujours un lubrificateur avec ces outils. Nous recommandons l'emploi du filtre-régulateur-lubrificateur suivant:

É.U. – No. C18-03-FKG0-28

International – No. C18-C3-FKG0

## AVERTISSEMENT

Ne pas marquer les codes d'identification client sur les surfaces non métalliques de cet outil. De telles actions pourraient affecter les performances de l'outil.

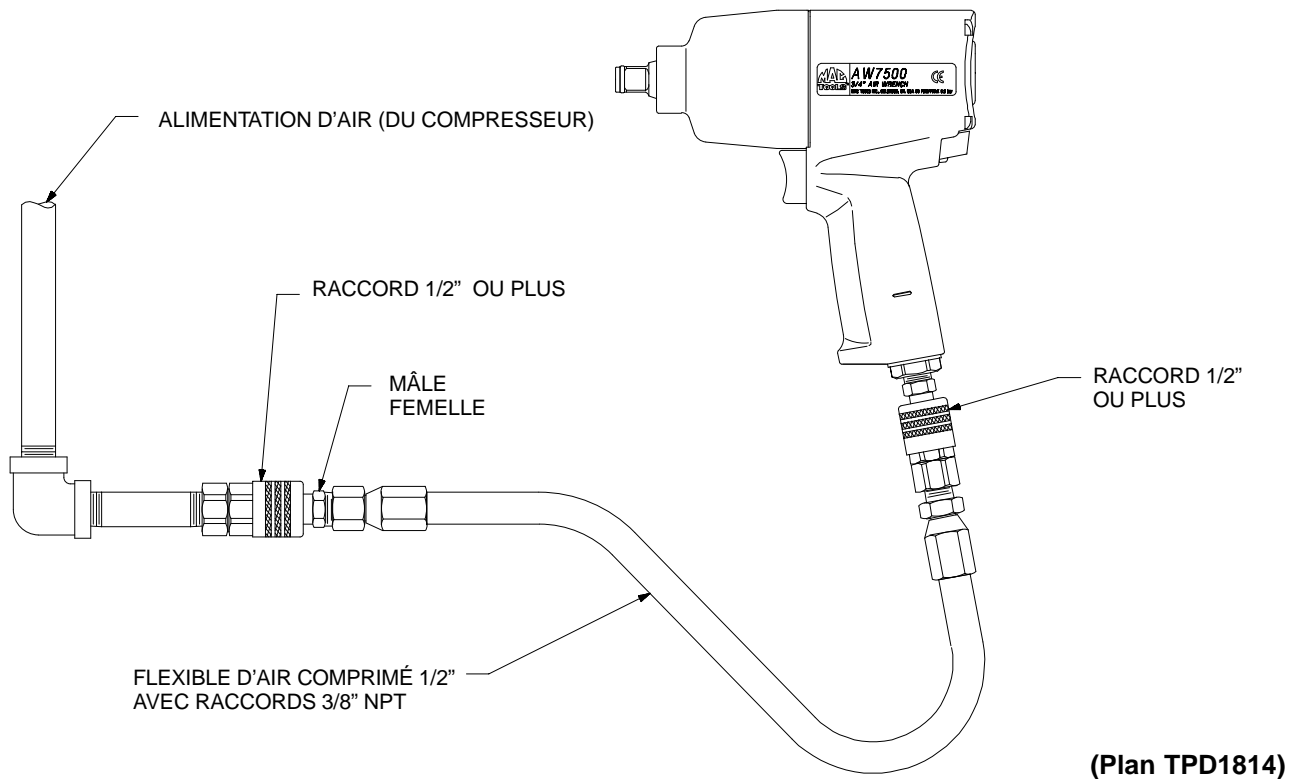
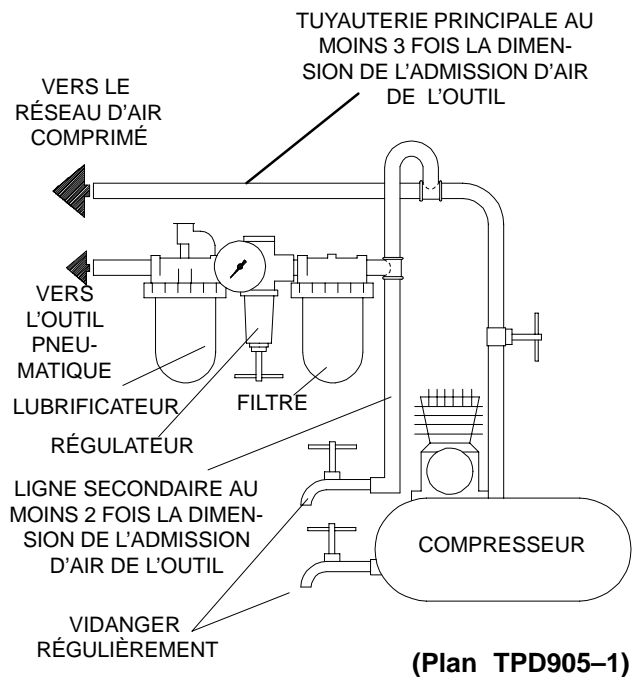



# MISE EN SERVICE DE L'OUTIL

## SPÉCIFICATIONS

Modèle	Type de Poignée	Entraînement	Coups par minute	Gamme de couples recommandée	
				Marche avant ft-lb (Nm)	Marche arrière ft-lb (Nm)
AW7500	poignée pistolet	3/4"	1.175	200-900 [1100 max.] (271-1220 [1492 max.] )	200-900 [1200 max.] (271-1220 [1627 max.] )

Modèle	■ Niveau de son dB (A)		◆ Niveau de vibration
	Pression	Puissance	m/s <sup>2</sup>
AW7500	102,9	115,9	5,9

- Test selon PNEUROP PN8NTC1.2
- ◆ Testé conformément à ISO8662-7 chargé avec frein à friction à 9 tours par minute

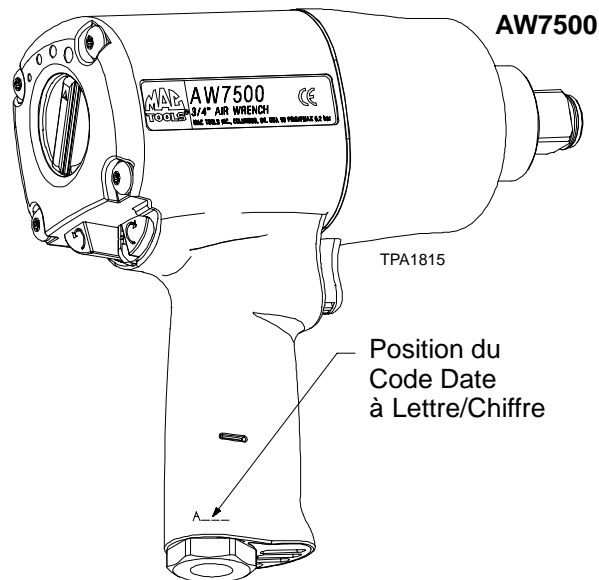

## CERTIFICAT DE CONFORMITÉ

Nous Mac Tools  
(nom du fournisseur)

Columbus, OHIO 43232 USA  
(adresse)

déclarons sous notre seule responsabilité que le produit:

Clé à Chocs Automobiles Série Ultra Forte Modèle AW7500

objet de ce certificat, est conforme aux prescriptions des Directives:

98/37/CE

en observant les normes de principe suivantes: ISO8662, PNEUROP PN8NTC1

N°. Serie: (2000 →) A00H XXXXX →

Bill Mark  
Bill Mark  
Nom et signature des chargés de pouvoir

Septembre, 2000  
Date

### NOTE

CONSERVEZ SOIGNEUSEMENT CES INSTRUCTIONS. NE PAS LES DÉTRUIRE.

A la fin de sa durée de vie, il est recommandé de démonter l'outil, de dégraisser les pièces et de les séparer en fonction des matériaux de manière à ce que ces derniers puissent être recyclés.

# BEDIENUNGSANLEITUNG FÜR ULTRA-HOCHLEISTUNGS-SCHLAGSCHRAUBER DER BAUREIHE AW7500

## HINWEIS

Die Höchstleistungs-Schlagschrauber der Baureihen AW7500 werden für allgemeine Wartungsarbeiten an Lastkraftwagen und Geländefahrzeugen, Bussen und landwirtschaftlichen Geräten eingesetzt.

Mac Tools lehnt jede Haftung für Veränderungen an Werkzeugen ab, die ohne vorherige Rücksprache mit Mac Tools vorgenommen werden.

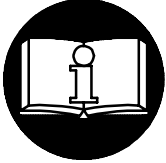

## ⚠ ACHTUNG

**NACHFOLGEND WICHTIGE SICHERHEITSHINWEISE.  
DIESE BETRIEBSANWEISUNG VOR INBETRIEBNAHME DES WERKZEUGES  
UNBEDINGT LESEN.**

**DER ARBEITGEBER IST VERPFLICHTET, DIE IN DIESEM HANDBUCH GEBEBENEN  
INFORMATIONEN DEM BEDIENER ZUGÄNGLICH ZU MACHEN.  
DIE NICHTEINHALTUNG DIESER WARNHINWEISE KANN ZU VERLETZUNGEN FÜHREN.**

### INBETRIEBNAHME DES WERKZEUGES

- Das Werkzeug stets nach den örtlich und landesweit geltenden Vorschriften für handgehaltene/handbetriebene Druckluftwerkzeuge betreiben.
- Zur Erzielung höchster Sicherheit, Leistung und Haltbarkeit der Teile sollte dieses Werkzeug mit einem maximalen Luftdruck von 6,2 bar/620 kPa am Lufteinlaß und einem Luftzufuhrschlauch 13 mm Innendurchmesser betrieben werden.
- Vor Montage, Demontage oder Verstellung von Aufsatzteilen bzw. Wartung dieses Werkzeuges die Druckluftversorgung allseitig abschalten und Druckluftschlauch abschließen.
- Keine beschädigten, durchgescheuerten oder abgenutzten Luftschläuche und Anschlüsse verwenden.
- Darauf achten, daß alle Schläuche und Anschlüsse die passende Größe haben und korrekt befestigt sind. In Zeichnung TPD905-1 ist eine typische Rohrleitungsanordnung abgebildet.
- Stets saubere, trockene Luft verwenden und einen Luftdruck von 6,2 bar verwenden. Staub, ätzende Dämpfe und/oder Feuchtigkeit können den Motor eines Druckluftwerkzeuges beschädigen.
- Die Werkzeuge nicht mit brennbaren oder flüchtigen Flüssigkeiten wie Kerosin und Diesel schmieren.
- Keine Schilder entfernen. Beschädigte Schilder austauschen.
- Einsatz eines Schlauchschutzes wird empfohlen. Wird direkt am Lufteinlaß ein Kuppler angeschlossen, so wird dadurch die Werkzeugmasse größer und die Werkzeugmanövrierfähigkeit reduziert.
- Um maximale Leistung zu gewährleisten, muß der Koppler an der Wand gegenüber dem am Werkzeug eingesetzten Koppler um eine Stufe größer sein. Der dem Werkzeug am nächsten gelegene Koppler darf nicht kleiner sein als der jeweilige Luftzufuhrschlauch.

### WERKZEUGEINSATZ

- Beim Betreiben oder Warten dieses Werkzeuges stets Augenschutz tragen.
- Beim Betreiben dieses Werkzeuges stets Gehörschutz tragen.
- Hände, lose Bekleidungsstücke und lange Haare vom rotierenden Ende des Werkzeuges fernhalten.
- Vor der Inbetriebnahme auf die Stellung der Umsteuertasten oder des Umsteuermechanismus achten, damit bei Betätigung der Drossel die Drehrichtung schon bekannt ist.
- Bei Start und Betrieb eines Werkzeuges auf Rückschlag achten und darauf vorbereitet sein.
- Während des Betriebes für festen Halt sorgen und den Körper nicht zu weit vorlehnen. Bei Betrieb mit empfohlenem oder niedrigerem Luftdruck können hohe Reaktionsdrehmomente auftreten.
- Nach dem Loslassen des Drückers kann die Welle des Werkzeuges noch kurz weiterdrehen.
- Druckluftbetriebene Werkzeuge können während des Betriebs vibrieren. Vibrationen, häufige gleichförmige Bewegungen oder unbequeme Positionen können schädlich für Hände und Arme sein. Bei Unbehagen, Kribbeln oder Schmerzen das Werkzeug nicht mehr benutzen. Vor dem erneuten Arbeiten mit dem Werkzeug ärztliche Hilfe aufsuchen.
- Stets von Mac Tools empfohlenes Zubehör verwenden.
- Nur Schlagschrauber-Steckschlüssel und -Zubehör verwenden. Keine Hand-Steckschlüssel (Chrom) oder -Zubehör verwenden.
- Schlagschrauber sind keine Drehmomentschrauber. Verbindungen, die ein bestimmtes Drehmoment erfordern, müssen nach dem Anziehen mit dem Schlagschrauber mit Hilfe eines Drehmomentmeßgerätes überprüft werden.
- Das Werkzeug ist nicht für die Arbeit in explosiven Atmosphären geeignet.
- Dieses Werkzeug ist nicht gegen elektrischen Schlag isoliert.

## HINWEIS

Die Verwendung von nicht Original-Mac Tools-Ersatzteilen kann Sicherheitsrisiken, verringerte Standzeit und erhöhten Wartungsbedarf nach sich ziehen und alle Garantieleistungen ungültig machen.

Reparaturen sollen nur von geschultem Personal durchgeführt werden. Wenden Sie sich an Ihre nächste Mac Tools-Niederlassung oder den autorisierten Fachhandel.

# ANWEISUNGEN AUF WARNSCHILDERN

## ⚠ ACHTUNG

DIE NICHTEINHALTUNG DIESER WARNHINWEISE KANN ZU VERLETZUNGEN FÜHREN.

	<b>⚠ ACHTUNG</b>
	Beim Betreiben oder Warten dieses Werkzeuges stets Augenschutz tragen.

	<b>⚠ ACHTUNG</b>
	Beim Betreiben dieses Werkzeuges stets Gehörschutz tragen.

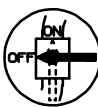
	<b>⚠ ACHTUNG</b>
	Vor Wartungsarbeiten oder dem Austausch von Zubehör ist das Werkzeug von der Druckluftversorgung abzuschalten.

	<b>⚠ ACHTUNG</b>
	Druckluftbetriebene Werkzeuge können während des Betriebs vibrieren. Vibrationen, häufige gleichförmige Bewegungen oder unbequeme Positionen können schädlich für Hände und Arme sein. Bei Unbehagen, Kribbeln oder Schmerzen das Werkzeug nicht mehr benutzen. Vor dem erneuten Arbeiten mit dem Werkzeug ärztliche Hilfe suchen.

	<b>⚠ ACHTUNG</b>
	Das Werkzeug nicht am Schlauch tragen.

	<b>⚠ ACHTUNG</b>
	Keine beschädigten, durchgescheuerten oder abgenutzten Luftschläuche und Anschlüsse verwenden.

	<b>⚠ ACHTUNG</b>
	Während des Betriebens für festen Halt sorgen und den Körper nicht zu weit nach vorne beugen.

	<b>⚠ ACHTUNG</b>
	Mit einem maximalen Luftdruck von 6,2 bar/620 kPa (90 psig) betreiben.

## EINSATZ DES LEISTUNGSSTEUERUNGS-SYSTEMS

### ⚠ ACHTUNG

Druckluftschrauber sind nicht drehmomentkontrolliert. Befestigungselemente mit bestimmten Drehmomentanforderungen müssen nach der Installation durch einen Druckluftschrauber mit Hilfe eines geeigneten Drehmoment-Meßgerätes überprüft werden.

Schlagschrauber der Modell AW7500 verfügen über ein Leistungssteuerungs-System, mit Hilfe dessen der Bediener vier verschiedene Leistungseinstellungen vornehmen kann. Die Einstellungen reichen bei Vorwärtsrichtung von minimaler bis maximaler Leistung. **In Umkehrrichtung arbeitet der Druckluftschrauber stets mit maximaler Leistung, unabhängig von der mit dem Drehknopf eingestellten Leistung.**

### MODELL AW7500 LEISTUNGSSTEUERUNGS-SYSTEM

ANZEIGEPUNKTE FÜR DIE LEISTUNGSEINSTELLUNG

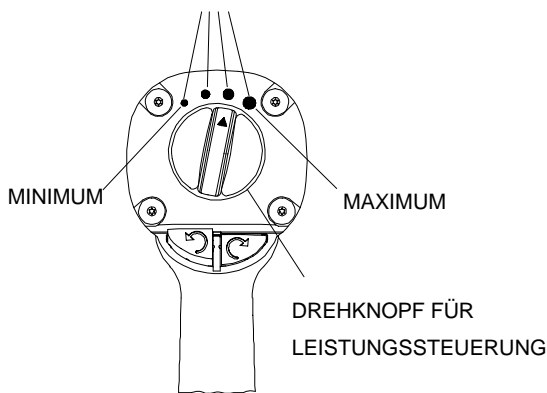

(Zeichn. TPD2035)

### ⚠ ACHTUNG

Die vier Anzeigepunkte für die Leistungseinstellung in zunehmender Größe hinten auf dem Gehäuse bedeuten höhere Leistung. Sie dienen jedoch lediglich der Referenz und **GEBEN NICHT** bestimmte Leistungswerte an. Der kleinste Anzeigepunkt steht für minimale Leistung, die beiden mittleren für mittlere Leistung und der größte Anzeigepunkt für maximale Leistung des Werkzeuges. Die abgegebene Leistung kann durch den Einsatz einer verstellbaren Drossel in Vorwärts- oder Rückwärtsrichtung zusätzlich verringert werden. Luftzufuhrsysteme, die nicht den angemessenen Luftdruck liefern, können bei allen Einstellungen Einfluß auf die Leistung haben.

# INBETRIEBNAHME DES WERKZEUGES

## SCHMIERUNG



Mac Tools Pneumatic Öl



Zur routinemäßigen, externen Schmierung des Schlagwerkes (am Hammergehäuse-Schmiernippel) **Mac Tools Pneumatic Öl** verwenden.

Bei Zerlegung und Zusammenbau des Schlagwerkes **Mac Tools Pneumatic Öl** verwenden.

Das Werkzeug stets mit einem Leitungsoiler verwenden. Es wird folgende Filter-Regler-Öler-Kombination empfohlen:

USA Nr: C18-03-FKG0-28

Ingersoll-Rand Nr: C18-C3-FKG0

## VORSICHT

Die nicht-metallische Oberfläche des Werkzeugs ist keinesfalls mit Kunden-Identifikations-Merkmalen zu versehen. Dies kann die Leistung des Werkzeugs beeinträchtigen.

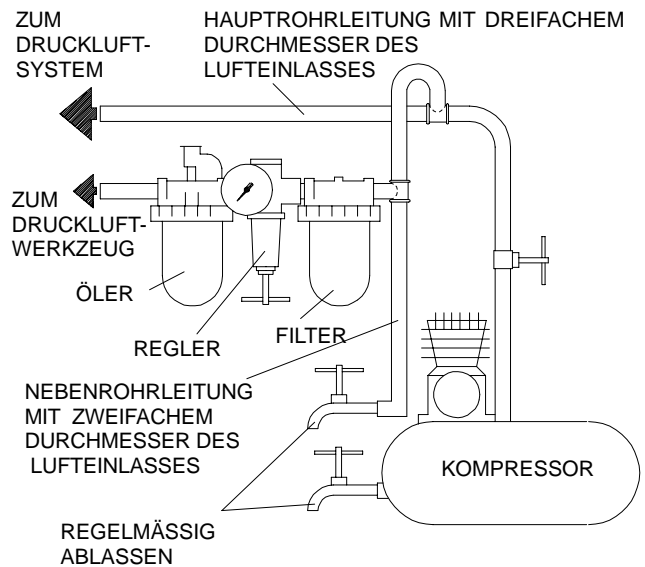

(Zeichn. TPD905-1)

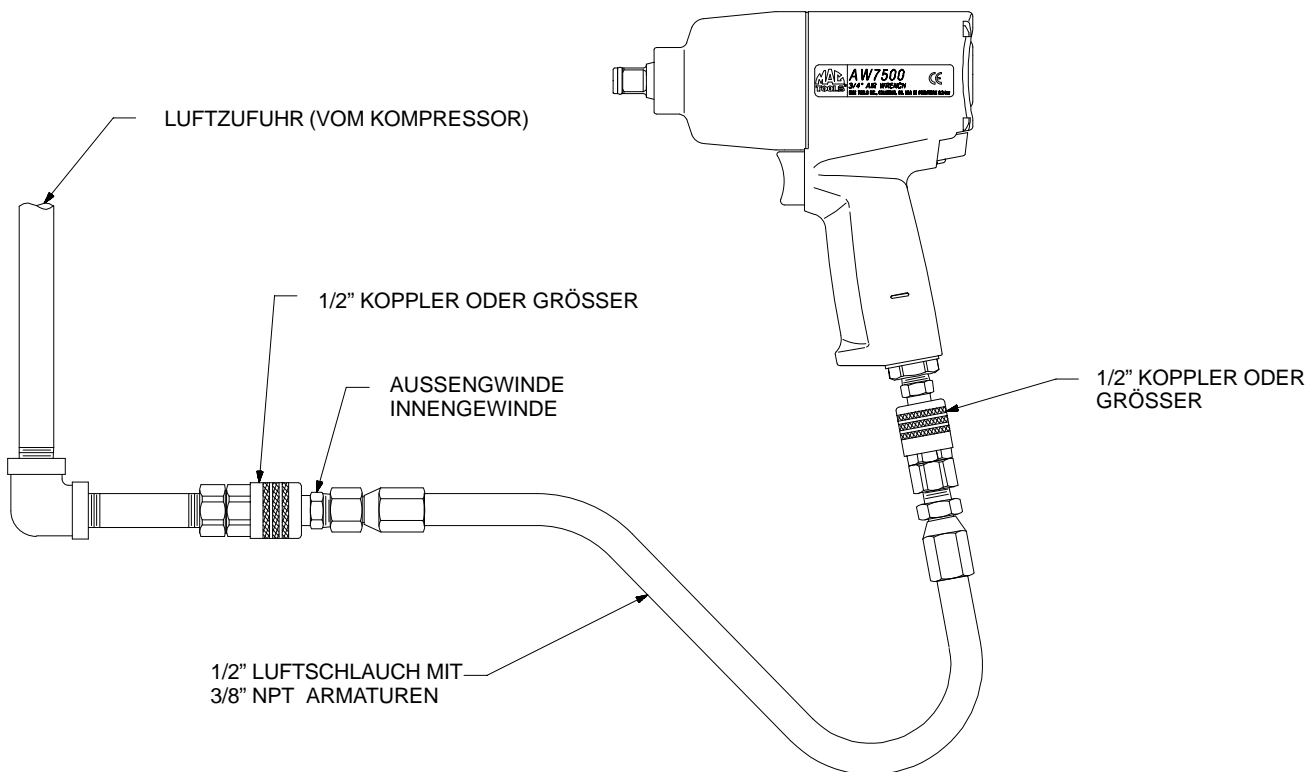

(Zeichn. TPD1814)

# INBETRIEBNAHME DES WERKZEUGES

## TECHNISCHE DATEN

Modell	Griffart	Antrieb	Schläge/ Minute	Empfohlenes Arbeitsdrehmoment	
				Vorwärts ft-lb (Nm)	Rückwärts ft-lb (Nm)
AW7500	Pistolengriff	3/4"	1.175	200–900 [1100 max] (271–1220 [1492 max] )	200–900 [1200 max] (271–1220 [1627 max] )

Modell	■Schallpegel dB (A)		◆Schwin- gungs- intensität
	Druck	Leistung	m/s <sup>2</sup>
AW7500	102,9	115,9	5,9

- Gemäß PNEUROP PN8NTC1.2 geprüft
- ◆ Nach ISO8662–7 mit Reibungsbremse auf 9 U/min. getestet

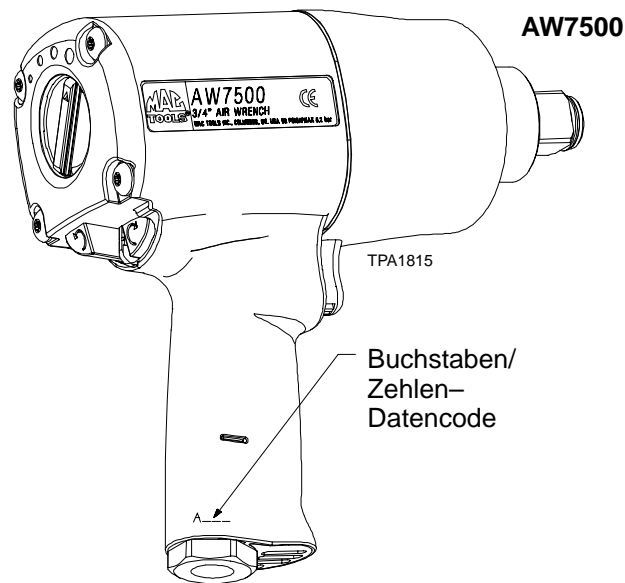

## KONFORMITÄTSERKLÄRUNG

**Wir**

**Mac Tools**

(Name des Herstellers)

**Columbus, OHIO 43232 USA**

(Adresse)

erklären hiermit, gemäß unserer alleinigen Verantwortung, daß die Geräte:

**Ultra-Hochleistungs-Schlagschrauber der Baureihe AW7500**

auf die sich diese Erklärung bezieht, den Richtlinien:

**98/37/EG**

unter Anlehnung an die folgenden Grundnormen

entsprechen: **ISO8662, PNEUROP PN8NTC1**

Serien-Nr.-Bereich: **(2000 → ) A00H XXXXX →**

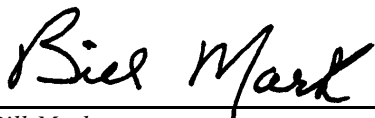

Bill Mark

Name und Unterschrift der Bevollmächtigten

**September, 2000**

Datum

### HINWEIS

**DIESE ANWEISUNGEN SIND SORGFÄLTIG AUFZUBEWAHREN. NICHT ZERSTÖREN.**

Zur Entsorgung ist das Werkzeug vollständig zu demontieren, zu entfetten und nach Materialarten getrennt der Wiederverwertung zuzuführen.

**ISTRUZIONI PER CHIAVE AD IMPULSI  
ULTRA DUTY PER AUTOMOTIVE  
MODELLO AW7500****AVVISO**

Le chiavi ad impulsi modello AW7500 Ultra Duty è state progettate per operazioni di manutenzione generica di camion stradali e fuori strada, autobus e macchine agricole. La Mac Tools non è responsabile delle modifiche apportate alle pompe dai clienti per adattarli ad applicazioni per le quali la Mac Tools non sia stata interpellata.

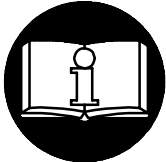
**AVVERTENZA**

**IMPORTANTE INFORMAZIONE DI SICUREZZA ACCLUSA.  
LEGGERE IL PRESENTE MANUALE PRIMA DI USARE L'ATTREZZO.  
È RESPONSABILITÀ DEL DATORE DI LAVORO DI METTERE QUEST'INFORMAZIONE  
NELLE MANI DELL'OPERATORE.  
LA MANCATA OSSERVANZA DELLE SEGUENTI AVVERTENZE PUÒ CAUSARE  
LESIONI FISICHE.**

**MESSA IN SERVIZIO DELL'ATTREZZO**

- Usare, ispezionare e mantenere sempre quest'attrezzo secondo tutti i regolamenti (locali, statali, federali e nazionale), che possano essere applicabili agli attrezzi a mano pneumatici.
- Per sicurezza, massime prestazioni e massima durabilità delle parti, usare quest'attrezzo ad una massima pressione d'aria di 90 psig (6,2 bar/ 620 kPa) all'ingresso con un flessibile di alimentazione dell'aria con diametro interno di 1/2" (13 mm).
- Disinserire sempre l'alimentazione aria e staccare il relativo tubo dall'attrezzo, prima di installare, togliere o regolare qualsiasi accessorio, oppure prima di eseguire qualsiasi operazione di manutenzione dell'attrezzo.
- Non adoperare tubi e raccordi danneggiati, consunti o deteriorati.
- Assicurarsi che tutti i tubi ed i raccordi siano delle corrette dimensioni e saldamente serrati. Consultare il disegno TPD905-1 per una tipica disposizione dei tubi.
- Usare sempre aria pulita ed asciutta alla pressione max di 90 psig. Polvere, fumi corrosivi e/o un eccesso di umidità possono rovinare il motore di un attrezzo pneumatico.
- Non lubrificare gli utensili con liquidi infiammabili o volatili come kerosene, gasolio o combustibile per aviogetti.
- Non togliere nessuna etichetta. Sostituire eventuali etichette danneggiate.
- Si consiglia l'uso di un segmento di flessibile. Un raccordo collegato direttamente all'ingresso dell'aria aumenta il volume dell'attrezzo e ne diminuisce la manovrabilità.
- Per massime prestazioni, il raccordo sul muro deve essere della successiva dimensione maggiore di quella del raccordo sull'attrezzo. Il raccordo più vicino all'attrezzo non deve essere inferiore alla corretta dimensione del flessibile dell'alimentazione dell'aria.

**COME USARE L'ATTREZZO**

- Indossare sempre degli occhiali protettivi quando si adoperano questo attrezzo o se ne esegue la manutenzione.
- Indossare sempre delle cuffie protettive quando si adoperano questo attrezzo.
- Tenere le mani, gli indumenti sciolti ed i capelli lunghi distanti dall'estremità battente dell'attrezzo.
- Notare la posizione del pulsante o meccanismo di reversibilità prima di azionare l'attrezzo in modo da essere consci della direzione di rotazione quando si aziona il grilletto.
- Fare attenzione e cercare di anticipare improvvisi di azioni di movimento durante l'avviamento e l'uso di qualsiasi utensile pneumatico.
- Nell'usare l'attrezzo, mantenere con il corpo una posizione salda e ben bilanciata. Non sbilanciarsi durante l'uso di questo attrezzo. Delle elevate reazioni di coppia si possono verificare alla pressione d'aria raccomandata o inferiore.
- Gli accessori dell'utensile potrebbe continuare a funzionare brevemente dopo che è stata disinserita l'immissione.
- Gli attrezzi pneumatici possono vibrare durante l'uso. Le vibrazioni, i movimenti ripetitivi o le posizioni scomode possono risultare dannosi per le mani e le braccia. Interrompere l'uso dell'utensile se si avvertono sintomi di disagio fisico, formicolio o dolore. Interpellare un medico prima di riprendere il lavoro.
- Usare accessori raccomandati dalla Mac Tools.
- Usare solo boccole ed accessori ad impulso. Non usare boccole a mano (cromate) o accessori.
- Le chiavi ad impulsi non sono chiavi torsionometriche. Collegamenti che richiedono specifiche coppie devono essere controllati con un torsionometro l'installazione con una chiave torsionometrica.
- Questo utensile non è stato progettato per operare in atmosfere esplosive.
- Questo utensile non è isolato contro le scosse elettriche.

**AVVISO**

L'uso di ricambi non originali Mac Tools potrebbe causare condizioni di pericolosità, compromettere le prestazioni dell'attrezzo ed aumentare la necessità di manutenzione, inoltre potrebbe invalidare tutte le garanzie.

Le riparazioni devono essere effettuate soltanto da personale autorizzato e qualificato. Rivolgersi al più vicino centro di assistenza tecnica Mac Tools.



## IDENTIFICAZIONE DELLE ETICHETTE DI AVVERTENZA

### ⚠ AVVERTENZA

LA MANCATA OSSERVANZA DELLE SEGUENTI AVVERTENZE PUÒ CAUSARE LESIONI FISICHE.

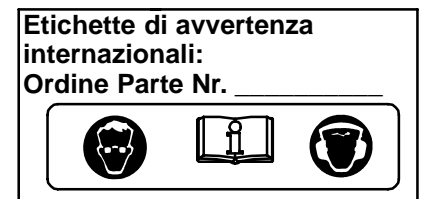
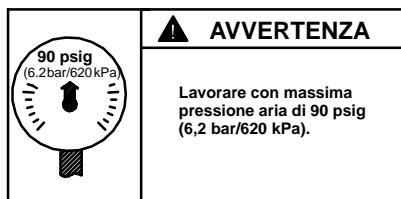
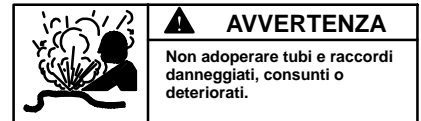
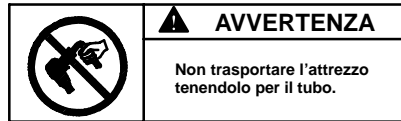
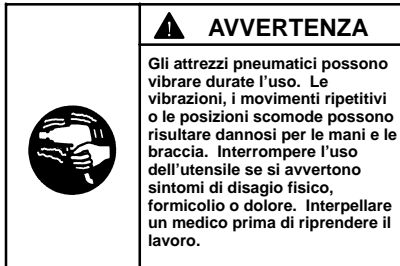
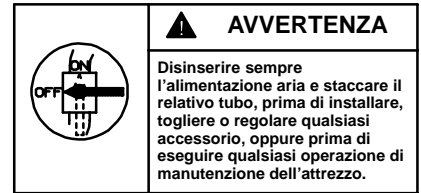
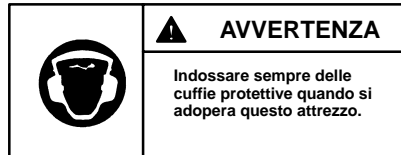
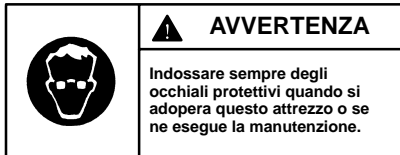

## COME UTILIZZARE IL SISTEMA DI GESTIONE DI POTENZA

### ⚠ AVVERTENZA

Le chiavi pneumatiche non sono dispositivi di controllo della coppia. Attrezzi di fissaggio con specifici requisiti di coppia devono essere controllati con appositi dispositivi di misurazione di coppia dopo l'installazione con una chiave pneumatica.

Le chiavi ad impulsi modello AW7500 incorporano un sistema di gestione di potenza che consente all'operatore di selezionare quattro valori di erogazione di potenza. Tali valori vanno dall'erogazione minima di potenza fino alla massima solamente in avvitatura. La chiave pneumatica funzionerà alla massima potenza in svitatura, senza tener conto di quale regolazione sia stata impostata.

### SISTEMA DI GESTIONE DI POTENZA MODELLO AW7500

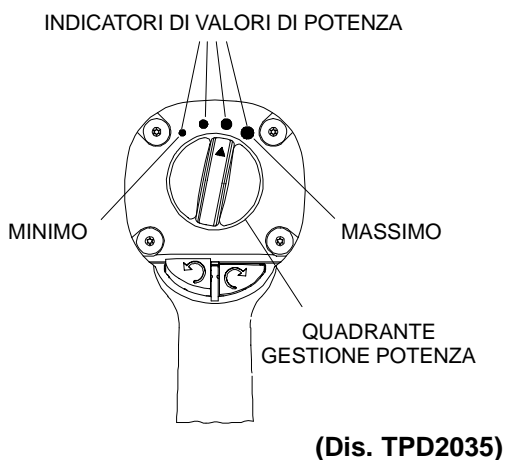

### ⚠ AVVERTENZA

I quattro valori dell'indicatore di potenza di dimensioni crescenti, posti sul retro della cassa, indicano i livelli di aumento di erogazione di potenza e valgono solo per riferimento e NON denotano una specifica erogazione di potenza. Il più piccolo indicatore di regolazione di potenza indica la minima erogazione di potenza, i due indicatori nel mezzo denotano erogazioni di potenza medie e quello più grande denota massima erogazione di potenza. L'erogazione di potenza può essere ridotta ulteriormente in entrambe le direzioni utilizzando la leva d'immissione variabile. Impianti di alimentazione d'aria che non producono adeguata pressione potrebbero influenzare negativamente l'erogazione di potenza a tutte le regolazioni.

# MESSA IN SERVIZIO DELL'ATTREZZO

## LUBRIFICAZIONE



### Mac Tools Pneumatic



Usare **Mac Tools Pneumatic** per lubrificazione esterna di routine del meccanismo dell'attrezzo ad impulsi attraverso l'ingrassatore posto sulla cassa del martello.

Usare **Mac Tools Pneumatic** quando si smonta e si monta il meccanismo ad impulsi.

Con questi attrezzi usare sempre un lubrificatore di linea. Si raccomanda l'uso del seguente gruppo filtro-regolatore-lubrificatore:

per gli USA – Nr. C18-03-FKG0-28  
per gli altri paesi – C18-C3-FKG0

## ATTENZIONE

Non contrassegnare alcuna superficie non metallica su questo attrezzo con i codici di identificazione del cliente. Ciò potrebbe compromettere le prestazioni dell'attrezzo.

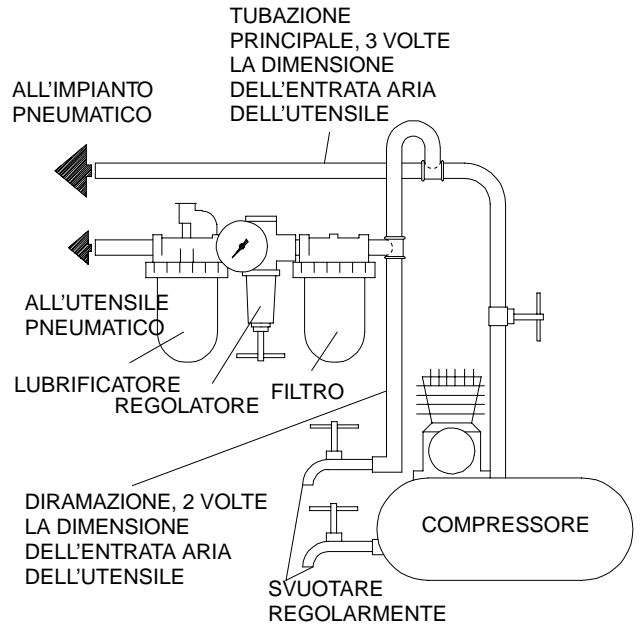

(il disegno TPD905-1)

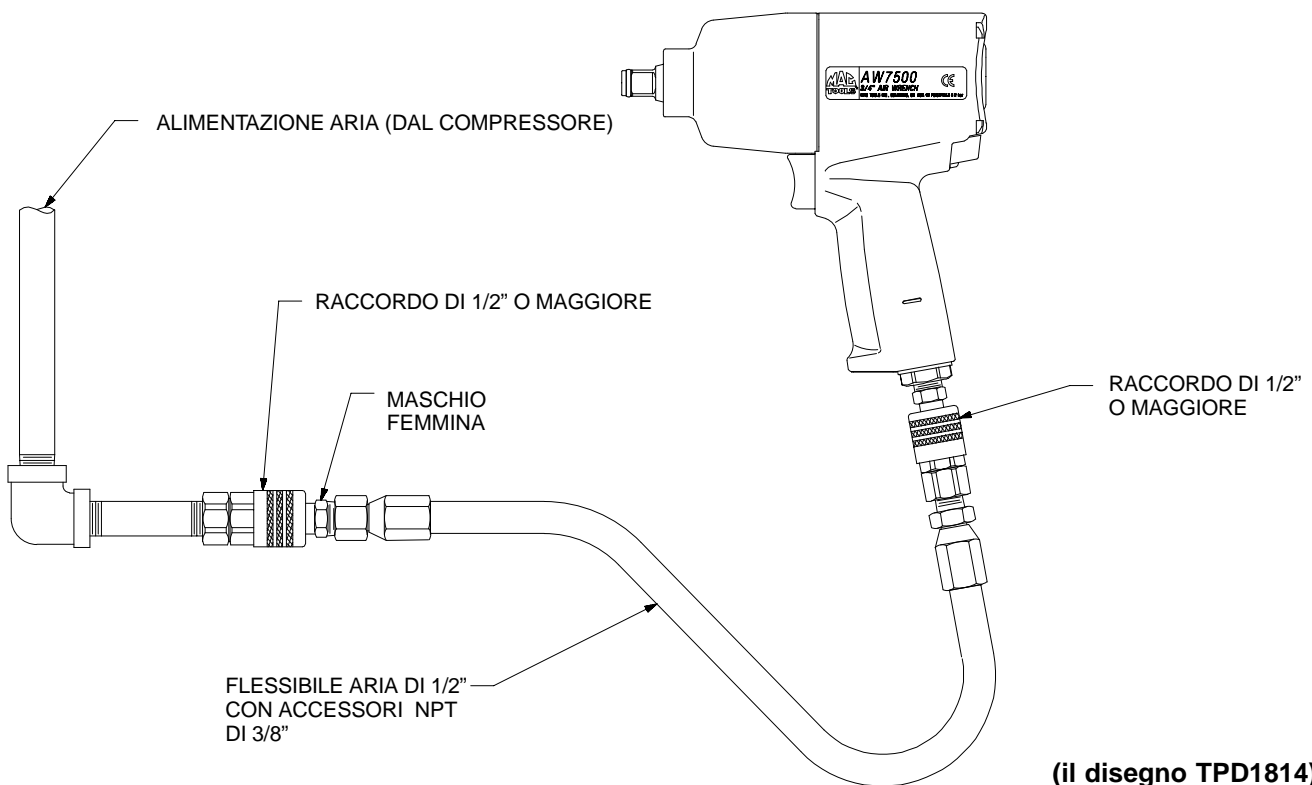

(il disegno TPD1814)

## MESSA IN SERVIZIO DELL'ATTREZZO

### SPECIFICA

Modello	Tipo d'impugnatura	Attacco	Impulsi/min.	Gamma di coppia consigliata	
				Avanti ft-lb (Nm)	Inverso ft-lb (Nm)
AW7500	guangetta a pistola	3/4"	1.175	200-900 [1100 Max] (271-1220 [1492 Max] )	200-900 [1200 Max] (271-1220 [1627 Max] )

Modello	■ Livello suono dB (A)		◆ Livello di vibrazione
	Pressione	Potenza	m/s <sup>2</sup>
AW7500	102,9	115,9	5,9

- Test in conformità con PNEUROP PN8NTC1.2
- ◆ Collaudato secondo i criteri ISO8662-7 caricato di freno a frizione a 9 giri al minuto

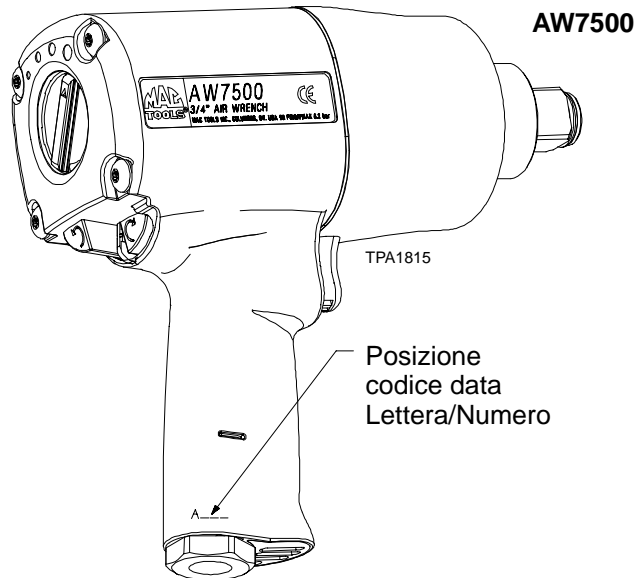

## DICHIARAZIONE DI CONFORMITÀ

Noi Mac Tools  
(nome del fornitore)

Columbus, OHIO 43232 USA

(indirizzo)

dichiariamo sotto la nostra unica responsabilità che il prodotto:

Chiave ad impulsi Ultra Duty per Automotive modello AW7500

a cui si riferisce la presente dichiarazione è conforme alle normative delle direttive:

98/37/CE

secondo i seguenti standard: ISO8662, PNEUROP PN8NTC1

Numeri di Serie: (2000 → ) A00H XXXXX →

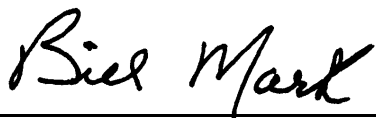

Bill Mark

Nome e firma delle persone autorizzate

Settembre, 2000

Data

### AVVISO

CONSERVARE QUESTE ISTRUZIONI. NON DISTRUGGERLE.

Quando l'attrezzo diventato inutilizzabile, si raccomanda di smontarlo, sgrassarlo e separare i componenti secondo i materiali in modo da poterli riciclare.

# INSTRUCCIONES PARA LLAVE DE IMPACTO PARA AUTOMOCIÓN DE SERVICIO ULTRA PESADO MODELO AW7500

## NOTA

La llave de impacto modelo AW7500 para servicio ultrapesado están diseñadas para trabajos generales de mantenimiento de camiones de simple o doble tracción, autobuses y maquinaria agrícola.

Mac Tools no aceptará responsabilidad alguna por la modificación de las herramientas efectuada por el cliente para las aplicaciones que no hayan sido consultadas con Mac Tools.



## ⚠ AVISO

**SE ADJUNTA INFORMACIÓN IMPORTANTE DE SEGURIDAD.  
LEA ESTE MANUAL ANTES DE UTILIZAR LA HERRAMIENTA.**

**ES RESPONSABILIDAD DE LA EMPRESA ASEGURARSE DE QUE EL OPERARIO  
ESTÉ AL TANTO DE LA INFORMACIÓN QUE CONTIENE ESTE MANUAL.**

**EL HACER CASO OMISO DE LOS AVISOS SIGUIENTES PODRÍA OCASIONAR LESIONES.**

### PARA PONER LA HERRAMIENTA EN SERVICIO

- Utilice, inspeccione y mantenga esta herramienta siempre de acuerdo con todas las normativas locales y nacionales que se apliquen a las herramientas neumáticas de utilización manual o que se sujeten con la mano.
- Para mayor seguridad, rendimiento óptimo y larga vida útil de las piezas, utilice esta herramienta a una presión de aire máxima de 90 psig (6,2 bar/ 620 kPa) con una manguera de suministro de aire con diámetro interno de 13 mm.
- Corte siempre el suministro de aire y desconecte la manguera de suministro de aire antes de instalar, desmontar o ajustar cualquier accesorio de esta herramienta, o antes de realizar cualquier operación de mantenimiento de la misma.
- No utilice mangueras de aire y racores dañados, desgastados o deteriorados.
- Asegúrese de que todos los racores y mangueras sean del tamaño correcto y estén bien apretados. El Esq. TPD905-1 muestra una disposición característica de las tuberías.
- Use siempre aire limpio y seco a una presión máxima de 90 psig (6,2 bar/620 kPa). El polvo, los gases corrosivos y el exceso de humedad pueden estropear el motor de una herramienta neumática.
- No lubrique las herramientas con líquidos inflamables o volátiles tales como queroseno, gasoil o combustible para motores a reacción.
- No saque ninguna etiqueta. Sustituya toda etiqueta dañada.
- Se recomienda la utilización de una conexión flexible para manguera de aire. Si se conecta un acoplador directamente a la salida de aire, se aumentará el volumen de la herramienta y se disminuirá su maniobrabilidad.
- Para conseguir un rendimiento óptimo, el acoplador situado en la pared deberá ser más grande, del tamaño siguiente al del acoplador utilizado en la herramienta. El acoplador más cercano a la herramienta no debe ser menor que el tamaño de la manguera de suministro de aire apropiada.

### UTILIZACIÓN DE LA HERRAMIENTA

- Lleve siempre protección ocular cuando utilice esta herramienta o realice operaciones de mantenimiento en la misma.
- Lleve siempre protección para los oídos cuando utilice esta herramienta.
- Mantenga las manos, la ropa suelta y el cabello largo alejados del extremo giratorio de la herramienta.
- Tome nota de la posición de los botones inversores o mecanismo inversor antes de hacer funcionar la herramienta para tener en cuenta el sentido de rotación al accionar el estrangulador.
- Anticipe y esté atento a los cambios repentinos en el movimiento durante la puesta en marcha y utilización de toda herramienta motorizada.
- Mantenga una postura del cuerpo equilibrada y firme. No estire demasiado los brazos al manejar la herramienta. Pueden darse elevados pares de reacción a la presión de aire recomendada, e incluso a presiones inferiores.
- El eje de la herramienta puede seguir girando brevemente después de haberse soltado el mando.
- Las herramientas neumáticas pueden vibrar durante el uso. La vibración, los movimientos repetitivos o las posiciones incómodas pueden dañarle los brazos y manos. En caso de incomodidad, sensación de hormigueo o dolor, deje de usar la herramienta. Consulte con el médico antes de volver a utilizarla.
- Utilice únicamente los accesorios Mac Tools recomendados.
- Utilice únicamente bocas y accesorios para llaves de impacto. No utilice bocas o accesorios manuales (cromados).
- Las llaves de impacto no son llaves de par. Las uniones que requieran pares específicos deberán ser comprobadas con un torsiómetro después de haberlas fijado con una llave de impacto.
- Esta herramienta no ha sido diseñada para trabajar en ambientes explosivos.
- Esta herramienta no está aislada contra descargas eléctricas.

## NOTA

El uso de piezas de recambio que no sean las auténticas piezas Mac Tools puede poner en peligro la seguridad, reducir el rendimiento de la herramienta y aumentar los cuidados de mantenimiento necesarios, así como invalidar toda garantía. Las reparaciones sólo se deben encomendar a personal debidamente cualificado y autorizado. Consulte con el centro de servicio autorizado Mac Tools más próximo.

## ETIQUETAS DE AVISO

### ⚠ AVISO

EL HACER CASO OMISO DE LOS AVISOS SIGUIENTES PODRÍA OCASIONAR LESIONES.

	<p><b>⚠ ADVERTENCIA</b></p> <p>Usar siempre protección ocular al manejar o realizar operaciones de mantenimiento en esta herramienta.</p>
---	---

	<p><b>⚠ ADVERTENCIA</b></p> <p>Usar siempre protección para los oídos al manejar esta herramienta.</p>
---	--

	<p><b>⚠ ADVERTENCIA</b></p> <p>Cortar siempre el suministro de aire y desconectar la manguera de suministro de aire antes de instalar, retirar o ajustar cualquier accesorio de esta herramienta, o antes de realizar cualquier operación de mantenimiento de la misma.</p>
---	---



	<p><b>⚠ ADVERTENCIA</b></p> <p>Las herramientas neumáticas pueden vibrar durante el uso. La vibración, los movimientos repetitivos o las posiciones incómodas podrían dañarle los brazos y las manos. En caso de incomodidad, sensación de hormigueo o dolor, dejar de usar la herramienta. Consultar al médico antes de volver a utilizarla.</p>
---	---

	<p><b>⚠ ADVERTENCIA</b></p> <p>No coger la herramienta por la manguera para levantarla.</p>
---	---

	<p><b>⚠ ADVERTENCIA</b></p> <p>No utilizar mangueras de aire y accesorios dañados, desgastados ni deteriorados.</p>
---	---

	<p><b>⚠ ADVERTENCIA</b></p> <p>Mantener una postura del cuerpo equilibrada y firme. No estirar demasiado los brazos al manejar la herramienta.</p>
---	--

	<p><b>⚠ ADVERTENCIA</b></p> <p>Manejar la herramienta a una presión de aire máxima de 90 psig (6,2 bar/620 kPa).</p>
---	--

<p><b>Etiqueta de Aviso Internacional:</b> <b>Pida Pieza N°</b></p>	
	
	

## USO DEL SISTEMA DE CONTROL DE POTENCIA

### ⚠ AVISO

Las llaves neumáticas no son dispositivos de control de par. Las fijaciones que exijan un par de apriete específico se deberán comprobar con un dispositivo apropiado de medición de par después de haberlas apretado con una llave neumática.

La llave de impacto modelo AW7500 tienen incorporado un sistema de control de potencia que permite al operario seleccionar entre cuatro ajustes de potencia. Estos ajustes van desde potencia mínima hasta potencia máxima en el sentido de giro a derechas solamente.

La llave neumática siempre funcionará con la máxima potencia en el sentido inverso, cualquiera que sea el nivel de potencia seleccionado.

### SISTEMA DE CONTROL DE POTENCIA MODELO AW7500

INDICADORES DE AJUSTE DE POTENCIA

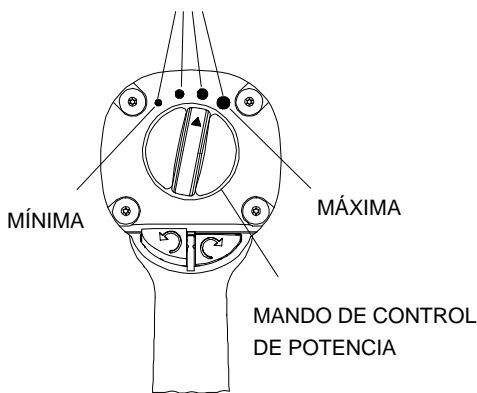

(Esq. TPD2035)

### ⚠ AVISO

Los cuatro indicadores de potencia de creciente tamaño situados en la parte posterior de la carcasa indican niveles crecientes de potencia y sirven solamente de referencia; NO indican una potencia específica. El indicador de potencia más pequeño señala la potencia mínima, los dos indicadores de potencia intermedios señalan potencias intermedias y el indicador más grande representa la máxima potencia. La potencia puede reducirse aun más con accionamiento a derechas o a izquierdas mediante el gatillo de mando. Los sistemas de aire comprimido que no suministren aire a la presión apropiada pueden afectar la potencia en todos los ajustes.

# PARA PONER LA HERRAMIENTA EN SERVICIO

## LUBRICACIÓN



### Mac Tools Pneumatic



Utilice **Mac Tools Pneumatic** para lubricación externa periódica del mecanismo impulsor a través del engrasador de la carcasa de mazas.

Utilice **Mac Tools Pneumatic** al montar y desmontar el mecanismo de impacto.

Utilice siempre un lubricante de aire comprimido con esta herramienta. Recomendamos utilizar el siguiente conjunto de filtro-lubricador-regulador:

Para EE.UU. – N° C18-03-FKG0-28  
Internacional – C18-C3-FKG0

### PRECAUCIÓN

No marque ninguna superficie no metálica de esta herramienta con los códigos de identificación del cliente. Tal acción podría afectar al rendimiento de la herramienta.

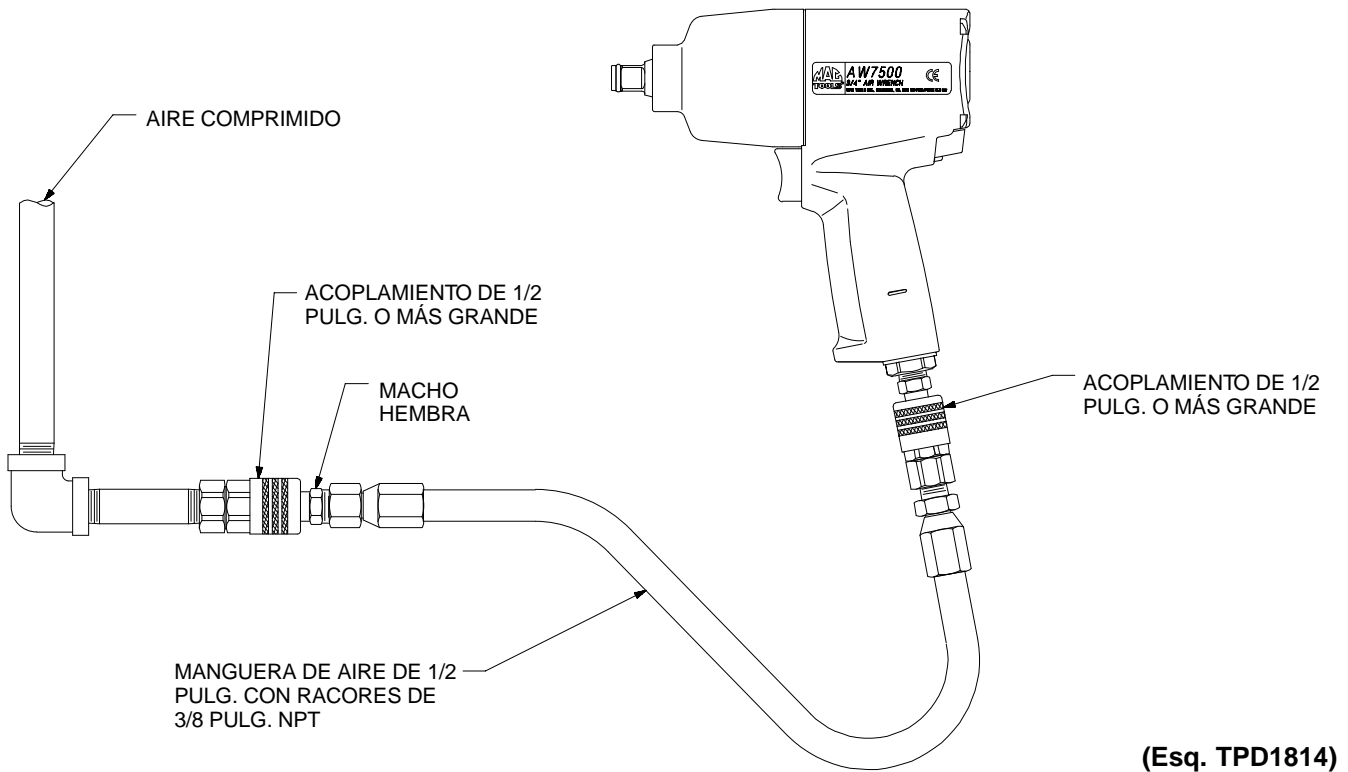
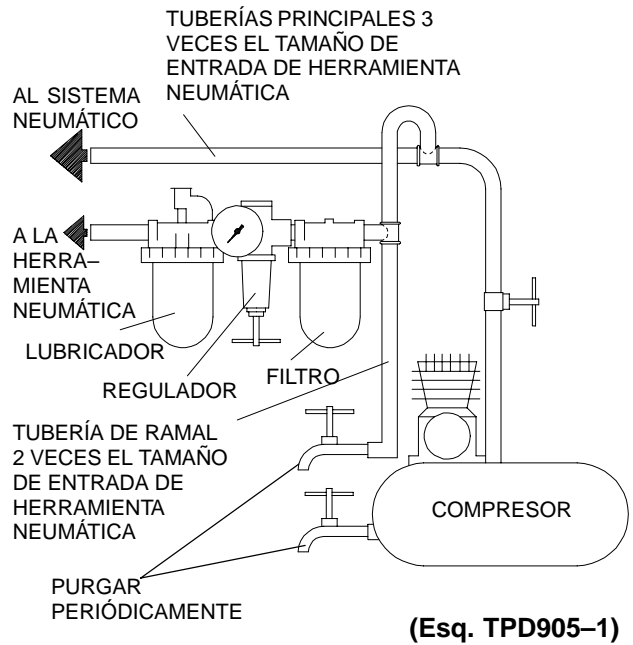

## PARA PONER LA HERRAMIENTA EN SERVICIO

### ESPECIFICACIONES

Modelo	Tipo de empuñadura	Accionamiento	Impactos por minuto	Gama de par recomendada	
				Hacia delante ft-lb Nm	Inversa ft-lb Nm
AW7500	Empuñadura de pistola	3/4 pulg.	1.175	200–900 [1100 Máx] (271–1220 [1492 Máx] )	200–900 [1200 Máx] (271–1220 [1627 Máx] )

Modelo	■ Nivel de sonido dB (A)		◆ Nivel de vibraciones
	Presión	Potencia	m/s <sup>2</sup>
AW7500	102,9	115,9	5,9

- Comprobado conforme a la norma PNEUROP PN8NTC1.2
- ◆ Probado a ISO8662–7 cargado con freno de fricción a 9 RPM





**DECLARACION DE CONFORMIDAD**

*Los abajo firmantes* Mac Tools  
(nombre del proveedor)

Columbus, OHIO 43232 USA  
(domicilio)

*Declaramos que, bajo nuestra responsabilidad exclusiva, el producto:*

Llaves de Impacto para Automoción de Servicio Ultra Pesado Modelo AW7500

*a los que se refiere la presente declaración, cumplen con todo lo establecido en las directivas:*

98/37/CE

*conforme a los siguientes estándares:* ISO8662, PNEUROP PN8NTC1

*Gama de No. de Serie:* (2000 → ) A00H XXXXX →

Bill Mark  
Bill Mark  
*Nombre y firma de las personas autorizadas*

Septiembre, 2000  
*Fecha*

**NOTA**

**GUARDE ESTAS INSTRUCCIONES. NO DESTRUYA.**

Una vez vencida la vida útil de herramienta, se recomienda desarmar la herramienta, desengrasarla y separar las piezas de acuerdo con el material del que están fabricadas para reciclarlas.

# INSTRUCTIES VOOR TYPE AW7500 ULTRA DUTY SLAGMOERSLEUTEL VOOR EXTRA ZWAAR WERK

## LET WEL

Type AW7500 Ultra Slagmoersleutel is ontworpen voor algemeen onderhoud van bussen, landbouwmachines, normale vrachtwagens en terreinvoertuigen.

Mac Tools is niet aansprakelijk voor door de klant aangebrachte veranderingen aan de gereedschappen voor toepassingen waarover met Mac Tools geen voorafgaand overleg werd gepleegd.

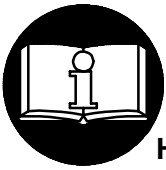

## ⚠ WAARSCHUWING

**BELANGRIJKE VEILIGHEIDSINFORMATIE IS INGESLOTEN.  
EERST DIT HANDBOEK LEZEN, DAN HET GEREEDSCHAP BEDIENEN.  
HET BEHOORT TOT DE VERANTWOORDELIJKHEID VAN DE WERKGEVER DE IN  
DIT HANDBOEK GEGEVEN INFORMATIE AAN DE GEBRUIKER TER HAND TE STELLEN.  
EEN NALATEN DE HIERNAVOLGENDE WAARSCHUWINGEN OP TE VOLGEN KAN  
LICHAMELIJK LETSEL TOT GEVOLG HEBBEN.**

### INGEBRUIKNEMING VAN HET GEREEDSCHAP

- Dit gereedschap altijd bedienen, controleren en onderhouden in overeenstemming met alle voorschriften (plaatselijk, staat, federaal en land), die betrekking hebben op hand-gehouden/hand-bediende pneumatische gereedschappen.
- Voor veiligheid, topprestatie, en maximale bestendigheid van de onderdelen dit gereedschap laten werken bij een maximale luchtdruk van 90 psig (6.2 bar/620 kPa) bij de inlaat met een luchttoevoerslang, die een inwendige diameter van 1/2" (13 mm) heeft.
- Men dient te allen tijde de luchtinlaat af te sluiten en de luchttoevoerslang te ontkoppelen voordat enig deel aan dit gereedschap wordt aangebracht, verwijderd of afgesteld, of voordat enig onderhoud aan dit gereedschap mag worden uitgevoerd.
- Geen beschadigde, gerafelde of versleten luchtslangen of fittingen gebruiken.
- Zorg ervoor dat alle slangen en fittingen de juiste afmetingen hebben en goed zijn vastgemaakt. Zie tekening TPD905-1 voor een typisch leidingnet.
- Altijd schone, droge lucht gebruiken bij een maximum luchtdruk van 90 psig. Stof, corroderende uitwasemingen en/of te grote vochtigheid kunnen de motor van een drukluchtgereedschap ruïneren.
- De gereedschappen niet smeren met ontvlambare of vluchtige vloeistoffen als petroleum, diesel of (straal) vliegtuigbrandstoffen.
- Geen typeplaatjes verwijderen. Beschadigde typeplaatjes moeten worden vervangen.
- U wordt aangeraden een slagklem te gebruiken. Een koppeling, die direct aan de luchtinlaat is aangebracht, doet de massa van het gereedschap toenemen en de beweeglijkheid van het gereedschap afnemen.
- Voor een topprestatie moet de koppeling een slag groter zijn dan de koppeling die bij het gereedschap wordt gebruikt. Een koppeling die zich het dichtst bij het gereedschap bevindt mag geen kleinere afmeting hebben dan de luchttoevoerslang.

### GEBRUIK VAN HET GEREEDSCHAP

- U moet te allen tijde oogbeschermers dragen wanneer u dit gereedschap bedient of er onderhoudswerkzaamheden aan uitvoert.
- Altijd oorbeschermers dragen wanneer dit gereedschap wordt bediend.
- Houd handen, losse kleding of lang haar weg van het draaiende eind van het gereedschap.
- Voordat het gereedschap in gebruik wordt genomen eerst op de stand van de omkeerknoppen of het omkeermechanisme letten, zodat u de draairichting kent wanneer de regelaar wordt gebruikt.
- Let op en anticipeer op plotselinge veranderingen in de werking van enig persluchtgereedschap zowel tijdens de start als gedurende het in bedrijf zijn.
- Steeds in een goede houding staan. Als u het gereedschap bedient mag u zich niet te ver uitstrekken. Hoge reactiekoppels kunnen voorkomen bij of beneden de aanbevolen luchtdruk.
- De as van het gereedschap kan even blijven draaien nadat de bediening is losgelaten.
- Persluchtgereedschappen kunnen tijdens gebruik ervan trillen. Trillingen, zich herhalende bewegingen, of ongemakkelijke houdingen kunnen schadelijk zijn voor uw handen en armen. Stop met bediening van enig gereedschap wanneer u ongemak, een tintelend gevoel of pijn ervaart. Zoek medisch advies alvorens het werk te hervatten.
- Uitsluitend de door Mac Tools aanbevolen bijbehorende hulpstukken gebruiken.
- Uitsluitend moerdoppen voor impactdoppen en bijbehorende hulpstukken gebruiken. Geen handmoersleutels (chrom) of bijbehorende hulpstukken gebruiken.
- Slagmoersleutels zijn geen momentsleutels. Aansluitingen die een specifiek koppel nodig hebben moeten, nadat zij met een slagmoersleutels zijn aangebracht, met een momentsleutel worden gecontroleerd.
- Dit gereedschap is niet ontworpen om er mee in explosieve omgevingen te werken.
- Dit gereedschap is niet geïsoleerd tegen elektrische schokken.

## LET WEL

Het gebruiken van andere dan originele Mac Tools onderdelen kan gevaar opleveren voor de veiligheid, en een vermindering met zich brengen van het prestatievermogen van het gereedschap en een toeneming van het onderhoud ervan; het kan een vervallen van alle garantie-bepalingen tot gevolg hebben.

Reparaties mogen uitsluitend worden uitgevoerd door hiertoe gemachtigd en geschoold personeel. Raadpleeg uw dichtstbijzijnde erkende Mac Tools Servicenter.

## LABELS MET WAARSCHUWINGSINSTRUCTIES

### ⚠ WAARSCHUWING

EEN NALATEN DE HIERNAVOLGENDE WAARSCHUWINGEN OP TE VOLGEN KAN LICHAAMELIJK LETSEL TOT GEVOLG HEBBEN.

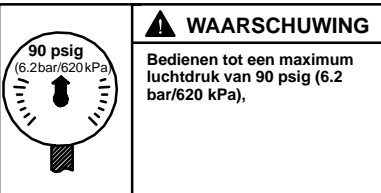
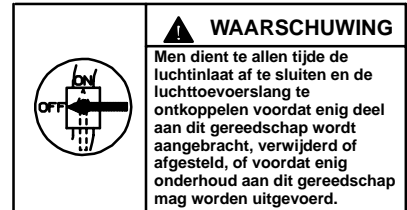

## GEBRUIK VAN HET VERMOGENBEHEERSSYSTEEM

### ⚠ WAARSCHUWING

Slagmoersleutels hebben geen koppelregeling. Bevestigingsbouten met specifieke koppelbehoeften moeten nadat ze met een slagmoersleutel zijn aangebracht worden gecheckt met de juiste momentsleutels.

De Type AW7500 bezitten een vermogenbeheerssysteem dat de monteur toestaat vier instellingen voor vermogensafgifte te selecteren. Deze instellingen hebben uitsluitend in voorwaartse richting een bereik van minimum vermogensafgifte tot maximum vermogensafgifte. De slagmoersleutel zal in de omgekeerde richting te allen tijde op maximum vermogensafgifte werken, onverschillig welke vermogensafgifte werd gekozen.

### TYPE AW7500 VERMOGENBEHEERSSYSTEEM

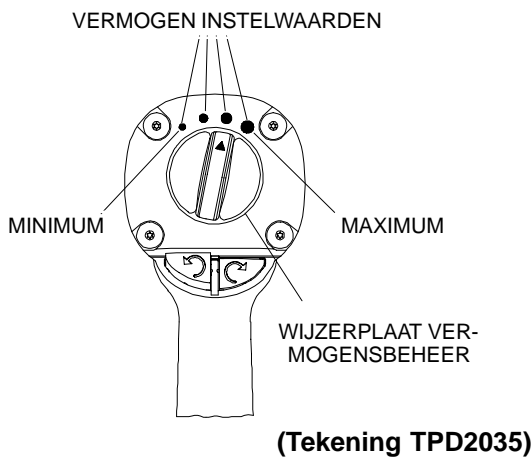

### ⚠ WAARSCHUWING

De vier indicators voor vermogensinstelling van toenemende grootte die op de achterkant van het huis zijn aangebracht en de toenemende niveaus voor vermogensafgifte weergeven, zijn uitsluitend bedoeld als referentie en geven GEEN specifieke vermogensafgifte weer. De kleinste instelling van de vermogensindicator geeft minimum vermogensafgifte aan, de twee middelste vermogensindicatoren geven middel vermogensafgifte aan en de grootste vermogeninstelindicator geeft de maximum vermogensafgifte aan.

De vermogensafgifte kan voorwaarts of achterwaarts nog verder worden gereduceerd met de bedieningsknop. Luchttoevoersystemen met onvoldoende luchtdruk kunnen invloed hebben op de vermogensafgifte.

# INGEBRUIKNEMING VAN HET GEREEDSCHAP

## DE SMERING



### Mac Tools Pneumatic



Gebruik **Mac Tools Pneumatic**, voor routine uitwendige smering van het slagmechanisme aan te brengen via de Smeernippel op het Hamerhuis.

Gebruik **Mac Tools Pneumatic** wanneer het slagmechanisme wordt gedemonteerd en gemonteerd.

Men moet bij deze gereedschappen steeds een in-lijn aangesloten drukluchtsmeerinrichting gebruiken.

Wij bevelen u de volgende Filter-Smeerinrichting-Regeleenheid aan:

Voor de USA – Nr. C18-03-FKG0-28  
Voor Internationaal – C18-C3-FKG0

## OPPASSEN

U mag geen enkel niet-metaal oppervlak van dit gereedschap merken met een identificatiecode van de klant. Dit kan de prestatie van het gereedschap beïnvloeden.

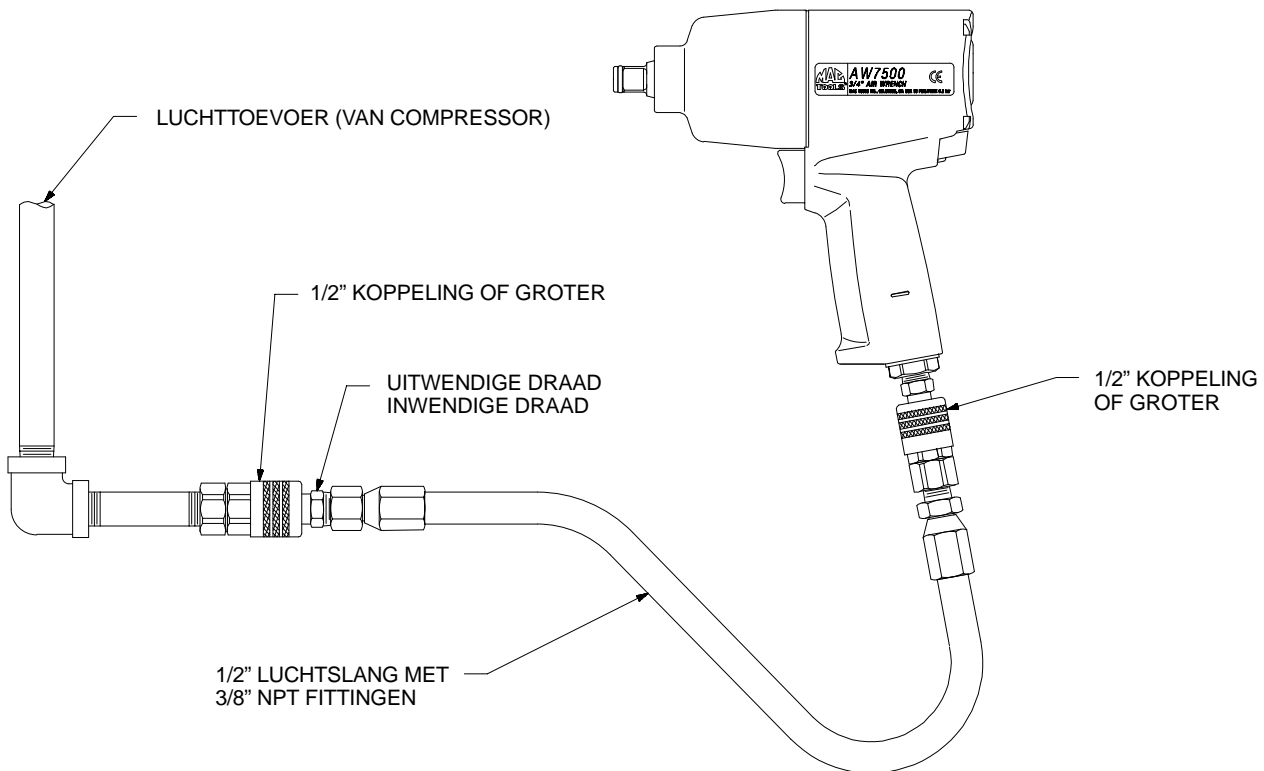
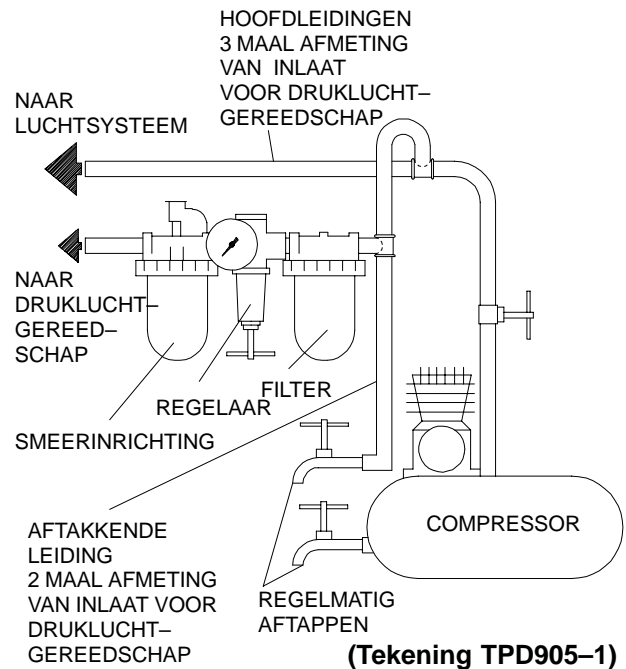

(Tekening 1814)

# INGEBRUIKNEMING VAN HET GEREEDSCHAP

## SPECIFICATIES

Type	Soort hendel	Aandrijving	Slagen/ min	Aanbevolen koppelbereik	
				Vooruit ft-lb (Nm)	Achteruit ft-lb (Nm)
AW7500	pistoolgreep	3/4"	1.175	200–900 [1100 Max] (271–1220 [1492 Max] )	200–900 [1200 Max] (271–1220 [1627 Max] )

Type	■ Geluidsniveau dB (A)		◆ Trillingsniveau
	Deuk	Vermogen	m/s <sup>2</sup>
AW7500	102,9	115,9	5,9

- Getest overeenkomstig PNEUROP PN8NTC1.2
- ◆ Getest volgens ISO8662–7 onder belasting van wrijvingsrem tot 9 TPM

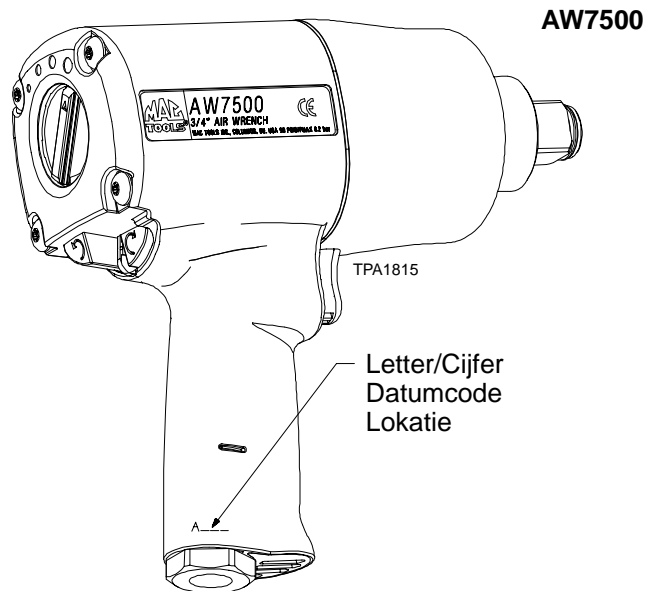

**SCHRIFTELIJKE VERKLARING VAN CONFORMITEIT**

**Wij** Mac Tools  
(naam leverancier)

Columbus, OHIO 43232 USA  
(adres)

verklaren, onder onze uitsluitende aansprakelijkheid, dat het produkt:

Type AW7500 Slagmoersleutel voor Extra Zwaar Werk (Ultra Duty)

waarop deze verklaring betrekking heeft overeenkomt met de bepalingen van directieven:

98/37/EG

overeenkomstig de volgende hoofdstandaards: ISO8662, PNEUROP PN8NTC1

Serienummers: (2000 →) A00H XXXXX →

Bill Mark  
Bill Mark  
Naam en handtekening van gemachtigde personen

September, 2000  
Datum

**LET WEL**

**DEZE INSTRUCTIES GOED BEWAREN. NIET VERNIETIGEN.**

Wanneer de levensduur van het gereedschap verstreken is, wordt u aangeraden het gereedschap te demonteren en ontvetten, en de delen gescheiden naar materialen op te bergen zodat zij gerecycled kunnen worden.

**MAINTENANCE INSTRUCTIONS**  
**SECTION D'ENTRETIEN**  
**WARTUNG**  
**SEZIONE DI MANUTENZIONE**  
**INSTRUCCIONES DE MANTENIMIENTO**  
**ONDERHOUD**

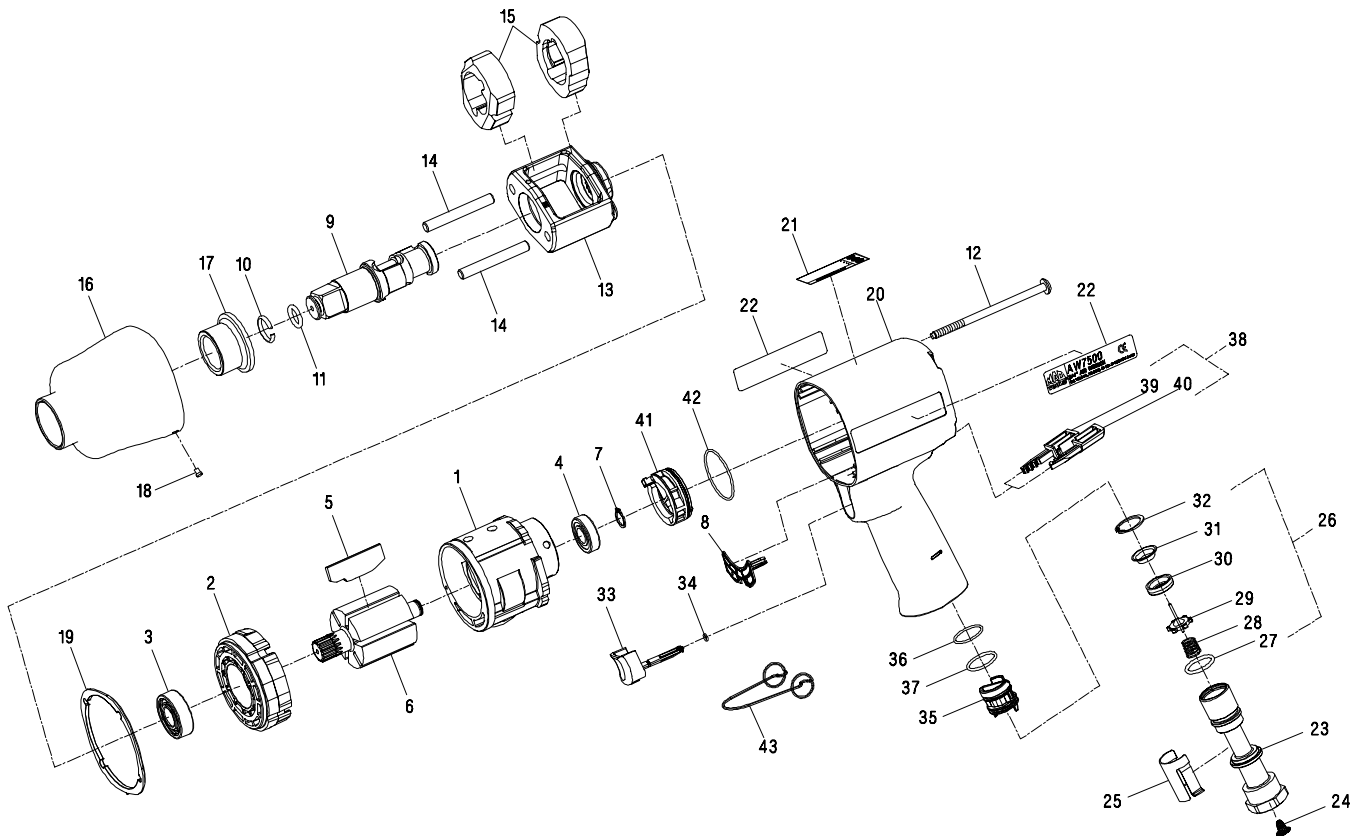

**(TPA1816)**

PART NUMBER FOR ORDERING  
 REFERENCE POUR COMMANDE DE LA PIECE  
 BESTELLNUMMER  
 NUMERO DEL PEZZO PER L'ORDINAZIONE  
 SIMBOLO DE LA PIEZA PARA PEDIDOS  
 BESTELNUMMERS

1	Cylinder	2141-3	26	Inlet Parts Kit	2141-K303
2	Front End Plate	2141-11	27	Inlet Bushing Seal	R4-210
3	Front Rotor Bearing	R38P-606	28	Tilt Valve Spring	2131-51
4	Rear Rotor Bearing	2131-97	29	Tilt Valve	2141-302
• 5	Vane Packet (set of 6 Vanes)	2141-42-6	30	Tilt Valve Seat	2141-303
6	Rotor	2141-53	31	Tilt Valve Seat Support	2141-306
7	Rear Rotor Bearing Retainer	2131-6	32	Tilt Valve Seat Retainter	SML8-24
• 8	Motor Gasket	2141-283	• 33	Trigger Assembly	2141-A93
9	Anvil Assembly	2141-A626	34	Trigger O-ring	_____
• 10	Socket Retainer	908B5-918	35	Reverse Valve Assembly	2141-A329
• 11	Socket Retainer O-ring	AF120-289	36	Reverse Valve O-ring (top)	_____
12	Hammer Case Screw (4)	2141-638	37	Reverse Valve O-ring (bottom) (blue)	_____
	Hammer Frame Assembly	2141-A703	38	Button Kit	AW7500-K75
13	Hammer Frame	2141-703	39	Forward Button	AW7500-75
14	Hammer Pin (2)	2141-704	40	Reverse Button	AW7500-76
15	Hammer (2)	2141-724	41	Power Management Dial	2131-A249
16	Hammer Case Assembly	2141-A727	42	Power Management Dial Seal	_____
17	Hammer Case Bushing	2141-641	43	Inlet Clip Removal Tool	2131-322
18	Grease Fitting	D0F9-879	*	Grease (1 lb) (for external lubrication of the impact mechanism)	115-1LB
• 19	Hammer Case Gasket	AW7500-36	*	Grease (for lubrication when disassembling and assembling the impact mechanism)	
20	Housing Assembly	AW7500-B40		1 lb	105-1LB
21	Warning Label	WARNING-2-99		8 lb	105-8LB
22	Nameplate (2)	AW7500-301	*	Grease Gun	R000A2-228
	Inlet Bushing Assembly	2141-D565			
23	Inlet Bushing	2141-565			
24	Inlet Bushing Screen	5RA-61			
25	Inlet Retainer Clip	2141-57			

\* Not illustrated.

- To keep downtime to a minimum, it is desirable to have on hand certain repair parts. We recommend that you stock one (pair or set) of each part indicated by a Bullet (•) for every four tools in service.

## MAINTENANCE SECTION

### DISASSEMBLY

#### General Instructions

1. Do not disassemble the tool any further than necessary to replace or repair damaged parts.
2. Whenever grasping a tool or part in a vise, always use leather-covered vise jaws to protect the surface of the part and help prevent distortion. This is particularly true of threaded members and housings.

#### NOTICE

Always use leather-covered vise jaws when clamping the handle in a vise. Leather will conform to the shape of the handle and allow the tool to be held securely. To prevent damage to the exhaust diffuser, never clamp only the bottom of the handle.

3. Do not remove any part which is a press fit in or on a subassembly unless the removal of that part is necessary for repairs or replacement.
4. Do not disassemble the tool unless you have a complete set of new gaskets and O-rings for replacement.

#### Disassembly of the Impact Wrench

1. Clamp the handle of the impact wrench in a vise with leather-covered jaws with the square drive positioned horizontally.

#### NOTICE

Avoid excessive clamping pressure which can damage the Housing and can cause difficulty when removing the parts.

2. Unscrew and remove the four Hammer Case Screws (12).
3. While lightly tapping on the end of the Anvil (9) with a plastic hammer, lift off the Hammer Case (16) and Hammer Case Gasket (19).

#### NOTICE

The Front End Plate (2) might come off during the removal of the Hammer Case. Make sure that it does not drop on the floor or strike a hard or metallic surface since it might be damaged.

4. Grasp the Hammer Frame (13) and carefully lift off the entire impact mechanism, making certain not to drop the two Hammer Pins (14).

#### Disassembly of the Impact Mechanism

1. Set the mechanism, driver end up, on the workbench.

#### NOTICE

Note the twin hammers within the Hammer Frame. These are identical, but must be placed in the Hammer Frame in a certain relationship. Using a felt-tipped pen, mark the top hammer “T↑” and the bottom hammer “B↑” with the arrows pointing upward. Mark both Hammers on the same end.

2. With the mechanism sitting upright on the workbench, slowly rotate the Anvil in a clockwise direction until it comes up solid.

#### NOTICE

If you continue to rotate the Anvil, it will cam the Hammers out of engagement. Don't do this; merely rotate the Anvil until it comes up solid.

3. Hold the Hammer Frame firmly and without disturbing the hammers, gently lift the Anvil while simultaneously rotating it clockwise about 1/8 of a turn, from the Hammer Frame.
4. With the Anvil removed, lift out the two Hammer Pins.

#### NOTICE

The twin hammers are now free to slide from the Hammer Frame. Be careful do not to drop them.

#### Disassembly of the Motor

#### NOTICE

When pulling, disassembling or assembling the motor, we recommend replacement of the Motor Gasket (8).

1. Remove the Motor Assembly from the Housing (20) by pushing on Power Management Dial (41) from the back of the Housing. See Dwg. TPD1322.

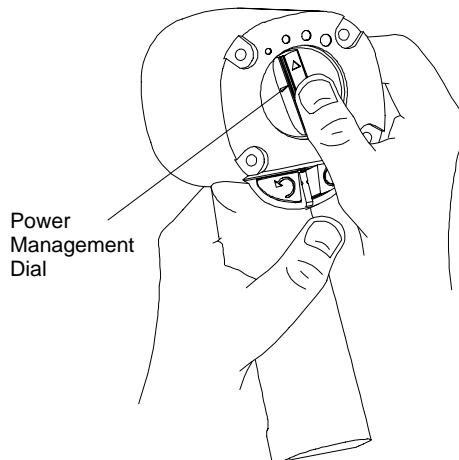

#### NOTICE

If the Motor Assembly cannot be removed from the Housing by pushing, tap the Power Management Dial lightly until the Motor Assembly is free.

2. Remove the Power Management Dial from the rear of the Cylinder (1). Remove the Power Management Dial Seal (42) if it needs to be replaced.
3. Remove the Front End Plate (2) from the Cylinder by tapping the splined end of the Rotor (6) with a plastic hammer. If the Front End Plate does not come loose, secure a center punch in a vise with the point angled downward and outward from the vise. Grasp the Cylinder and Front End Plate in one hand and position the hole in the end of the Rotor against the punch.

#### NOTICE

Be careful not to drop the Cylinder since it can be damaged by hitting a hard surface.

Using the other hand, tap the punch with a hammer while pressing the Rotor against the punch. After a few taps, the Front End Plate will slide off of the Cylinder.



## MAINTENANCE SECTION

### NOTICE

To prevent damage to the Cylinder, do not tap or strike Cylinder on a hard or metallic surface when removing the Rotor Bearings (3) and (4).

To remove the Front Rotor Bearing, hold the Front End Plate with Front Rotor Bearing down and tap the Front End Plate on a flat, nonmetallic surface such as a work bench. This will loosen the Front Rotor Bearing so that it will drop out of the Front End Plate. See Dwg. TPD1323.

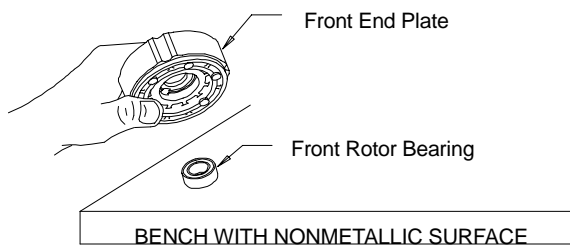

(Dwg. TPD1323)

4. Remove the Rear Rotor Bearing Retainer (7) from the rear of the Rotor (6). The Rotor can now be removed from the Cylinder. Remove the Vanes (5) from the Rotor if they need to be replaced.

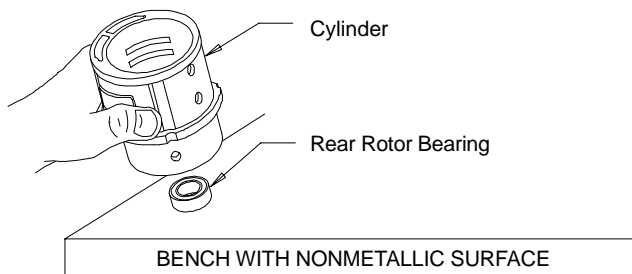

(Dwg. TPD1324)

5. To remove the Rear Rotor Bearing, hold the Cylinder with the Rear Rotor Bearing down and tap the Cylinder on a flat, nonmetallic surface such as a work bench. This will loosen the Rear Rotor Bearing so that it will drop out of the Cylinder. See Dwg. TPD1324.
6. Working from the rear of the Housing, push out the Motor Gasket (8).

### NOTICE

When removing the Motor Gasket, do not use a screwdriver or any other sharp object which could damage the Gasket and/or Housing.

### Disassembly of the Throttle Mechanism

### NOTICE

For ease of disassembly, we recommend using the Inlet Clip Removal Tool (43). See Dwg. TPD1817.

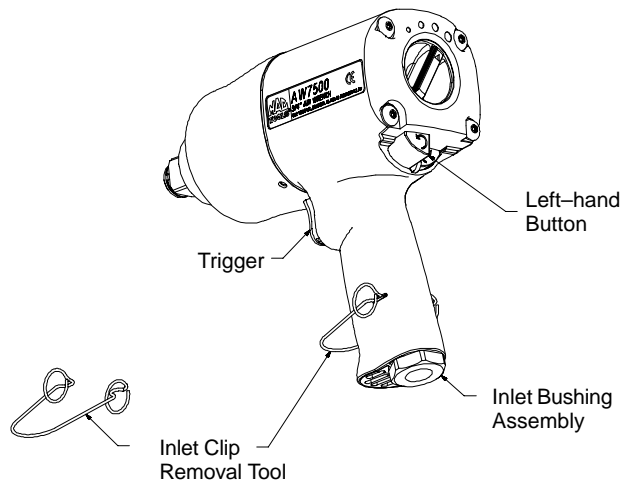

(Dwg. TPD1817)

1. Secure the Inlet Bushing in a vise. Press in both tabs of the Inlet Retainer Clip (25) and pull upward on the Housing (20). This will allow the Inlet Bushing to come free from the Handle of the Housing. See Dwg. TPD1326.
2. Pull the Trigger (33) from the front of the Housing and remove the Trigger O-ring (34).

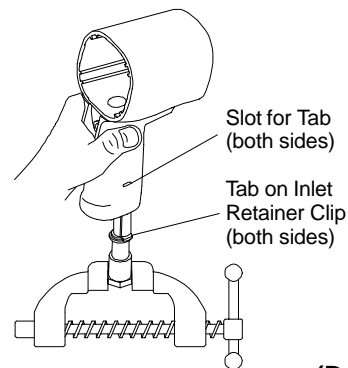

(Dwg. TPD1326)

3. With the Inlet Bushing still in the vise, remove the Tilt Valve Seat Retainer (32) and Tilt Valve Seat Support (31). Use a hooked tool with no sharp edges to remove the Tilt Valve Seat (30) from the Inlet Bushing. See Dwg. TPD1327.

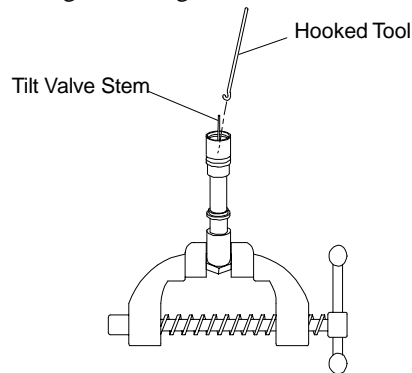

(Dwg. TPD1327)

4. Remove the Tilt Valve (29) and Tilt Valve Spring (28) if damaged.
5. Remove the Inlet Bushing Seal (27) and Inlet Retainer Clip (25) if damaged.

### NOTICE

Do not remove the Inlet Bushing Screen (24) from the Inlet Bushing unless it is damaged. Clean the Inlet Bushing Screen by using a suitable cleaning solution in a well ventilated area.

## MAINTENANCE SECTION

### Disassembly of the Reverse Valve Mechanism

#### NOTICE

The Reverse Valve Assembly cannot be removed without first removing the Forward and Reverse Buttons (39) and (40). Therefore, it is important that the procedure below be followed exactly.

1. Insert the screwdriver between the partition and the Button which is fully extended. Gently pry against the Button to disengage the detent so that the Button can be removed. After the Button is removed, reach inside the Housing and rotate the Reverse Valve to extend the remaining Button. Repeat the above procedure for the remaining Button. See Dwg. TPD1328.

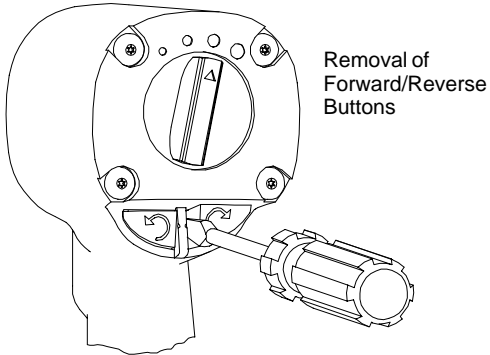

(Dwg. TPD1328)

2. Insert thumb into the front of the Housing and push **down** on the Reverse Valve so that it can be removed through the bottom of the handle. See Dwg. TPD1329.

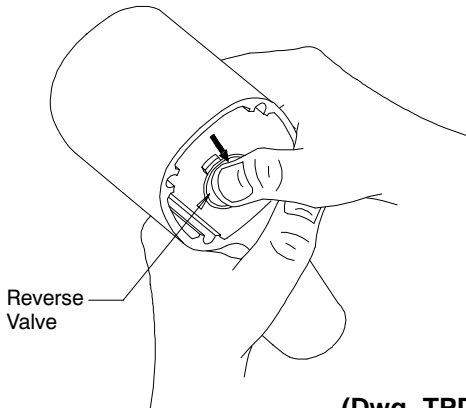

(Dwg. TPD1329)

#### NOTICE

Do not try to remove the Reverse Valve by pushing upward. It can only be removed by pushing it downward and out of the bottom of the handle. If the Reverse Valve does not come free, tap the bottom of the handle lightly with a rubber hammer until it drops out.

3. Remove the Top Reverse Valve O-ring (36) and the Bottom Reverse Valve O-ring (37) from the Reverse Valve.

### ASSEMBLY

#### General Instructions

1. Whenever grasping a tool or part in a vise, always use leather-covered vise jaws to protect the surface of the part and help prevent distortion. This is particularly true of threaded members and housings.

#### NOTICE

Always use leather-covered vise jaws when clamping the handle in a vise. Leather will conform to the shape of the handle and allow the tool to be held securely. To prevent damage to the exhaust diffuser, never clamp only the bottom of the handle.

2. Always clean every part and wipe every part with a thin film of oil before installation.

#### NOTICE

Do not remove grease from the impact mechanism or Hammer Case (16). If the impact mechanism has not been disassembled, inject Mac Tools Pneumatic Grease through the Hammer Case Grease Fitting (18).

When disassembling and assembling the impact mechanism, remove all grease from the impact mechanism and Hammer Case and lubricate the impact mechanism and Hammer Case Bushing (17) with Mac Tools Pneumatic Grease.

3. Apply a film of o-ring lubricant to all O-rings before final assembly.

### Assembly of the Reverse Valve Mechanism

1. Install the Bottom Reverse Valve O-ring (37) (color-coded blue) and the Top Reverse Valve o-ring (36) on the Reverse Valve (35).
2. Insert the Reverse Valve in the bottom of the handle making sure that two ears on the Reverse Valve are facing downward. See Dwg. TPD1330.

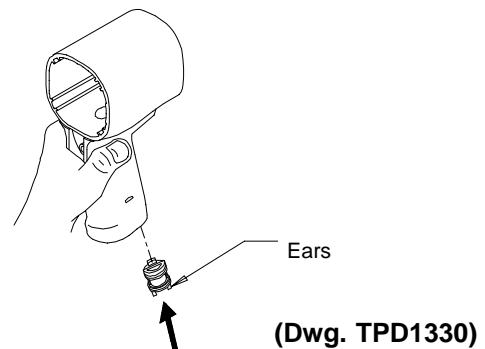

Use a wooden dowel to push the Reverse Valve up through the handle until the top of the Reverse Valve is flush with or slightly above the bottom of the motor bore in the Housing (20). See Dwg. TPD1331.

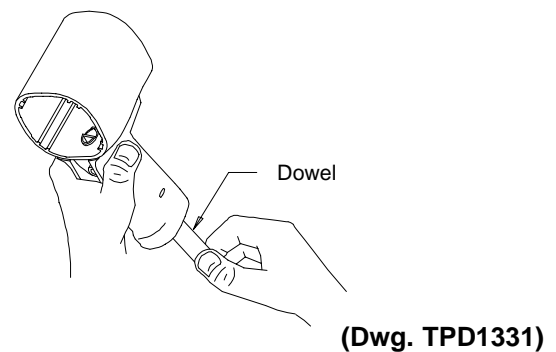

#### NOTICE

If the Reverse Valve is pushed up too far and becomes wedged, it will have to be pushed back down through the the handle and re-inserted from the bottom of the handle. The Reverse Valve cannot be removed by pushing it up through the handle and into the motor bore. If the Reverse Valve must be removed and re-installed, make sure that the Top and Bottom Reverse Valve O-rings have not been rolled off and are in their proper positions on the Reverse Valve.

## MAINTENANCE SECTION

- When the Reverse Valve has been installed, rotate the Reverse Valve so that the tab on the Reverse Valve is at the rear of the Housing. See Dwg. TPD1332.

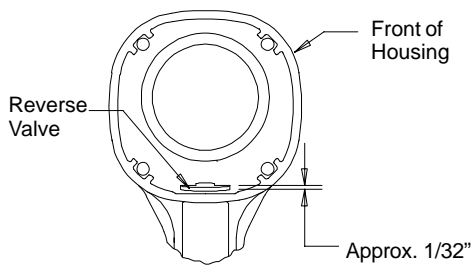

(Dwg. TPD1332)

### NOTICE

**If the orientation of the Reverse Valve is not correct (tab facing the rear of the Housing), the Trigger (33) and the Forward and Reverse Buttons (39) and (40) cannot be installed.**

- Install the Trigger O-ring (34) on the Trigger. Insert the Trigger Assembly in the front of the Housing.
- Rotate the Reverse Valve in either direction until an ear comes up against the Trigger.
- Look through the Housing from the **rear**. If the tab on the Reverse Valve has been rotated to the **left**, install the **right** Button in the Housing. When one Button has been installed, push the Button in. This will rotate the Reverse Valve so that the other Button can be installed. See Dwg. TPD1333.

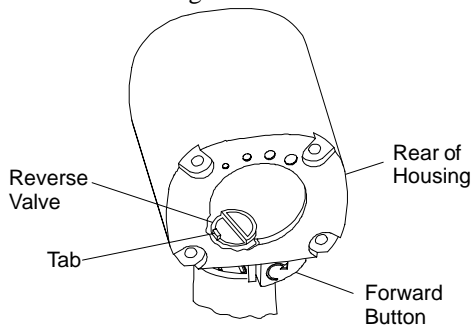

(Dwg. TPD1333)

**If the tab on the reverse Valve has been rotated to the right, install the left Button. See Dwg. TPD1334.**

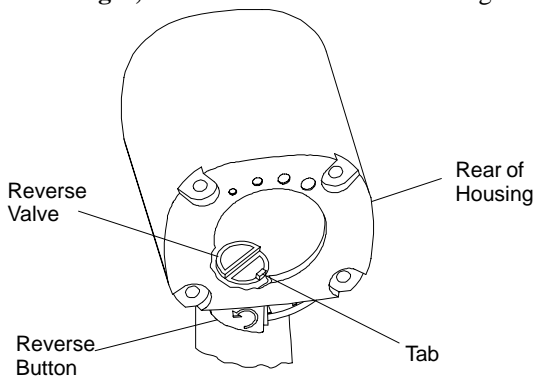

(Dwg. TPD1334)

### NOTICE

**If the Forward/Reverse Buttons will not install easily, move the Reverse Valve slightly higher in the handle to provide better alignment with the Buttons.**

- After the Forward/Reverse Buttons have been installed, remove the Trigger before proceeding with installation of the throttle mechanism.

### Assembly of Throttle Mechanism

- Using an Inlet Bushing Screen Installation Tool, install the Inlet Bushing Screen (24), screened end first, in the bottom (hex end) of the Inlet Bushing (23). Insert the rounded end of the tool in the cone formed by the screen and tap the end of the tool to secure the rim of the screen in the Bushing. See Dwg. TPD1473.

#### Inlet Bushing Screen Installation Tool

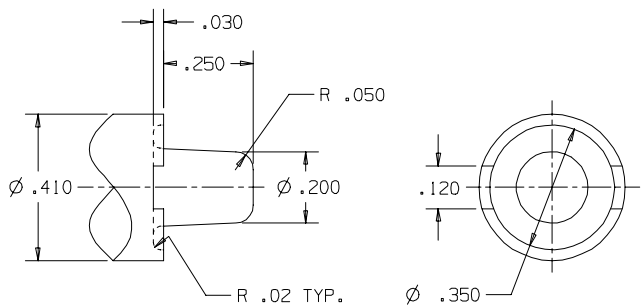

(Dwg. TPD1473)

- Install the Inlet Retainer Clip (25), Inlet Bushing Seal (27), Tilt Valve Spring (28), Tilt Valve (29), Tilt Valve Seat (30) and Tilt Valve Seat Support (31).

### ⚠ WARNING

**The Tilt Valve Seat Retainer (32) must be properly installed in the groove in the Inlet Bushing (23). To check for correct installation of the Retainer, insert a pin into one of the holes in the Retainer and rotate the Retainer. A correctly installed Retainer will rotate freely but with some resistance in the groove of the Inlet Bushing. An incorrectly installed Retainer will pop out of the Inlet Bushing when the Retainer is rotated.**

### ⚠ WARNING

**Do not use compressed air to check installation of the Tilt Valve Seat Retainer or Inlet Bushing Screen unless the entire Inlet Bushing Assembly is installed in the tool with the Hammer Case installed and properly secured to the Motor Housing. Failure to do so could result in injury. Install the Tilt Valve Seat Retainer.**

### NOTICE

**When re-installing the Inlet Bushing Assembly, pull the Trigger (33) outward and make sure that the Reverse Button (40) is depressed before snapping the Inlet Bushing Assembly back into the Housing.**

- Install the Inlet Bushing Assembly by pushing it into the hole in the Housing until you see and hear the tabs on Inlet Retainer Clip snap into place through the slots in Housing handle.

## MAINTENANCE SECTION

### NOTICE

**The Reverse Button (left) (40) must be pushed in before the Trigger can be installed. Otherwise, the Trigger will be damaged during installation.**

4. Install the Trigger by pushing it into the handle until a click is heard indicating that it is properly engaged.

### Assembly of the Motor

### NOTICE

**When disassembling, assembling or pulling the Motor, we recommend replacement of the Motor Gasket (8).**

1. Install the Motor Gasket in the Housing making sure that the grooves in the tab of the Motor Gasket fit around ridge in the Housing. See Dwg. TPD1336.

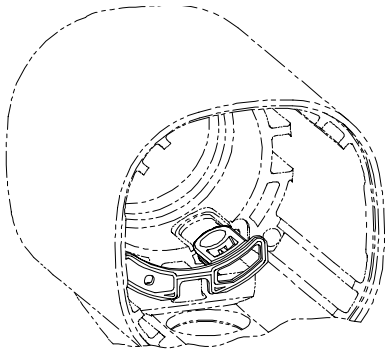

Installation  
of Motor  
Gasket

(Dwg. TPD1336)

2. Install the Rear Rotor Bearing (4) into the rear of the Cylinder (1).
3. Install the Rotor in the Cylinder and secure with the Rear Rotor Bearing Retainer (7).
4. Install Vanes (5) in the slots in the Rotor (6).
5. Install the Front Rotor Bearing (3) into the Front End Plate (2). Install the Front End Plate on the Cylinder by pressing on the inner race of the front Rotor Bearing until the Bearing is seated on the Rotor Shaft.
6. Install the Power Management Dial Seal (42) on the Power Management Dial (41), and install the Dial in the end of the Cylinder.
7. Insert the Motor Assembly into the Housing (20), Power Management Dial end first.

### Assembly of the Impact Mechanism

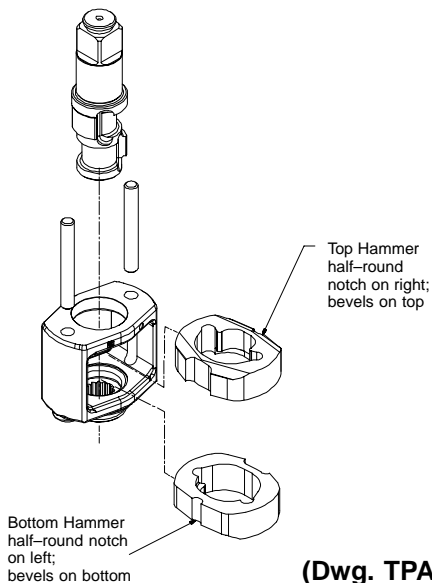

(Dwg. TPA1813)

1. Coat the Hammers (15) with a light film of Mac Tools Pneumatic Grease.
2. Heavily coat the jaws of the Anvil (9) with Mac Tools Pneumatic Grease.
3. Replace the Hammers in the Hammer Frame (13) exactly as they were when you marked them prior to disassembly.
4. Replace the Hammer Pins (14).
5. Examine the base of the Anvil (9) and note its contour. While looking down through the Hammer Frame, swing the top Hammer to its full extreme one way or another until you can match the contour of the Anvil. Enter the Anvil into the Hammer Frame and through the first Hammer. Swing the bottom Hammer in the opposite direction from the top Hammer and maneuver the Anvil slightly until it drops into the bottom Hammer. See Dwg. TPD1813.

### NOTICE

**Be sure to position the Top Hammer with the half-round notch on the right and the bevels on the top, and the Bottom Hammer with the half-round notch on the left and the bevels on the bottom, as shown in Dwg. TPA1813.**

### Assembly of the Air Wrench

1. Position the Motor Housing (20) in leather-covered vise jaws with the splined shaft of the Rotor in a horizontal position.
2. Place the assembled impact mechanism down onto the splined hub of the Rotor.
3. Position the Hammer Case Gasket (19) against the face of the Motor Housing.

### NOTICE

**Be sure that the small tab on outside surface of the Gasket is located in line with the center of the Trigger.**

See Dwg. TPA1811.

4. Apply a thin film of Mac Tools Pneumatic Grease on inside surface of the Hammer Case Bushing (17), and place the Hammer Case (16) down over the Anvil and against the Motor Housing.

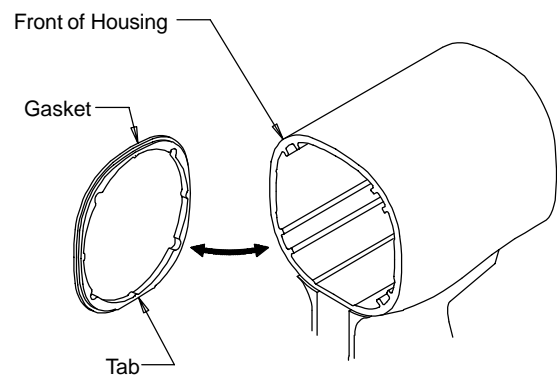

(Dwg. TPA1811)

5. Install the Hammer Case Screws (12) and tighten them to 15 in-lb (1.7 Nm) torque.

## MAINTENANCE SECTION

### TROUBLESHOOTING GUIDE

Trouble	Probable Cause	Solution
Low power	Dry Motor	<b>Daily</b> , inject 3 cc of Mac Tools Pneumatic Oil into the inlet and run the tool to lubricate the motor.
	Inadequate air supply	Install proper air supply and connection. Refer to Dwg. TPD905-1 and Dwg. TPA1814 on Page 3.
	Dirty Inlet bushing Screen	Using a clean, suitable, cleaning solution in a well ventilated area, clean the Inlet Bushing Screen.
	Worn or broken Vanes	Replace a <b>complete</b> set of Vanes
	Worn or broken Cylinder and/or scored End Plates	Examine Cylinder. Check outside and ends for wear or damage and inside for scored or wavy bore. Replace Cylinder if any of these conditions exist. Replace End Plates if they are scored.
	Dirty motor parts.	Disassemble the Tool and clean in a clean, suitable, cleaning solution in a well ventilated area. Assemble the Tool and inject 3 cc of the recommended oil into Inlet and run Tool to lubricate internal parts.
Motor will not run	Damaged Reverse Valve	Replace Reverse Valve. Refer to <b>Installation of Reverse Valve.</b>
	Incorrect assembly of motor	Disassemble motor and replace worn or broken parts and reassemble. Refer to <b>Assembly of the Motor.</b>
Tool will not impact	Insufficient lubricant in impact mechanism.	Lubricate impact mechanism through Hammer Case Grease Fitting using the recommended grease.
	Broken or worn impact mechanism parts	Remove Hammer Case Assembly and examine impact mechanism parts. Replace any worn or broken parts.
	Impact mechanism not assembled correctly.	Refer to <b>Assembly of Impact Mechanism.</b>

### NOTICE

**SAVE THESE INSTRUCTIONS. DO NOT DESTROY.**

## VEJLEDNING TIL ULTRAKRAFTIGE SLAGNØGLER TIL AUTOBRANCHEN, MODEL AW7500

### BEMÆRK

Ultrakraftrige slagnøgler model AW7500 er designet til generel vedligeholdelse af busser, landbrugsmaskineri og lastbiler, inklusive terrængående modeller.

Mac Tools påtager sig intet ansvar for eventuelle ændringer af værktøjer udført af brugeren i forbindelse med anvendelsesområder, som Mac Tools ikke på forhånd er blevet konsulteret om.

### ⚠ ADVARSEL!

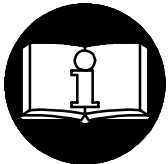

**INDEHOLDER VIGTIG SIKKERHEDSINFORMATION.  
DENNE VEJLEDNING SKAL LÆSES FØR BETJENING AF VÆRKTØJET.  
DET ER ARBEJDSGIVERENS ANSVAR AT SØRGE FOR, AT INDHOLDET  
AF DENNE VEJLEDNING BRINGES TIL OPERATØRENS KUNDSKAB.**

**MANGLENDE IAGTTAGELSE AF DISSE ADVARSLER KAN RESULTERE I PERSONSKADE.**

#### IBRUGTAGNING AF VÆRKTØJET

- Dette værktøj skal altid betjenes, kontrolleres og vedligeholdes i overensstemmelse med de gældende lokale og nationale regler for manuelle trykluftværktøjer.
- Af sikkerhedshensyn og for at opnå den bedst mulige ydelse og levetid for værktøjskomponenterne, skal værktøjet bruges ved et maksimalt indgangslufttryk på 6,2 bar og med en lufttilførselsslange, der har en indvendig diameter på 13 mm.
- Der skal altid lukkes for lufttilførslen, og lufttilførselsslangen skal afmonteres før installation, afmontering eller justering af tilbehør til dette værktøj, eller før der udføres vedligeholdelsesarbejde på værktøjet.
- Der må ikke bruges beskadigede, flossede eller nedslidte luftslanger og tilbehør.
- Det skal sikres, at alle slanger og alt tilbehør er af den korrekte størrelse og er sikkert monteret. Se tegning TPD905-1, som viser en typisk rørføring.
- Der skal altid bruges ren, tør luft ved et maksimalt lufttryk på 6,2 bar. Støv, korroderende dampe og/eller for høj fugtighed kan ødelægge motoren i et trykluftværktøj.
- Værktøjer må ikke smøres med brændbare eller flygtige væsker så som petroleum, dieselolie eller flybrændstof.
- Mærkater må ikke fjernes. Eventuelt beskadigede mærkater skal udskiftes.
- Det anbefales af bruge en slangeafstiver. Montering af kobling direkte på lufttilslutningen gør værktøjet tungere og mindre håndterligt.
- Dette værktøj skal altid bruges med en lufttilførselsslange, der har en indvendig diameter på 10 mm. For at opnå den bedst mulige værktøjsydelse, skal koblingen på væggen være én størrelse større end koblingen på værktøjet. Koblingen tættest på værktøjet bør ikke være mindre end den korrekte luftslanges størrelse.

#### ANVENDELSE AF VÆRKTØJET

- Der skal altid bruges beskyttelsesbriller under betjening eller vedligeholdelse af dette værktøj.
- Der skal altid bruges høreværn under betjening af dette værktøj.
- Hænder, løstsiddende tøj og langt hår skal holdes borte fra den roterende ende af værktøjet.
- Omskifterknappens eller -mekanismens placering skal altid noteres før betjening af værktøjet, så man ved hvilken retning værktøjet roterer i, når det startes.
- Under opstart og betjening af trykluftværktøjer, skal man forsøge at forudse og være særdeles opmærksom over for pludselige bevægelsesændringer.
- Der skal hele tiden holdes en kroppsstilling med god balance og godt fodgreb. Som operatør skal man undgå at strække sig for langt under brug af dette værktøj. Der kan forekomme voldsomme reaktionsmomenter ved eller under det anbefalede lufttryk.
- Værktøjets aksel kan fortsætte med at rotere et kort stykke tid, efter man har sluppet håndtaget.
- Trykluftværktøjer kan vibrere under brug. Vibration, hyppigt gentagne bevægelser og ubekvemme stillinger kan være skadelige for operatørens hænder og arme. Brug af værktøjet bør ophøre, hvis man føler nogen form for gener, en snurrende fornemmelse i kroppen eller smerter. Der skal søges lægehjælp, før brug af værktøjet genoptages.
- Der må kun bruges tilbehør, som anbefales af Mac Tools.
- Der må kun bruges krafttoppe og tilbehør. Der må ikke bruges (krom)toppe eller tilbehør til manuel betjening.
- En slagnøgle er ikke en momentnøgle. Tilspændinger, der kræver et bestemt moment, skal efter montering med en slagnøgle kontrolleres ved hjælp af en momentmåler.
- Dette værktøj er ikke designet til brug i eksplosive arbejdsmiljøer.
- Dette værktøj er ikke isoleret mod elektriske stød.

### BEMÆRK

Brug af reservedele, som ikke er originale Mac Tools produkter, kan resultere i sikkerhedsrisici, forringet værktøjsydelse samt ekstra vedligeholdelse, og kan gøre alle garantier ugyldige.

Reparationsarbejde må kun udføres af autoriseret og korrekt uddannet personale. Kontakt venligst det nærmeste autoriserede Mac Tools servicecenter.

# ADVARSELSMÆRKATER

## ⚠ ADVARSEL!

MANGLENDE IAGTTAGELSE AF DISSE ADVARSLER KAN RESULTERE I PERSONSKADE.

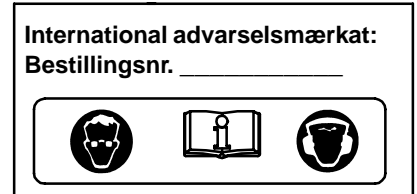
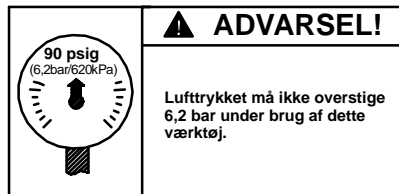
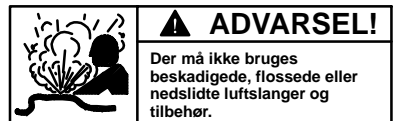
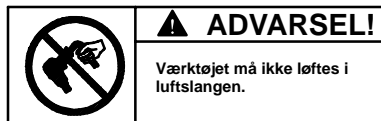
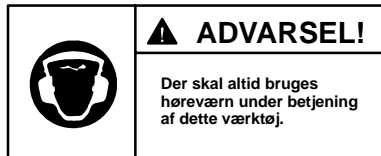

## SÅDAN BRUGES LUFTRYKKONTROLSYSTEMET

### ⚠ ADVARSEL!

En trykluftskruenøgle er ikke et momentværktøj. Bolte og møtrikker, der kræver et bestemt fastspændingsmoment, skal kontrolleres med en passende momentmåler efter fastspænding med en trykluftskruenøgle.

Slagnøgler af model AW7500 har et indbygget kontrolsystem, der sætter brugeren i stand til at vælge mellem fire trykluftindstillinger. Disse indstillinger varierer fra det lavest mulige luftryk til det højst mulige luftryk, dog kun i forbindelse med fastspænding. Slagnøglen vil altid arbejde med maksimalt luftryk ved løsning af bolte og møtrikker, uanset hvilket luftrykniveau der er valgt.

### ⚠ ADVARSEL!

### LUFTRYKKONTROLSYSTEM MODEL AW7500

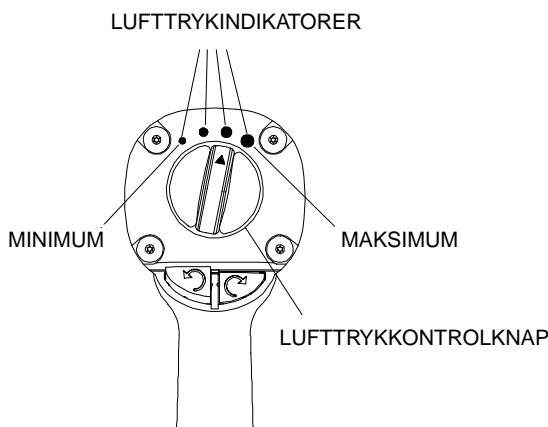

(Tegn. TPD2035)

De fire luftrykindikatorer i stigende størrelse på bagsiden af værktøjshuset angiver stigende luftryk og er kun til vejledning. De angiver IKKE et bestemt luftryk. Den mindste luftrykindikator angiver det lavest mulige luftryk, de to midterste indikatorer angiver middelhøjt luftryk, og den største indikator angiver maksimalt luftryk. Luftrykket kan reduceres yderligere ved fastspænding eller løsning ved hjælp af aftrækkeren. Trykluftsystemer med utilstrækkeligt tryk i luftforsyningen kan påvirke alle indstillingerne.

# IBRUGTAGNING AF VÆRKTØJET

## SMØRING



### Mac Tools Pneumatic



Mac Tools Pneumatic bør bruges til rutinemæssig smøring af hammermekanismen via smøreanordningen i hammerhuset.

Mac Tools Pneumatic bør bruges i forbindelse med demontering og genmontering af hammermekanismen.

Der skal altid bruges luftledningssmøring til disse værktøjer.

Vi anbefaler følgende filter-, smøreanordnings- og reguleringsenhed:

I USA – nr. C18-03-FKG0-28

Internationalt – nr. C18-C3-FKG0

## FORSIGTIG

Der må ikke sættes kundeidentifikationsmærker på de af værktøjets overflader, der ikke er af metal. Dette kan forringe værktøjets levetid.

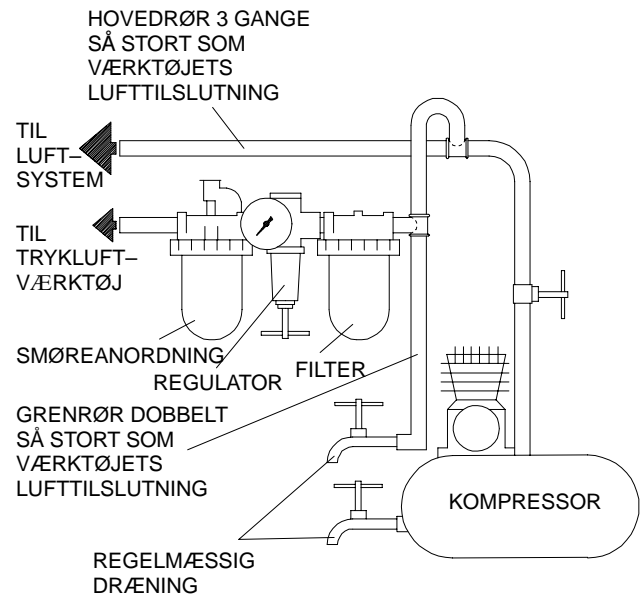

(Tegning TPD905-1)

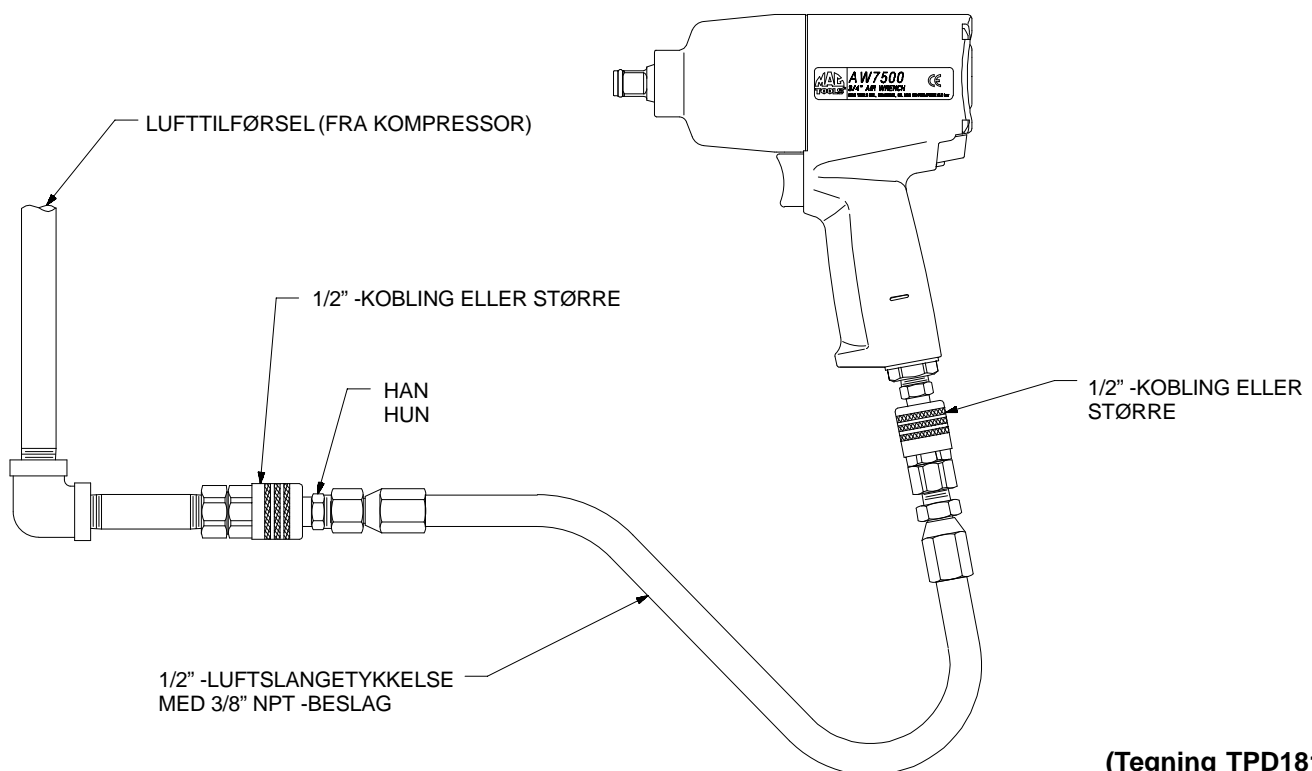

(Tegning TPD1814)



# IBRUGTAGNING AF VÆRKTØJET

## SPECIFIKATIONER

Model	Håndtags-type	Firkant	Slag/min.	Anbefalet momentområde	
				Frem ft-lb (Nm)	Bak ft-lb (Nm)
AW7500	pistolgreb	3/4"	1.175	200-900 [1100 maks] (271-1220 [1492 maks] )	200-900 [1200 maks] (271-1220 [1627 maks] )

Model	■ Lydniveau dB (A)		◆ Vibrations- niveau
	Tryk	Effekt	m/s <sup>2</sup>
AW7500	102,9	115,9	5,9

- Afprøvet i overensstemmelse med PNEUROP PN8NTC1.2
- ◆ Afprøvet i overensstemmelse med ISO8662-7, belastet med friktionsbremse til 9 o./min.

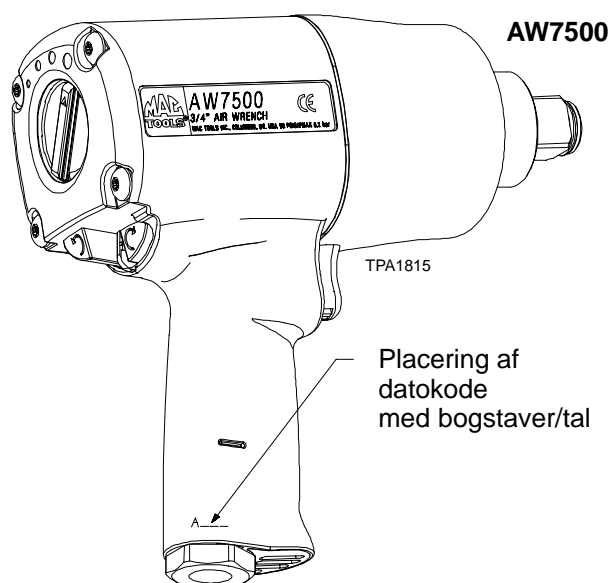

## FABRIKATIONSERKLÆRING

Vi Mac Tools  
(leverandørens navn)

Columbus, OHIO 43232 USA

(adresse)

erklærer som eneansvarlig, at nedenstående produkt,

Ultrakraftige slagnøgler til autobranschen, model AW7500

som denne erklæring vedrører, overholder bestemmelserne i følgende direktiver;

98/37/EF

ved at være i overensstemmelse med følgende hovedstandard(er):

ISO8662, PNEUROP PN8NTC1

Serienr. (2000 →) A00H XXXXX →

Bill Mark

Bill Mark  
Ansvarliges navn og underskrift

September, 2000

Dato

### BEMÆRK

**DENNE VEJLEDNING BØR GEMMES. MÅ IKKE DESTRUIERES.**

Efter værktøjets levetid anbefales det at demontere og affedte værktøjet, og opdele de adskilte komponenter ud fra materialetypen, så de kan genbruges.

## INSTRUKTIONER FÖR MUTTEREDRAGARE MED SLAGMEKANISM, MODELL, AW7500 FÖR TUNGA FORDON

**OBS!**

Modell AW7500 mutterdragare med slagmekanism är konstruerade för underhåll av bussar, jordbruksredskap och lastfordon.

Mac Tools är inte ansvarigt för verktyg som har modifierats av kunden för att anpassas till andra användningar, om inte kunden har konsulterat Mac Tools.

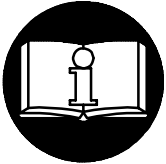
**⚠ VARNING**

**VIKTIG SÄKERHETSINFORMATION MEDFÖLJER.  
LÄS DENNA HANDBOK INNAN VERKTYGET ANVÄNDS.**

**DET ÅLIGGER ARBETSGIVAREN ATT SE TILL ATT DE ANSTÄLLDA SOM SKALL  
ANVÄNDA VERKTYGEN ÄR FÖRTROGNA MED HANDBOKENS INNEHÅLL.**

**UNDERLÅTELSE ATT IAKTTAGA FÖLJANDE VARNINGAR KAN MEDFÖRA PERSONSKADA.  
INNAN VERKTYGET ANVÄNDS**

- Användning, inspektion och underhåll av verktyget skall alltid ske i enlighet med på användningsplatsen rådande myndigheters gällande regler för handhållna mutterdragare.
- För säkerhet, bästa effektivitet och maximal livslängd bör detta verktyg användas med ett maximalt lufttryck på 6,2 bar/620 kPa (90 psi) vid intaget och med en matarslang med en innerdiameter på 13 mm (1/2 tum).
- Stäng alltid av lufttillförseln och koppla bort matarslangen innan du monterar, avlägsnar eller justerar några tillbehör till detta verktyg och innan du utför service på verktyget.
- Använd aldrig skadade, slitna eller trasiga luftslangar och kopplingar.
- Se till att alla slangar och kopplingar är av rätt storlek och ordentligt fastsatta. Se bild TPD905-1 för en typisk installation.
- Använd alltid ren, torr luft och ett maximalt lufttryck på 6,2 bar (90 psi). Damm, frätande ångor och/eller för hög fuktighet kan förstöra motorn på en mutterdragare.
- Smörj aldrig verktygen med lättantändliga eller flyktiga vätskor, som t.ex. fotogen, diesel- eller flygbränsle.
- Avlägsna ej etiketterna. Byt ut skadade etiketter.
- Användning av slangsockel rekommenderas. Om kopplingen ansluts direkt till luftslangen ökar verktygets vikt och dess manöverbarhet minskar.
- Använd alltid verktyget med 10 mm (3/8") luftslang. För maximal prestanda ska kopplingen på väggen vara en dimension större än på verktyget. Den koppling som sitter närmast verktyget bör inte ha mindre dimension än den angivna dimensionen på luftslangen.

**VERKTYGETS ANVÄNDNING**

- Använd alltid skyddsglasögon när du använder eller utför service på detta verktyg.
- Använd alltid hörselskydd när du använder detta verktyg.
- Håll händer, lösa kläder och långt hår på avstånd från den roterande verktygsdelen.
- Lägg märke till vilken inställning reverseringsknapparna eller mekanismen har innan verktyget startas, så att du vet åt vilket håll verktyget roterar när du öppnar ventilen.
- Förutse och var uppmärksam på plötsliga rörelseförändringar vid start och drift av alla motordrivna verktyg.
- Stå stadigt, med god balans. Sträck dig inte för långt över verktyget när du arbetar. Höga reaktionsvridmoment kan inträffa vid det rekommenderade lufttrycket.
- Verktyget kan fortsätta rotera en liten stund efter att du har stängt ventilen.
- Tryckluftsdrivna verktyg kan vibrera under användningen. Vibrationer, monotona rörelser eller en obekvämlig ställning kan vara skadligt för händer och armar. Upphör att använda ett verktyg om det börjar sticka eller värka i händer och armar. Sök läkare innan du åter använder verktyget.
- Använd sådana tillbehör som rekommenderats av Mac Tools.
- Använd endast krafthylsor och -tillbehör. Använd inte handverktygshylsor eller -tillbehör (förkromade).
- Slagverktyg är inga momentverktyg. Förbindningar som ska dras till angivna moment måste kontrolleras med en momentmätare efter åtdragning med slagverktyg.
- Detta verktyg är ej avsett att användas i explosiv atmosfär.
- Detta verktyg är ej isolerat mot elektrisk chock.

**OBS!**

Om andra reservdelar än de från Mac Tools används, kan detta medföra en säkerhetsrisk, minskad verktygsprestanda och ett ökat servicebehov. Det kan dessutom få till följd att alla garantier blir ogiltiga.

Reparationer får endast utföras av legitimerad, utbildad personal. Rådfråga närmaste legitimerade Mac Tools servicecenter.

## IDENTIFIERING AV VARNINGSETIKETTER

### ⚠ VARNING

UNDERLÅTELSE ATT IAKTTAGA FÖLJANDE VARNINGAR KAN MEDFÖRA PERSONSKADA.

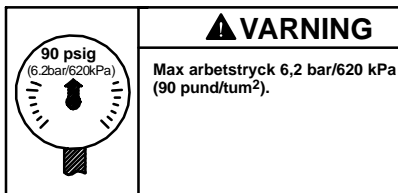
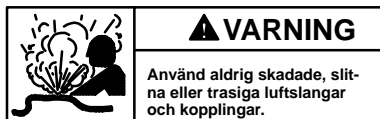
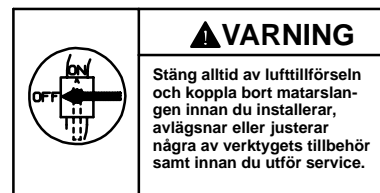
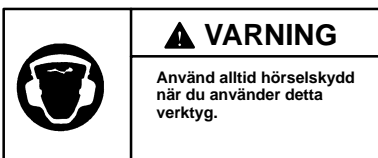
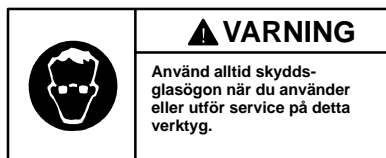

## ANVÄNDA MOMENTINSTÄLLNINGEN

### ⚠ VARNING

Luftdrivna skruvdragare är inte försedda med momentstyrning. Fästelement med speciella krav på åtdragningsmoment måste kontrolleras med lämplig momentmättningsutrustning sedan de har dragits åt med luftdrivna skruvdragare.

Skruvdragare modell AW7500 med hammarmekanism är försedda med ett momentinställningssystem som gör att operatören kan ställa in fyra olika utmoment. Inställningarna sträcker sig från minimi- till maximimoment för åtdragning. Luftdrivna skruvdragare arbetar alltid vid maximalt moment för lossdragning, oberoende av momentinställningen för åtdragning.

### MODELL AW7500 MOMENTINSTÄLLNINGSSYSTEM INDIKATORER FÖR MOMENTINSTÄLLNING

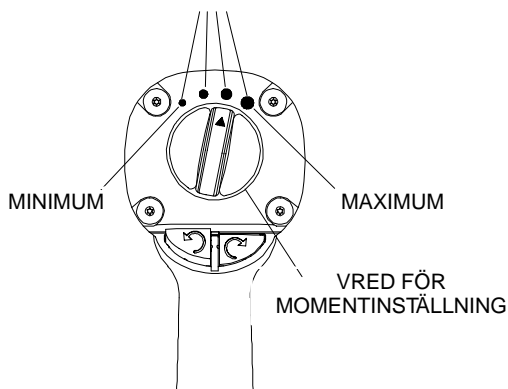

(Bild. TPD2035)

### ⚠ VARNING

De fyra momentinställningsindikatorerna som anger ökande utmoment på hammarhusets baksida är endast referensvärden och anger INTE något specifikt moment. Minimiinställningen anger det lägsta utmomentet, de två mellersta inställningarna anger mellanhöga moment och den högsta inställningen maximalt utmoment. Utmomentet kan minskas ytterligare i både fram- och backriktningen med hjälp av den ställbara ventilen. Tryckluftssystem med otillräckligt matningstryck kan påverka alla momentinställningar.

# INNAN VERKTYGET ANVÄNDS

## SMÖRJNING



### Mac Tools Pneumatic



Använd Mac Tools Pneumatic för daglig smörjning av slagmekanismen via smörjnippeln på hammarhuset.

Använd Mac Tools Pneumatic vid demontering och montering av slagmekanismen.

Använd alltid tryckluftssmörjare med dessa verktyg. Vi rekommenderar följande enhet som filtersmörjarregulator:

I USA: nr. C18-03-FKG0-28  
Internationellt: nr. C18-C3-FKG0

**OBS!**

Inga av detta verktygs icke-metalliska ytor får märkas med kundens identifieringskod. Detta kan medföra att verktygets funktion påverkas.

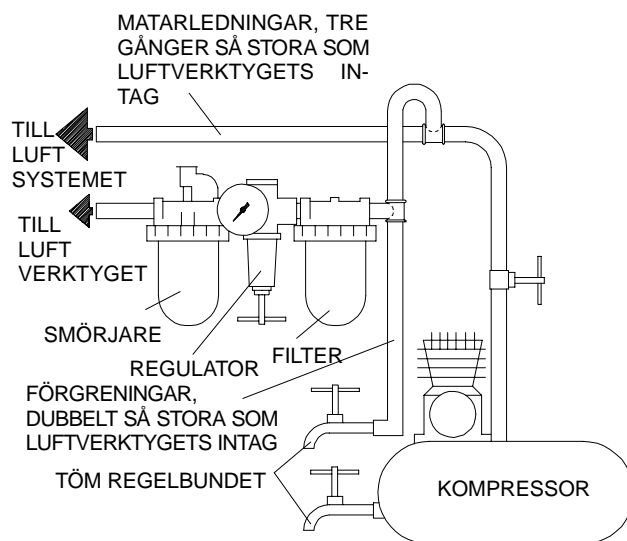

(Bild. TPD905-1)

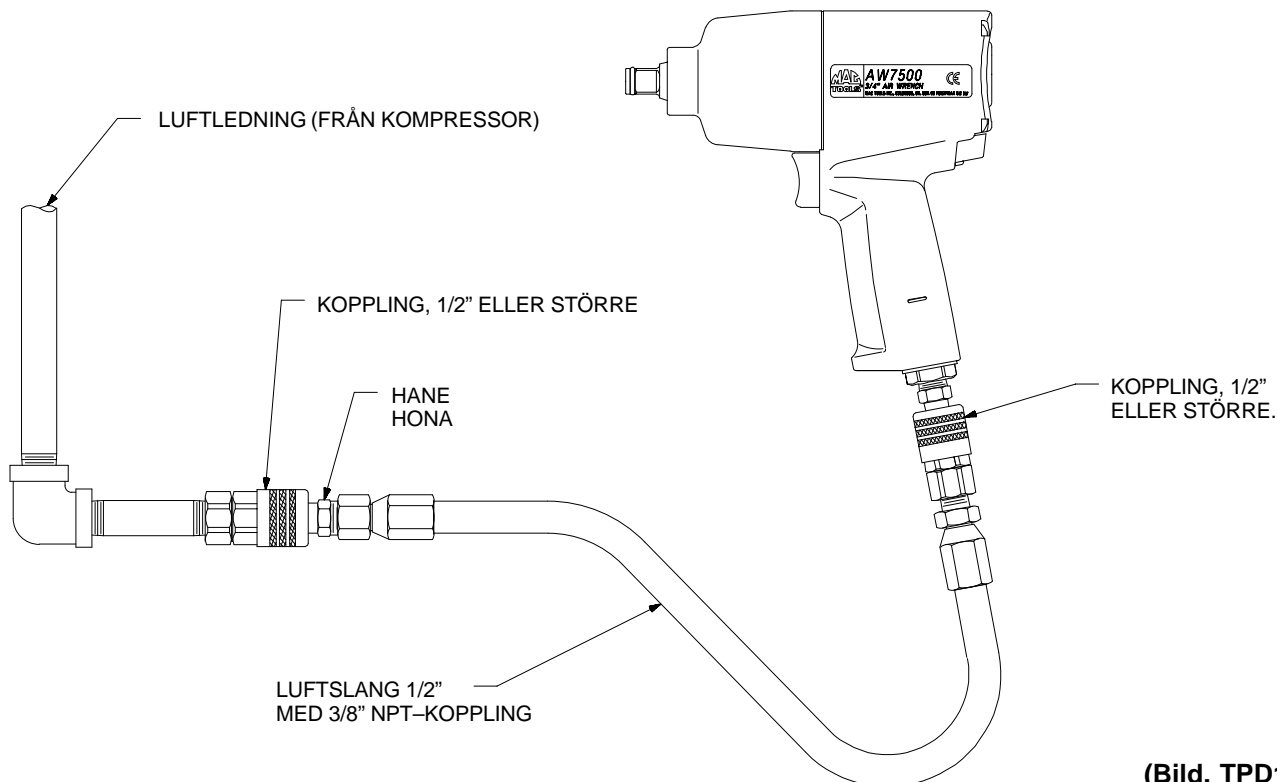

(Bild. TPD1814)

# INNAN VERKTYGET ANVÄNDS

## SPECIFIKATIONER

Modell	Handtag	Fyrkantstapptum	Fri hastighet	Rekommenderat momentområde	
				Framåt ft.lbs (Nm)	Bakåt ft.lbs (Nm)
AW7500	Pistogrepp	3/4	1 175	200–900 [1100 max] (271–1220 [1492 max] )	200–900 [1200 max] (271–1220 [1627 max] )

Modell	■ Ljudtrycksnivå dB(A)		◆ Vibrationsnivå
	Tryck	Effekt	m/s <sup>2</sup>
AW7500	102,9	115,9	5,9

- Testad i enlighet med PNEUROP PN8NTC1.2
- ◆ Testad i enlighet med ISO 8662–7 belastad med friktionsbroms till 9 varv/min

AW7500

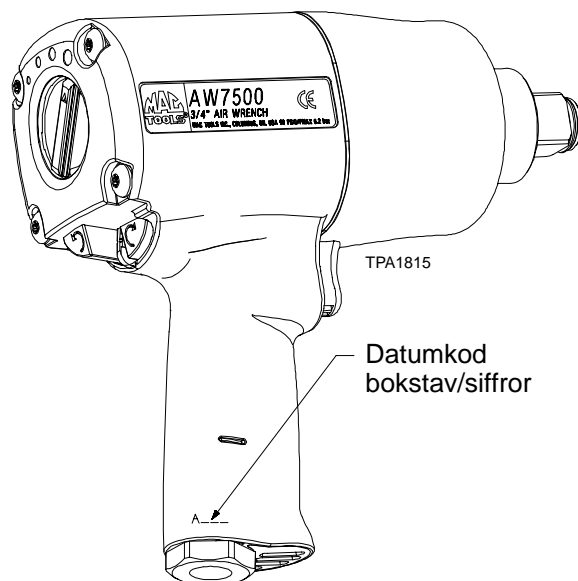

## FÖRSÄKRAN OM ÖVERENSSTÄMMELSE

Vi Mac Tools  
(leverantörens namn)

Columbus, OHIO 43232 USA

(adress)

intygar härmed, i enlighet med vårt fullständiga ansvar, att produkten,

Mutterdragare med slagmekanism, modell AW7500

som detta intyg avser, uppfyller kraven i

98/37/EG Direktiven.

Genom att använda följande principstandard: ISO8662, PNEUROP PN8NTC1

Serienummer, mellan: (2000 →) A00H XXXXX →

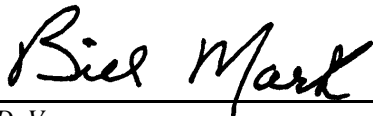

D. Vose

Auktoriserade personers namn och underskrift

September 2000

Datum

**OBS!**

**SPARA ANVISNINGARNA. FÅR EJ FÖRSTÖRAS.**

Då verktyget är utslitet, rekommenderar vi att det tas isär och avfettas,  
samt att de olika delarna sorteras för återvinning.

**INSTRUKSJONER FOR  
MODELL AW7500 EKSTRA KRAFTIG  
MUTTERTREKKERE****MERK**

Modell AW7500 Ekstra kraftige muttertrekere er konstruert for generelt vedlikehold av vei- og terrenggående lastebiler, busser og landbruksmaskiner.

Mac Tools er ikke ansvarlig for verktøymodifikasjoner som utføres av kunden hvor Mac Tools ikke er rådspurt.

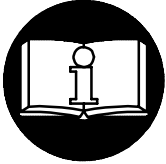
**⚠ ADVARSEL**

**INNEHOLDER VIKTIGE SIKKERHETSINFORMASJONER.  
LES DENNE INSTRUKSJONSHÅNDBOKEN FØR VERKTØYET TAS I BRUK.**

**DET ER ARBEIDSGIVERENS PLIKT Å GI INFORMASJONENE I DENNE  
INSTRUKSJONSBOKEN TIL BRUKEREN.**

**ALVORLIGE PERSONSKADER KAN OPPSTÅ HVIS IKKE FØLGENDE ADVARSLER BLIR  
TATT TIL FØLGE.**

**FØRSTEGANGSBRUK AV VERKTØY**

- Bruk, inspiser og vedlikehold alltid dette verktøyet i følge eksisterende lokale og nasjonale forskrifter for håndholdt trykkluftverktøy.
- For best sikkerhet, topp ytelse og maksimal levetid på deler bør dette verktøyet brukes ved maksimalt lufttrykk på 6,2 bar/620 kPa (90 psig) målt ved luftinntaket når en 13 mm (1/2") innvendig diameter trykkslange brukes.
- Steng alltid av lufttilførselen og koble fra lufttilførselslangen før installering, fjerning eller justering av tilbehør, eller før vedlikehold blir utført på dette verktøyet.
- Bruk ikke en skadet, sprukket eller slitt luftslange/kobling.
- Sørg for at alle slanger og koblinger er av riktig størrelse og er tette. Se tegning TPD905-1 for et typisk koblingsarrangement.
- Bruk alltid ren, tørr luft ved 90 psig maksimalt lufttrykk. Støv, etsende gasser og/eller for mye fuktighet kan ødelegge motoren på et trykkluftverktøy.
- Smør ikke verktøyene med brennbare eller ustabile væsker som parafin, diesel eller flybensin.
- Ikke fjern noen merkelapper. Skift ut eventuelle skadede merkelapper.
- Det anbefales å bruke en forsterket slange. En kopling direkte på luftinntaket øker verktøyets omfang og reduserer manøvreringsevnen.
- Bruk alltid verktøyet med en lufttilførsel-slange med en indre diameter på 10mm. For maksimum yteevne bør koplingen på veggen være en størrelse større enn koplingen som benyttes på verktøyet. Koplingen som er nærmest verktøyet bør ikke være mindre enn den riktige størrelsen på lufttilførsel-slangen.

**BRUK AV VERKTØY**

- Bruk alltid vernebriller under arbeid med eller vedlikehold av dette verktøy.
- Bruk alltid hørselvern under arbeid med dette verktøy.
- Hold hender, løse klær og langt hår unna rotasjonsdelen på verktøyet.
- Vær oppmerksom på innstillingen av reverseringsknappene eller -mekanismen før verktøyet tas i bruk, slik at man er klar over i hvilken retning verktøyet roterer når man bruker trottelen.
- Forutse, og vær forberedt på plutselige bevegelsesforandringer ved oppstart og bruk av ethvert trykkluftverktøy.
- Hold kroppen i en balansert og fast stilling. Len deg ikke for langt forover under bruken av dette verktøyet. Høye reaksjonsmomenter kan forekomme ved lavere lufttrykk enn det som er anbefalt.
- Verktøyets aksel kan fortsette å rotere en kort stund etter trottelen er frigjort.
- Trykkluftverktøy kan vibrere under bruk. Vibrasjon, gjentatte bevegelser eller ubekvemme stillinger kan være skadelig for hender og armer. Stans bruken av ethvert verktøy ved ubehag, stikkende følelser eller hvis du får smerter. Søk råd fra lege før videre arbeid gjenopptas.
- Bruk tilbehør som er anbefalt av Mac Tools.
- Bare benytt kraftpiper og tilbehør. Ikke bruk piper (krom) eller tilbehør.
- Muttertrekere er ikke momentnøkler. Tilkoplinger som trenger spesielt dreiemoment må sjekkes med et momentmeter etter at de er montert med en muttertrekere.
- Dette verktøyet er ikke beregnet til bruk på steder der det er fare for eksplosjon.
- Dette verktøyet er ikke isolert mot elektriske støt.

**MERK**

Bruk av andre deler enn originale Mac Tools reservedeler kan føre til sikkerhetsrisiko, redusert verktøyytelse og økt vedlikehold, og vil føre til at garantien blir ugyldig.

Reparasjoner bør bare utføres av autorisert personell. Konsulter nærmeste autoriserte Mac Tools servicesenter.



## VARSELSYMBOLER

### ⚠ ADVARSEL

ALVORLIGE PERSONSKADER KAN OPPSTÅ HVIS IKKE FØLGENDE ADVARSLER BLIR TATT TIL FØLGE.

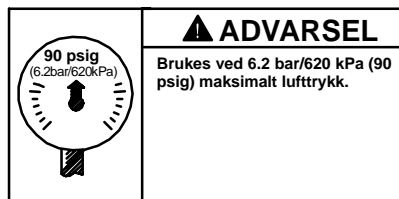
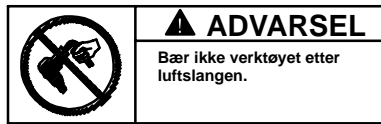
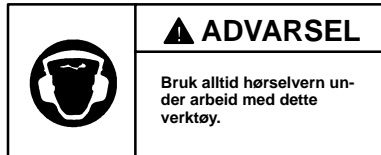
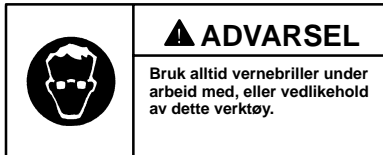

## BRUK AV SYSTEMET FOR EFFEKTKONTROLL

### ⚠ ADVARSEL

Luftskrunøkler er ikke verktøy med momentkontroll. Festelementer med spesielle momentkrav må sjekkes med et passende redskap for momentmåling etter installasjon med en luftskrunøkkel.

### MODELL AW7500 SYSTEM FOR EFFEKTKONTROLL

INDIKATORER FOR EFFEKTTINNSTILLING

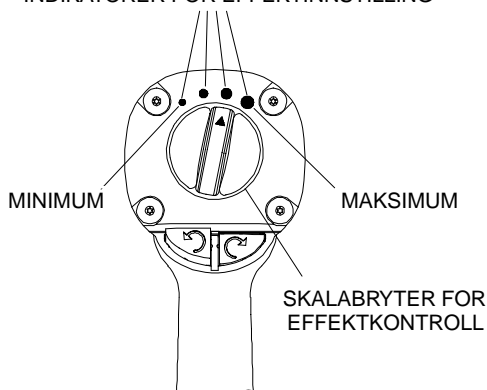

(Tegn. TPD2035)

Modell AW7500 hamrende muttertrekkere har et innebygget system for effektkontroll som gjør at brukeren kan velge fire innstillinger for utgangseffekt. Disse innstillingene går fra minimum utgangseffekt til maksimum utgangseffekt bare i retning forover. **Luftskrunøkkel vil alltid virke med maksimum utgangseffekt i revers, uansett hvilket nivå man har valgt for utgangseffekt.**

### ⚠ ADVARSEL

De fire indikatorene av tiltagende størrelse for effekttinnstilling på baksiden av maskinhuset, som indikerer økende nivå for utgangseffekt, er kun ment som referanse og viser **IKKE** en spesiell utgangseffekt. Den minste effekttinnstillingen angir minimum utgangseffekt, de to midtre effekttinnstillingene angir middels utgangseffekt, og den største effekttinnstillingen angir maksimum utgangseffekt. Utgangseffekten kan reduseres videre i forover og revers ved bruk av den variable pådragsventilen. Lufttilførselsystemer som ikke leverer tilstrekkelig lufttrykk kan påvirke utgangseffekten ved alle innstillinger.

# FØRSTEGANGSBRUK AV VERKTØY

## SMØRING



### Mac Tools Pneumatic



**Bruk Mac Tools Pneumatic** for rutinemessige eksterne smøringer av støtmekanismen gjennom hammerhusets smøreanordning.

**Bruk Mac Tools Pneumatic** når støtmekanismen demonteres og monteres.

Bruk alltid en smørepotte sammen med disse verktøyene. Vi anbefaler følgende filter-smøre-regulator enhet:

For USA – nr. C18-03-FKG0-28  
Internasjonalt – C18-C3-FKG0

## OBS

Sett ikke noe kundeidentifikasjoner på noen del av dette verktøyet som ikke er metall. Hvis det gjøres kan dette virke inn på ytelsen av verktøyet.

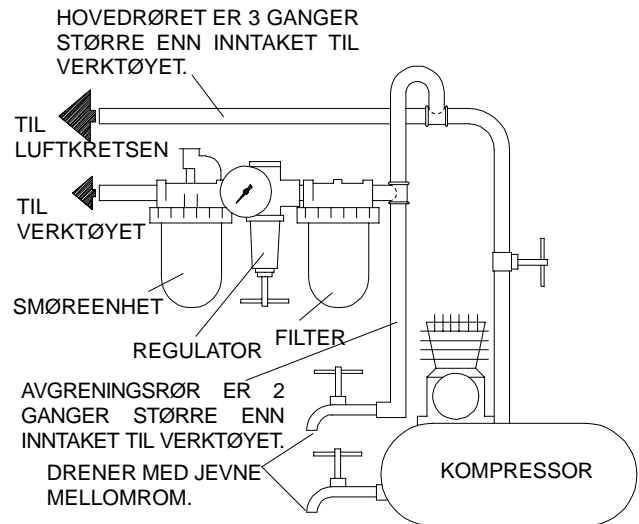

(Tegning TPD905-1)

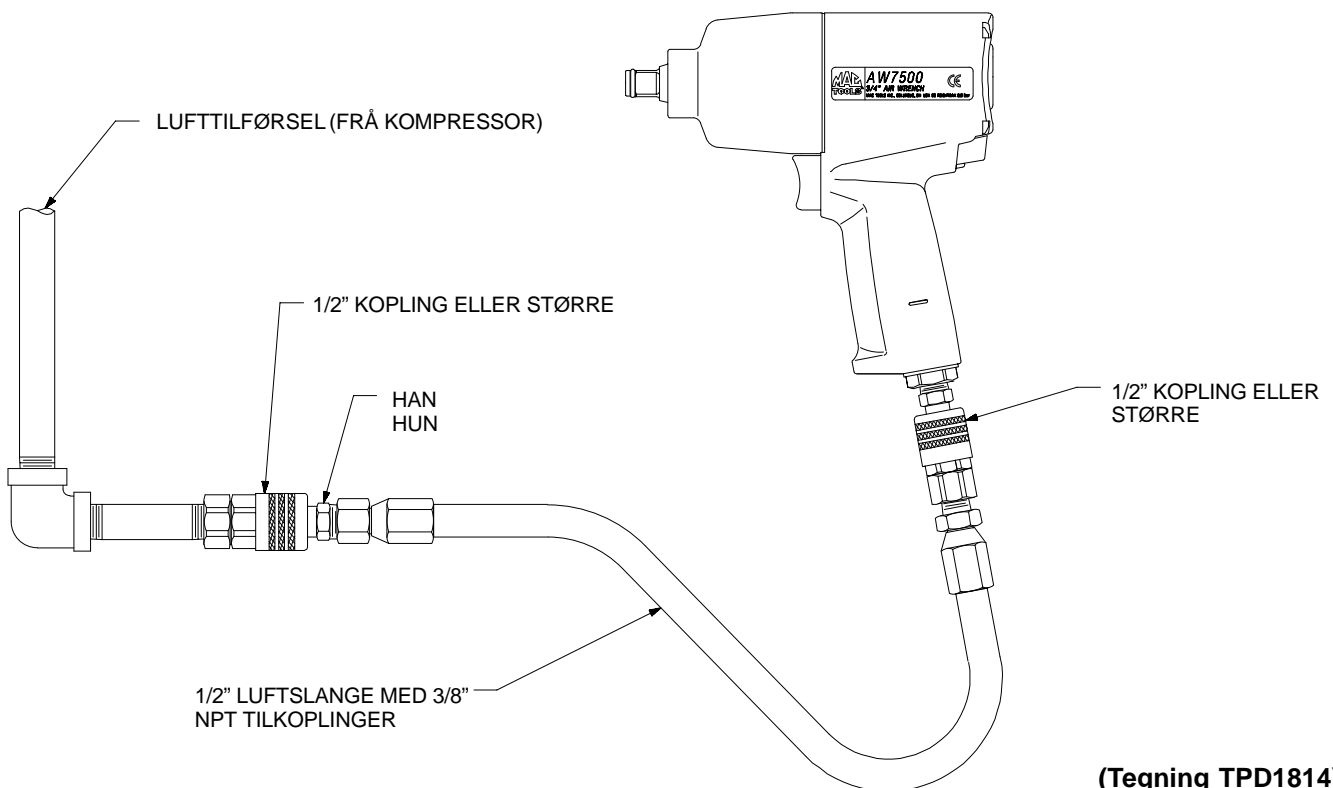

(Tegning TPD1814)

# FØRSTEGANGSBRUK AV VERKTØY

## SPESIFIKASJONER

Modell	Type håndtak	Firkant tapp	Fri hastighet	Anbefalt momentområde	
				Forover ft-lb (Nm)	Revers ft-lb (Nm)
AW7500	Pistolgrep	3/4"	1,175	200–900 [1100 maks] (271–1220 [1492 maks] )	200–900 [1200 maks] (271–1220 [1627 maks] )

Modell	■ Lydnivå dB (A)		◆ Vibrasjons- nivå
	Trykk	Effekt	m/s <sup>2</sup>
AW7500	102,9	115,9	5,9

- Testet i henhold til PNEUROP PN8NTC1.2
- ◆ Testet til ISO8662–7 belastet med friksjonsbrems til 9/RPM

**AW7500**

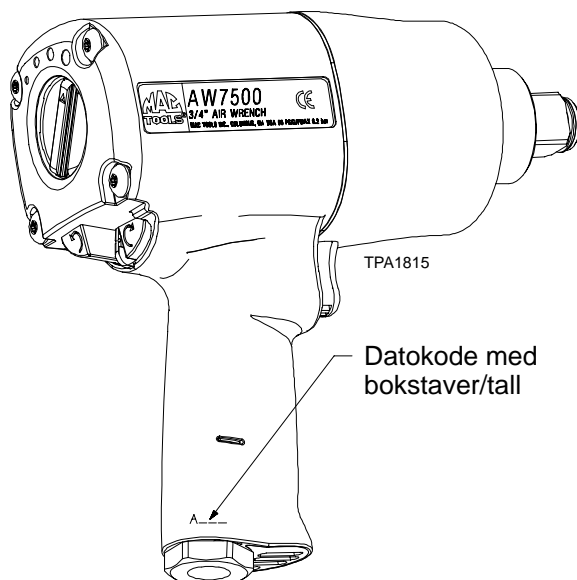

**KONFORMITETSERKLÆRING**

Vi Mac Tools  
(leverandørens navn)

Columbus, OHIO 43232 USA  
(adresse)

erklærer på ære og samvittighet at produktet,

Modell AW7500 Ekstra Kraftig Muttertrekkere

som denne erklæringen gjelder for, oppfyller bestemmelsene i

98/37/CE *directivene.*

ved å bruke følgende prinsipielle standarder: ISO8662, PNEUROP PN8NTC1

Serienr.: (2000 →) A00H XXXXX →

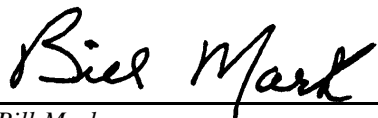

*Bill Mark*  
Navn og underskrift til autoriserte personer

September 2000  
Dato

**MERK**

**OPPBEVAR DISSE INSTRUKSJONENE. ØDELEGG DEM IKKE.**

**Når verktøyet ikke lenger er brukbart, anbefales det at verktøyet blir demontert, rengjort for olje og sortert etter materialer i gjenvinningsøyemed.**

## ERITTÄIN SUURITEHOINEN AUTOALAN ULTRA-DUTY -IMPULSSIIVAIMET AW7500 KÄYTTÖOHJEET

### HUOMAA

Ultra Duty -mutterinvääntimet AW7500 on tarkoitettu kuorma-autojen, maansiirtoautojen, linja-autojen ja maatalouskoneiden huoltoon. Mac Tools ei ole vastuussa työkalujen mahdollisista modifikaatioista muihin sovelluksiin, joista Mac Tools ille ei ole tiedoitettu.

### VAROITUS

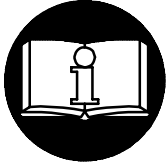

**OHJEISSA ON MUKANA TÄRKEITÄ TURVAOHJEITA.  
LUE TÄMÄ OHJEKIRJA ENNENKUIN ALAT KÄYTTÄÄ TYÖKALUJA.  
TYÖNANTAJAN VELVOLLISUUS ON SAATTAA TÄMÄ  
OHJEKIRJA TYÖNTEKIJÖIDEN TIETOOIN.**

**SEURAAVIEN VAROITUSTEN LAIMINLYÖMINEN SAATTAA JOHTAA VAMMAUTUMISEEN.**

### TYÖKALUJEN KÄYTTÖÖNOTTO

- Käytä, tarkasta ja huolla tätä työkalua aina kaikkien käsikäyttöisiin ilmanpaineella toimiviin työkaluihin liittyvien säännösten mukaisesti (Työturvallisuuslaitoksen määräykset yms.)
- Käytä työkalua enintään 6,2 barin työpaineella ja liitä se 13 mm (1/2") paineilmaletkuun, jotta työkalu toimisi mahdollisimman tehokkaasti, turvallisesti ja pitkäikäisesti.
- Kytke paineilma aina pois päältä ja irroita paineilmaletku ennen kuin asennat, poistat tai säädät mitään tämän työkalun lisälaitetta tai ennen kuin alat huoltaa työkalua.
- Älä käytä vahingoittuneita, hankautuneita tai kuluneita paineilmaletkuja tai -liittimiä.
- Varmistu, että kaikki paineilmaletkut ja -liittimet ovat oikeaa kokoa ja ne ovat tiiviisti kiinni. Katso kuvasta TPD905-1 kaaviota tavanomaisesta paineilmaletkennästä.
- Käytä aina puhdasta, kuivaa paineilmaa, jonka paine on enintään 6,2 bar. Pöly, ruostehöyryt ja/tai liika kosteus saattavat vahingoittaa työkalun paineilmamootoria.
- Älä voitele työkalua tulenaroilla tai helposti haihtuvilla nesteillä, kuten dieselöljyllä, kerosiinilla tai Jet-A-polttoaineella.
- Älä poista mitään työkalussa olevia tarroja. Vaihda vahingoittuneet tarrat.
- Suosittelemme käyttöön letkun tukilaitetta, joka estää letkua kiertymästä mutkalle. Suoraan ilman sisääntuloaukkoon kytketty liitin lisää työkalun massaa ja vaikeuttaa työkalun käsittelyä.
- Mahdollisimman tehokkaan toiminnan varmistamiseksi seinään kiinnitetyn liittimen pitää olla kooltaan yhtä kokoa suurempi kuin työkaluun kytketyn liittimen. Työkalua lähimmäksi kytketty liitin ei saa olla kooltaan asianmukaista ilmansyöttöletkua pienempi.

### TYÖKALUN KÄYTTÖ

- Käytä aina suojalaseja työkalua käyttäessäsi tai huoltaessasi.
- Käytä aina kuulosuojaimia työkalua käyttäessäsi.
- Pidä kädet, irtoton vaatetus ja hiukset loitolla työkalun pyörivästä päästä.
- Ota huomioon suunnanvaihtopainikkeiden tai mekanismin asento ja pyörimissuunta ennen työkalun käynnistämistä.
- Ennakoi ja varo työkalun käynnistyksen ja käytön aikana työkalun liikkeen ja voimien äkkinäisiä muutoksia.
- Seiso tukevassa asennossa hyvässä tasapainossa. Älä kurkota käyttäessäsi työkalua. Työkaluun saattaa yllättäen tulla voimakkaita vääntöliikkeitä sekä suositellulla ilmanpaineella että sitä pienemmällä paineella toimittaessa.
- Työkalun akseli saattaa pyöriä vielä hetken aikaa käynnistysvivusta irtipäästämisen jälkeenkin.
- Paineilmatyökalut voivat tärinästä toimissaan. Tärinä, toistuvat liikesarjat tai epämiellyttävät asennot saattavat olla vahingollisia käsillesi ja käsivarsillesi. Lopeta työkalun käyttö, jos alat tuntea kihelmöintiä ja kipua. Käänny lääkärin puoleen ennen kuin jatkat työkalun käyttöä.
- Käytä Mac Toolsin suosittelemia lisälaitteita.
- Käytä ainoastaan iskutyökaluihin tarkoitettuja hylsyjä ja lisäosia. Älä käytä käsityökaluihin tarkoitettuja (kromattuja) hylsyjä ja lisäosia.
- Iskutyökalut eivät ole momenttityökaluja. Liitokset, jotka vaativat tiettyä kiristysvääntömomenttia tulee tarkastaa momenttiavaimella iskutyökalulla tehdyn esikiristyksen jälkeen.
- Tämä työkalu ei ole suunniteltu käytettäväksi räjähdysalttiissa ympäristöissä.
- Tämä työkalu ei ole eristetty sähköiskujen varalta.

### HUOMAA

Muiden kuin Mac Toolsin alkuperäisvaraosien käyttö saattaa johtaa vaaratilanteisiin, heikentyneisiin työkalun suoritusarvoihin, kasvavaan huollontarpeeseen ja se saattaa mitätöidä kaikki takuut.

Ainostaan valtuutetun, koulutetun henkilöstön tulisi korjata työkalua. Lisätietoja saat lähimmästä Mac Toolsin merkkihuoltokeskuksesta.

## VAROITUSTARROJEN TULKINTAOHJEITA

### VAROITUS

SEURAAVIEN VAROITUSTEN LAIMINLYÖMINEN SAATTAA JOHTAA VAMMAUTUMISEEN.

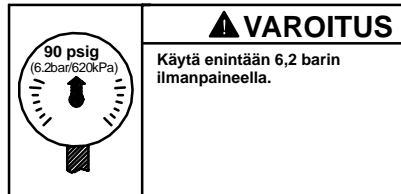
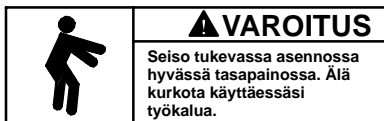
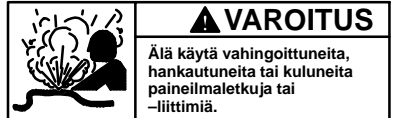
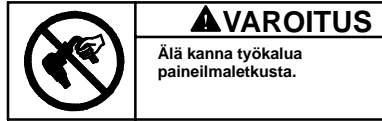
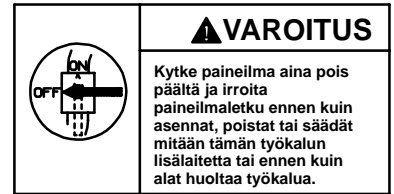
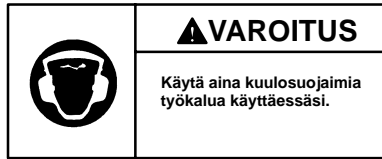
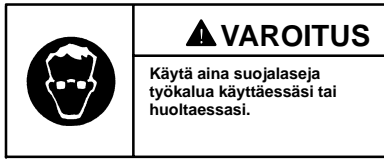

## TEHONSÄÄTÖJÄRJESTELMÄN KÄYTTÄMINEN

### VAROITUS

Ilmakäyttöiset vääntimet eivät ole momenttiavaimia. Kun kiinnike edellyttää tiettyä momenttia, se on tarkastettava sopivalla mittavälineellä, kun kiinnike on asennettu ilmatyökalulla.

Iskevissä vääntimissä AW7500 on tehonsäätöjärjestelmä. Työkalun käyttäjä voi valita neljä eri tehoasetusta. Säätöalue ulottuu minimitehosta maksimitehoon käytettäessä työkalua normaaliin suuntaan. **Taaksepäin käyvä työkalu toimii aina täydellä teholla säätimen asennosta riippumatta.**

### VAROITUS

#### TEHONSÄÄTÖJÄRJESTELMÄT AW7500

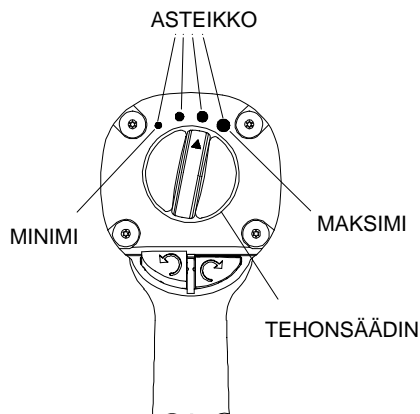

Kotelon takapään merkinnät vastaavat vain kasvavia tehoja. Ne **EIVÄT** ilmaise tiettyä tehoa. Pienin merkki vastaa pienintä tehoa, kaksi keskimmäistä keskisuuria tehoja ja suurin merkki maksimitehoa.

Tehoa voidaan pienentää kummassakin käyntisuunnassa käyttämällä säätöventtiiliä. Ilmansyöttöjärjestelmän riittämätön paine voi vaikuttaa tehon kaikissa asennoissa.

# TYÖKALUN KÄYTTÖNOTTO

## VOITELU



### Mac Tools Pneumatic



Mac Tools Pneumatic on tarkoitettu iskumekanismin ulkopuoliseen voiteluun työkalun rungossa olevan voitelunipan kautta.

Käytä iskumekanismin purkamiseen ja kokoamiseen Mac Tools Pneumatic-tuotteita.

Käytä aina paineilma-voitelua työkalujen yhteydessä. Suosittelemme seuraavaa suodatin-voitelu-paineensäätö-yhdistelmälaitetta:

Käytössä Amerikan Yhdysvalloissa – nro. C18-03-FKG0-28  
Kansainvälisessä käytössä – nro. C18-C3-FKG0

## VAROITUS

Älä tee mihinkään tämän työkalun epämetallisista materiaaleista valmistettuun pintaan merkintöjä (esim. syövytyt tai kaiverretut asiakastunnukset). Tällaisilla merkinnöillä saattaa olla vaikutus työkalun suoritusarvoihin.

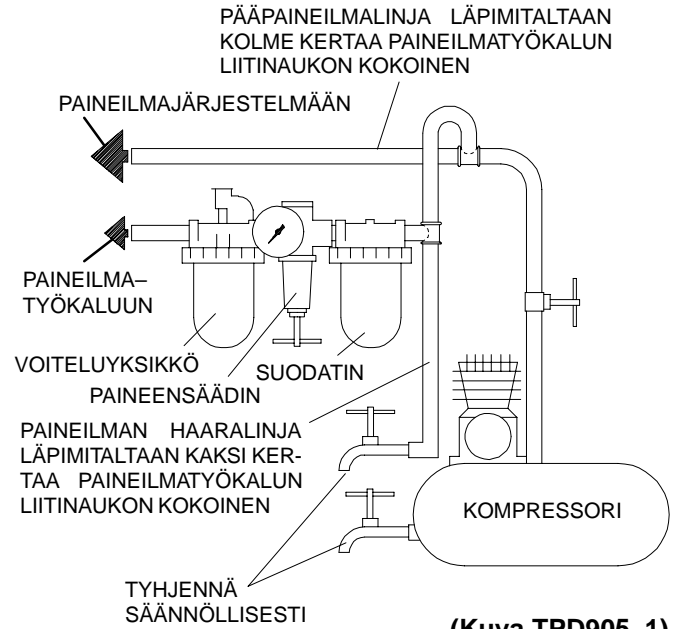

(Kuva TPD905-1)

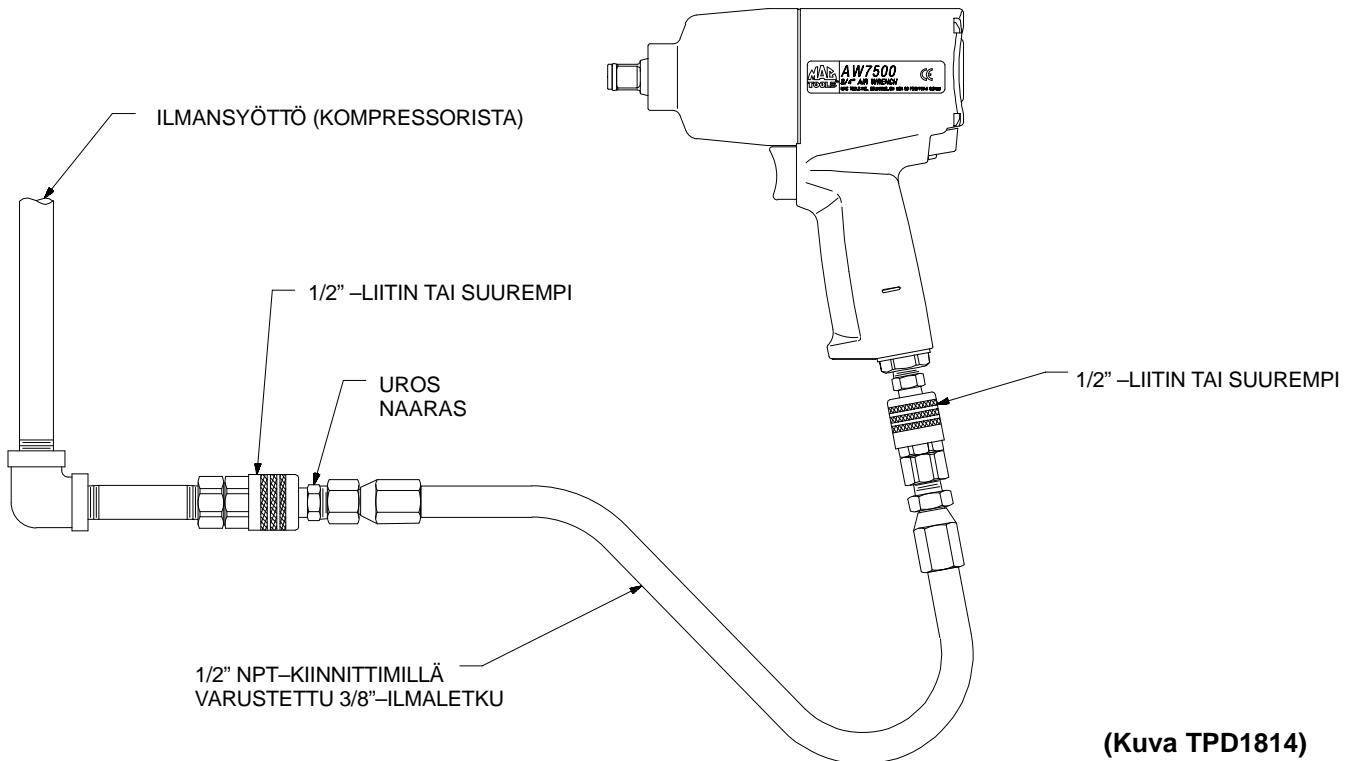

(Kuva TPD1814)

# TYÖKALUN KÄYTTÖNOTTO

## ERITTELY

Malli	Kädensijaty- yppi	Vääntö	Iskuja/ minuutti	Suositeltu vääntömomenttialue	
				Eteenpäin ft-lb (Nm)	Taaksepäin ft-lb (Nm)
AW7500	Pistooli	3/4" neliö	1 175	200–900 [1100 maks] (271–1220 [1492 maks] )	200–900 [1200 maks] (271–1220 [1627 maks] )

Malli	■ Äänivoimakkuustaso dB (A)		◆ Värinä
	Paine	Teho	m/s <sup>2</sup>
AW7500	102,9	115,9	5,9

- Testattu PNEUROP PN8NTC1.2:n vaatimusten mukaisesti
- ◆ Koestettu ISO8662–7 mukaisesti kuormitettuna kitkajarrulla 9 1/min saakka.

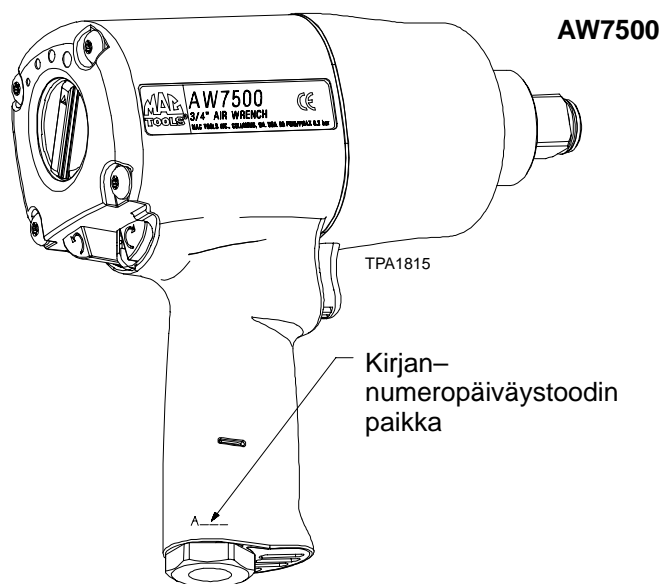



## VAKUUTUS NORMIEN TÄYTTÄMISESTÄ

*Me* \_\_\_\_\_ *Mac Tools*  
(toimittajan nimi)

\_\_\_\_\_ *Columbus, OHIO 43232 USA*

(osoite)

vakuutamme ja kannamme yksin täyden vastuun siitä, että tuote

\_\_\_\_\_ *Erittäin suuritehoinen autoalan Ultra Duty –impulssiavaimet AW7500*

johon tämä vakuutus viittaa, täyttää direktiiveissä

\_\_\_\_\_ *98/37/EY*

esitetty vaatimukset seuraavia perusnormeja käytettäessä. *ISO8662, PNEUROP PN8NTC1*

Sarjanumerot: \_\_\_\_\_ *(2000 → ) A00H XXXXX →*

*Bill Mark*

\_\_\_\_\_ *Bill Mark*

Autorisoidun henkilön nimi ja asema

\_\_\_\_\_ *Syyskuu, 2000*

Päiväys

### **HUOMAA**

**SÄÄSTÄ NÄMÄ OHJEET. ÄLÄ TUHOA NIITÄ.**

Kun tämä työkalun käyttöikä on loppunut, suosittelemme työkalun purkamista, puhdistusta rasvasta ja eri materiaalien erittelyä kierrätystä varten.

## INSTRUÇÕES PARA CHAVES DE PERCUSSÃO PARA AUTOMÓVEIS PARA TRABALHO ULTRA PESADO MODELO AW7500

### AVISO

As Chaves de Percussão para Trabalho Ultra Pesado modelo AW7500 são concebidas para manutenção geral de autocarros, equipamento agrícola e camiões para todo o terreno.

A Mac Tools não pode ser responsabilizada pela modificação de ferramentas para aplicações para as quais não tenha sido consultada.

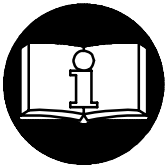

### ⚠️ ADVERTÊNCIA

**IMPORTANTES INFORMAÇÕES DE SEGURANÇA EM ANEXO.  
LEIA ESTE MANUAL ANTES DE OPERAR A FERRAMENTA.  
É RESPONSABILIDADE DA ENTIDADE PATRONAL PÔR AS INFORMAÇÕES  
CONTIDAS NESTE MANUAL À DISPOSIÇÃO DOS UTILIZADORES.  
A NÃO OBEDEIÊNCIA ÀS ADVERTÊNCIAS SEGUINTE PODERÁ RESULTAR EM  
LESÕES PESSOAIS.**

#### COLOCAÇÃO DA FERRAMENTA EM SERVIÇO

- Opere, inspecione e faça manutenção nesta ferramenta sempre de acordo com todos os regulamentos (locais, estatais, federais e nacionais) que possam ser aplicáveis a ferramentas pneumáticas de mão/funcionamento manual.
- Para segurança, desempenho superior e durabilidade máxima das peças, opere esta ferramenta a uma pressão de ar máxima de 90 psig (6,2 bar/620 kPa) na admissão com uma mangueira de alimentação de ar com diâmetro interno de 1/2 pol. (13 mm).
- Desligue sempre a alimentação de ar e a mangueira de alimentação de ar antes de instalar, retirar ou ajustar qualquer acessório desta ferramenta, ou antes de fazer manutenção na mesma.
- Não utilize mangueiras de ar e acessórios danificados, puídos ou deteriorados.
- Certifique-se de que todas as mangueiras e acessórios são da dimensão correcta e que estão seguros firmemente. Consulte o Des. TPD905-1 para uma disposição de tubos típica.
- Utilize sempre ar limpo e seco a uma pressão máxima de 90 psig. Poeira, fumos corrosivos e/ou humidade excessiva podem destruir o motor de uma ferramenta pneumática.
- Não lubrifique a ferramenta com líquidos inflamáveis ou voláteis como querosene, gasóleo ou combustível para jactos.
- Não retire nenhum rótulo. Substitua os rótulos danificados.
- Recomenda-se utilizar um reforço de mangueira. Um acoplador ligado directamente à admissão do ar aumenta o volume da ferramenta e diminui a capacidade de manobra da mesma.
- Sempre opere esta ferramenta com uma mangueira de alimentação de ar com diâmetro interno de 3/8 pol. (10 mm). Para obter o desempenho máximo, o acoplador na parede deve ser um tamanho maior do que o acoplador utilizado na ferramenta. O acoplador mais próximo à ferramenta não deve ser menor do que o tamanho correcto da mangueira de alimentação de ar.

#### UTILIZAÇÃO DA FERRAMENTA

- Use sempre protecção para os olhos ao operar ou fazer manutenção nesta ferramenta.
- Use sempre protecção auricular ao operar esta ferramenta.
- Mantenha as mãos, roupas soltas e cabelos longos afastados da extremidade rotativa da ferramenta.
- Note a posição dos botões ou mecanismo de inversão antes de operar a ferramenta de forma a estar ciente da direcção de rotação ao operar o regulador.
- Esteja preparado e alerta para mudanças súbitas no movimento durante o arranque e o funcionamento de qualquer ferramenta mecânica.
- Mantenha o corpo numa posição equilibrada e firme. Não estique o corpo ao operar esta ferramenta. Podem ocorrer binários de reacção elevados à ou abaixo da pressão do ar recomendada.
- O veio da ferramenta pode continuar a rodar por um curto período de tempo depois de soltar o regulador.
- As ferramentas pneumáticas podem vibrar durante a utilização. Vibração, movimentos repetitivos ou posições desconfortáveis podem ser nocivos às suas mãos e braços. Pare de utilizar qualquer ferramenta se ocorrer desconforto, sensação de formigueiro ou dor. Procure assistência médica antes de reiniciar a utilização.
- Use os acessórios recomendados pela Mac Tools.
- Use apenas caixas e acessórios de percussão. Não use caixas e acessórios manuais (cromo).
- As chaves de percussão não são chaves dinamométricas. As ligações que precisem de um valor específico de binário devem ser verificadas com um dinamómetro após serem montadas com uma chave de percussão.
- Esta ferramenta não é concebida para funcionar em atmosferas explosivas.
- Esta ferramenta não é isolada contra choque eléctrico.

### AVISO

A utilização de qualquer peça sobresselente que não seja Mac Tools genuína pode resultar em riscos à segurança, em desempenho reduzido da ferramenta e mais necessidade de manutenção, e pode invalidar todas as garantias.

As reparações só devem ser feitas por pessoal autorizado e com formação adequada. Consulte o Representante Autorizado Mac Tools mais próximo.

# IDENTIFICAÇÃO DAS ETIQUETAS DE ADVERTÊNCIA

## ⚠ ADVERTÊNCIA

A NÃO OEDIÊNCIA ÀS ADVERTÊNCIAS SEGUINTE PODERÁ RESULTAR EM LESÕES PESSOAIS.

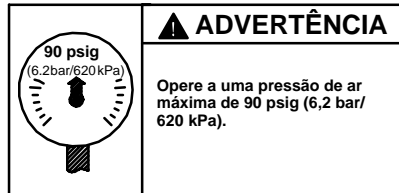
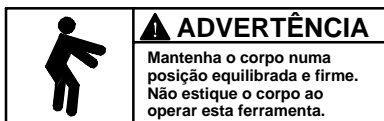
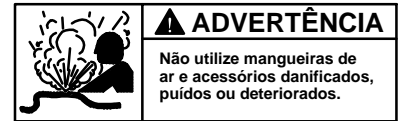
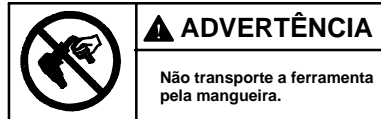

## UTILIZAÇÃO DO SISTEMA DE GESTÃO DE POTÊNCIA

### ⚠ ADVERTÊNCIA

As chaves pneumáticas não são dispositivos de controlo de binário. Os fixadores com requisitos específicos de binário têm que ser verificados com dispositivos de medição de binário adequados após a instalação com uma chave pneumática.

As Chaves de Percussão Modelo AW7500 incorporam um Sistema de Gestão de Potência que permite ao operador seleccionar quatro ajustes de potência. Estes ajustes vão de potência mínima até potência máxima apenas na direcção de avanço. A Chave Pneumática funcionará sempre à potência máxima na direcção de inversão, independentemente do nível de potência seleccionado.

### SISTEMA DE GESTÃO DE POTÊNCIA MODELO AW7500

INDICADORES DE AJUSTE DE POTÊNCIA

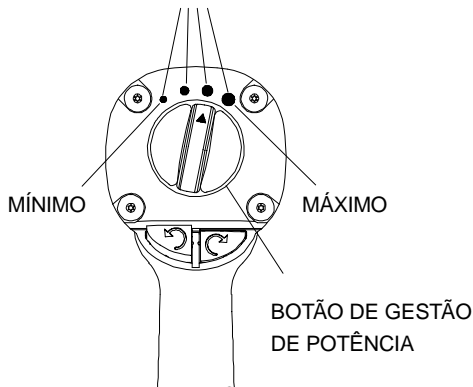

(Des. TPD2035)

### ⚠ ADVERTÊNCIA

Os quatro indicadores de ajuste de potência de tamanho crescente nas costas da carcaça indicam níveis crescentes de potência, são apenas para referência e NÃO indicam uma potência específica. O indicador de ajuste mais pequeno denota potência mínima, os dois indicadores de ajuste intermédios denotam potências médias e o maior indicador de ajuste de potência denota potência máxima. A potência pode ser reduzida ainda mais na direcção de avanço ou de inversão utilizando o regulador variável. Sistemas de alimentação de ar que não proporcionam pressão de ar adequada podem afectar a potência em todos os ajustes.

# COLOCAÇÃO DA FERRAMENTA EM SERVIÇO

## LUBRIFICAÇÃO



### Mac Tools Pneumatic



**Mac Tools Pneumatic** para lubrificação externa rotineira do mecanismo de percussão através do Copo de Massa da Caixa do Martelo.

**Mac Tools Pneumatic** ao desmontar e montar o mecanismo de percussão.

Utilize sempre um lubrificador de linha de ar com estas ferramentas. Recomendamos a seguinte Unidade Filtro–Lubrificador–Regulador:

Para EUA – N°. C18-03-FKG0-28

Para Internacional – N°. C18-C3-FKG0

## CUIDADO

Não marque nenhuma superfície não metálica desta ferramenta com códigos de identificação do cliente. Isto poderia afectar o desempenho da ferramenta.

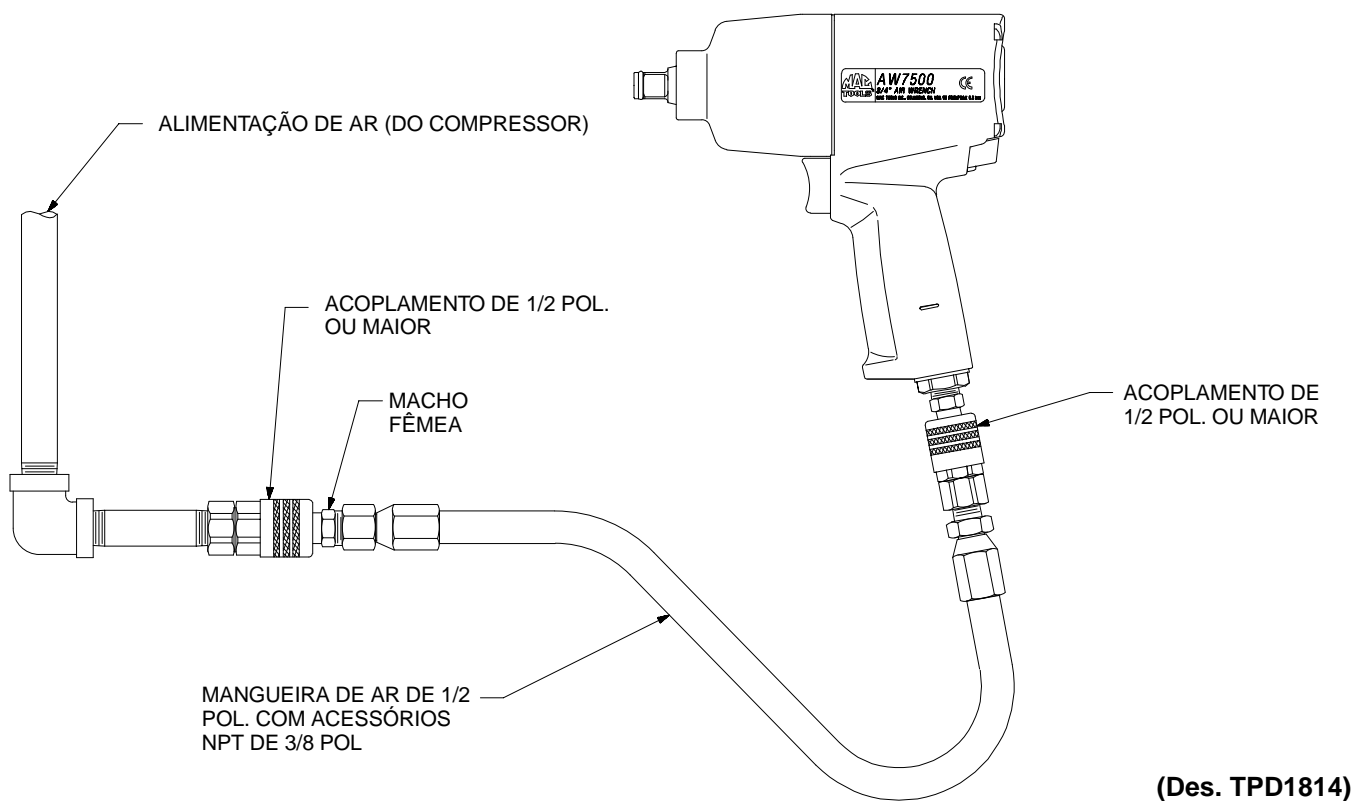
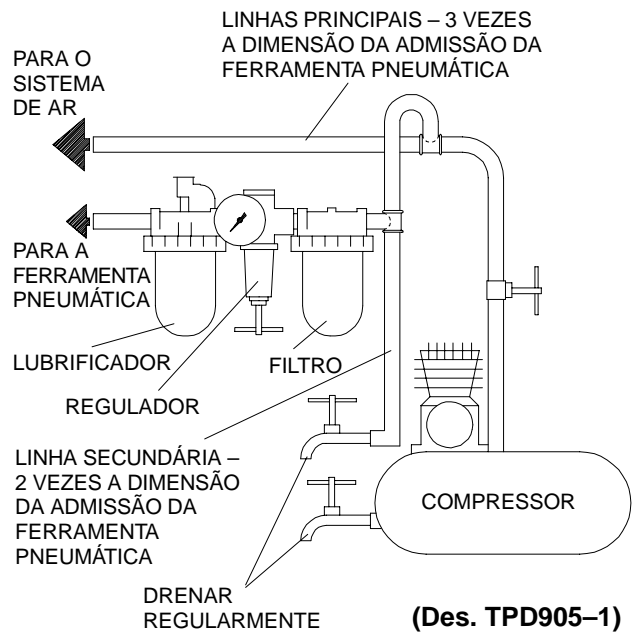

# COLOCAÇÃO DA FERRAMENTA EM SERVIÇO

## ESPECIFICAÇÕES

Modelo	Tipo de Pega	Accionamento	Impactos por min.	Gama de Binário Recomendada	
				Dir. de Avanço ft-lb (Nm)	Dir. Inversa ft-lb (Nm)
AW7500	pistola	3/4 pol	1 175	200-900 [1100 Máx.] (271-1220 [1492 Máx.] )	200-900 [1200 Máx.] (271-1220 [1627 Máx.] )

Modelo	■ Nível de Som dB (A)		◆ Nível de Vibrações m/s <sup>2</sup>
	Pressão	Potência	
AW7500	102,9	115,9	5,9

- Teste de acordo com PNEUROP PN8NTC1.2
- ◆ Testada de acordo com ISO8662-7 carregada com freio de fricção até 9 rpm.

**AW7500**

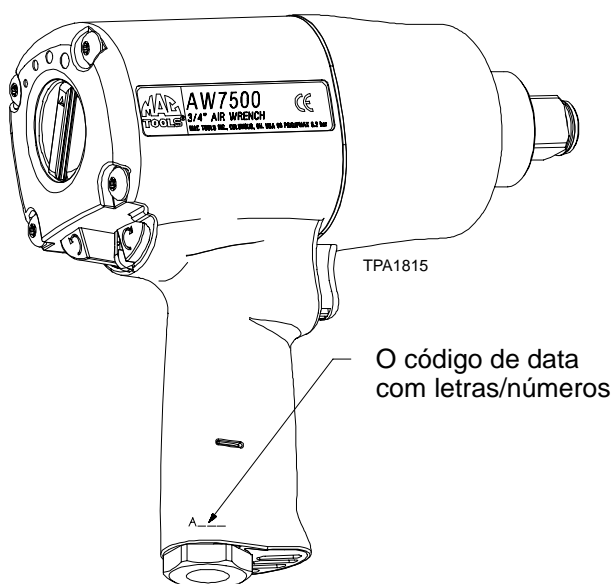

## DECLARAÇÃO DE CONFORMIDADE

Nós Mac Tools  
(nome do fornecedor)

Columbus, OHIO 43232 USA

(endereço)

declaramos sob a nossa exclusiva responsabilidade que o produto,

Chaves de Percussão para Automóveis para Trabalho Ultra Pesado  
Modelo AW7500

ao qual se refere a presente declaração, está de acordo com as prescrições das Directivas

98/37/CE

observando as seguintes Normas Principais: ISO8662, PNEUROP PN8NTC1

Gama de N<sup>os</sup> de Série (2000 → ) A00H XXXXX →

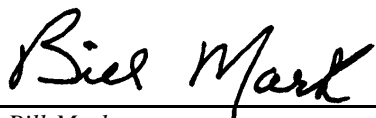

Bill Mark

Nome e assinatura das pessoas autorizadas

Setembro de 2000

Data

### AVISO

CONSERVE ESTAS INSTRUÇÕES. NÃO AS DESTRUA.

Quando a ferramenta não mais funcionar eficazmente, recomenda-se que a mesma seja desmontada, limpa e que as suas peças sejam separadas por tipo de material para poderem ser recicladas.

**ΟΔΗΓΙΕΣ ΓΙΑ  
ΜΟΝΤΕΛΑ AW7500  
ΑΕΡΟΚΛΕΙΔΑ ΥΠΕΡΙΣΧΥΡΑ ΓΙΑ ΕΡΓΑΣΙΕΣ  
ΕΠΙ ΤΡΟΧΟΦΟΡΩΝ**

**ΠΡΟΣΟΧΗ**

Τα Κρουστικά Κλειδιά Υπερβαρείας Χρήσης, μοντέλα AW7500, έχουν σχεδιαστεί για τη γενική συντήρηση λεωφορείων, αγροτικών οχημάτων και φορτηγών οχημάτων χώματος και δρόμου.

Η Mac Tools δεν ευθύνεται για μετατροπές των εργαλείων από τον πελάτη, για εφαρμογές για τις οποίες δεν συμβουλευθήκαν την Mac Tools.



**ΠΡΟΕΙΔΟΠΟΙΗΣΗ**

**ΣΗΜΑΝΤΙΚΕΣ ΠΛΗΡΟΦΟΡΙΕΣ ΠΕΡΙΕΧΟΝΤΑΙ ΣΤΟ ΕΓΧΕΙΡΙΔΙΟ  
ΑΥΤΟ ΓΙΑ ΤΗΝ ΑΣΦΑΛΗ ΛΕΙΤΟΥΡΓΙΑ ΤΟΥ ΕΡΓΑΛΕΙΟΥ.  
ΔΙΑΒΑΣΤΕ ΤΟ ΕΓΧΕΙΡΙΔΙΟ ΑΥΤΟ ΠΡΙΝ ΑΠΟ ΤΗΝ ΛΕΙΤΟΥΡΓΙΑ ΤΟΥ ΕΡΓΑΛΕΙΟΥ.**

**ΕΙΝΑΙ ΕΥΘΥΝΗ ΤΟΥ ΕΡΓΟΔΟΤΗ ΝΑ ΘΕΣΕΙ ΤΙΣ ΠΛΗΡΟΦΟΡΙΕΣ  
ΑΥΤΟΥ ΤΟΥ ΕΓΧΕΙΡΙΔΙΟΥ ΥΠ'ΟΨΗΝ ΤΟΥ ΧΕΙΡΙΣΤΗ.**

**Η ΠΑΡΑΛΕΙΨΗ ΤΗΡΗΣΗΣ ΤΩΝ ΑΚΟΛΟΥΘΩΝ ΠΡΟΕΙΔΟΠΟΙΗΣΕΩΝ  
ΜΠΟΡΕΙ ΝΑ ΟΔΗΓΗΣΕΙ ΣΕ ΤΡΑΥΜΑΤΙΣΜΟ.**

**ΘΕΣΗ ΕΡΓΑΛΕΙΟΥ ΣΕ ΛΕΙΤΟΥΡΓΙΑ**

- Πάντοτε να χειρίζεστε, να επιθεωρείτε και να συντηρείτε το εργαλείο αυτό σύμφωνα με όλους τους κανονισμούς (τοπικούς, περιφερειακούς, κρατικούς) που προσδιορίζουν την κατάλληλη χρήση των εργαλείων αέρος χειρός.
- Για την ασφάλεια, υψηλή απόδοση και μέγιστη ανθεκτικότητα των διαφόρων εξαρτημάτων, λειτουργείτε το εργαλείο αυτό με μέγιστη πίεση αέρος 90 psig (6.2 bar/620 kPa) και με 1/2" (13 χιλ.) εσωτερική διάμετρο σωλήνος παροχής αέρος.
- Διακόπτετε πάντα την παροχή αέρος και αποσυνδέετε το σωλήνα παροχής αέρος πριν την τοποθέτηση, αφαίρεση ή ρύθμιση οποιουδήποτε εξαρτήματος σ' αυτό το εργαλείο, ή πριν την εκτέλεση οποιασδήποτε συντήρησης σ' αυτό το εργαλείο.
- Μη χρησιμοποιείτε σωλήνες και προσαρτήματα με ζημιά, ξεφτισμένα ή φθαρμένα.
- Βεβαιωθείτε ότι όλοι οι σωλήνες και τα προσαρτήματα έχουν το σωστό μέγεθος και είναι στερεά ασφαλισμένα. Βλέπετε σχ. TPD905-1 για μια τυπική διαδικασία σωλήνωσης.
- Χρησιμοποιείτε πάντοτε καθαρό, ξηρό αέρα μεγίστης πίεσεως 90 psig. Η σκόνη, οι διαβρωτικές αναθυμιάσεις και/ή η υπερβολική υγρασία μπορούν να καταστρέψουν τον αεροκινητήρα ενός εργαλείου αέρος.
- Μη λπαινείτε τα εργαλεία με εύφλεκτα ή πτητικά υγρά όπως η κηροζίνη, το ντίζελ ή καύσιμο τζετ.
- Μη αφαιρείτε οποιαδήποτε πινακίδες. Αντικαταστήστε οποιαδήποτε κατεστραμμένη πινακίδα.
- Η χρήση ενός επάρτου για τον σωλήνα συνιστάται. Ένας ζευκτήρας (κόπλερ) συνδεδεμένος κατ' ευθείαν στην εισαγωγή αέρος αυξάνει τον όγκο του εργαλείου και ελαττώνει την ευχρηστία του.
- Πάντα λειτουργείτε το εργαλείο αυτό με 3/8" (10 χιλ.) εσωτερική διάμετρο σωλήνος παροχής αέρος. Για μέγιστη απόδοση, ο ζευκτήρας (κόπλερ) στον τοίχο θά πρέπει να είναι ένα μέγεθος μεγαλύτερος από τον ζευκτήρα (κόπλερ) που χρησιμοποιείται στο εργαλείο. Ο ζευκτήρας κοντήτερα στο εργαλείο δεν θα πρέπει να είναι μικρότερος από το κατάλληλο μέγεθος του σωλήνα παροχής αέρα.

**ΧΡΗΣΙΜΟΠΟΙΗΣΗ ΤΟΥ ΕΡΓΑΛΕΙΟΥ**

- Φοράτε πάντα προστατευτικά των ματιών όταν λειτουργείτε ή εκτελείτε συντήρηση αυτού του εργαλείου.
- Φοράτε πάντα προστατευτικά ακοής όταν λειτουργείτε αυτό το εργαλείο.
- Κρατάτε τα χέρια σας, χαλαρά ενδύματα και μακριά μαλλιά σε απόσταση από την άκρη περιστροφής του εργαλείου.
- Παρατηρήστε τη θέση των πλήκτρων ή του μηχανισμού της όπισθεν πριν χρησιμοποιήσετε το εργαλείο, προκειμένου να γνωρίζετε τη φορά περιστροφής όταν χειρίζεστε το πεντάλ κίνησης.
- Προβλέψτε και να είστε έτοιμοι για τις ξαφνικές αλλαγές στην κίνηση κατά το ξεκίνημα και τη λειτουργία κάθε μηχανοκίνητου εργαλείου.
- Διατηρείτε το σώμα σας σε στάση ισορροπίας και σταθερά. Μην υπερβαίνετε τη θέση ισορροπίας όταν λειτουργείτε αυτό το εργαλείο. Υψηλές ροπές στρέψεως μπορεί να συμβούν στις συνιστώμενες πιέσεις λειτουργίας ή και σε χαμηλότερες.
- Το εξάρτημα του εργαλείου ενδέχεται να συνεχίσει τις περιστροφές για λίγο μετά την αποδέσμευση της δικλίδας αέρος.
- Όλα τα μηχανοκίνητα εργαλεία αέρος δυνατόν να δονούνται κατά τη χρήση τους. Κραδασμοί, επαναλαμβανόμενες κινήσεις και άβολες θέσεις δυνατόν να προκαλέσουν βλάβη στα χέρια και στους βραχίονες σας. Σταματήστε τη χρήση κάθε εργαλείου αν αισθανθείτε στενοχώρια, σουβλιές ή πόνο. Ζητήστε ιατρική συμβουλή πριν επαναλάβετε τη χρήση.
- Χρησιμοποιείτε εξαρτήματα που συνιστά η Mac Tools.
- Χρησιμοποιείτε μόνο υποδοχείς και εξαρτήματα κρούσεως. Μη χρησιμοποιείτε υποδοχείς και εξαρτήματα χειρός (χρωμίου).
- Τα αερόκλειδα δεν είναι κλειδες ροπής. Συνδέσεις που απαιτούν ειδικές ροπές πρέπει να ελέγχονται με εργαλείο μέτρησης ροπής μετά την εφαρμογή τους με ένα αερόκλειδο.
- Το εργαλείο αυτό δεν είναι σχεδιασμένο να λειτουργεί σε εκρηκτικές ατμόσφαιρες.
- Το εργαλείο αυτό δεν είναι μονωμένο έναντι ηλεκτρικού σοκ.

**ΠΡΟΣΟΧΗ**

Η χρήση άλλων εκτός των αυθεντικών ανταλλακτικών της Mac Tools μπορεί να οδηγήσει σε κίνδυνο για την ασφάλεια, να επιφέρει μείωση της απόδοσης του εργαλείου και επαύξηση της συντήρησης και ενδέχεται να ακυρώσει όλες τις εγγυήσεις. Οι επισκευές πρέπει να γίνονται μόνο από εξουσιοδοτημένο εκπαιδευμένο προσωπικό. Συμβουλευτείτε το πλησιέστερο σας Εξουσιοδοτημένο Κέντρο Εξυπηρέτησης (Servicenter) της Mac Tools.

## ΑΝΑΓΝΩΡΗΣΗ ΠΡΟΕΙΔΟΠΟΙΗΤΙΚΩΝ ΠΙΝΑΚΙΔΩΝ

### ▲ ΠΡΟΕΙΔΟΠΟΙΗΣΗ

Η ΠΑΡΑΛΕΙΨΗ ΤΗΡΗΣΗΣ ΤΩΝ ΑΚΟΛΟΥΘΩΝ ΠΡΟΕΙΔΟΠΟΙΗΣΕΩΝ ΜΠΟΡΕΙ ΝΑ ΟΔΗΓΗΣΕΙ ΣΕ ΤΡΑΥΜΑΤΙΣΜΟ.

	<b>▲ ΠΡΟΕΙΔΟΠΟΙΗΣΗ</b> Φοράτε πάντα προστατευτικά ματιών όταν λειτουργείτε ή εκτελείτε συντήρηση αυτού του εργαλείου.		<b>▲ ΠΡΟΕΙΔΟΠΟΙΗΣΗ</b> Φοράτε πάντα προστατευτικά ακουστικά όταν λειτουργείτε αυτό το εργαλείο.		<b>▲ ΠΡΟΕΙΔΟΠΟΙΗΣΗ</b> Διακόπτετε πάντα την παροχή αέρα και αποσυνδέετε το σωλήνα παροχής αέρα πριν την τοποθέτηση, αφαίρεση ή ρύθμιση οποιουδήποτε εξαρτήματος σ' αυτό το εργαλείο, ή πριν την εκτέλεση οποιασδήποτε συντήρησης σ' αυτό το εργαλείο.
	<b>▲ ΠΡΟΕΙΔΟΠΟΙΗΣΗ</b> Όλα τα μηχανοκίνητα εργαλεία δυνατόν να κραδάζονται κατά τη χρήση τους. Κραδασιμοί, επαναλαμβανόμενες κινήσεις και άβολες θέσεις δυνατόν να προκαλέσουν βλάβη στα χέρια και στους βραχίονες σας. Σταματήστε τη χρήση κάθε εργαλείου αν αισθανθήτε στενωχωρία, οσφυβίες ή πόνο. Ζητήστε ιατρική συμβουλή πριν επαναλάβετε τη χρήση.		<b>▲ ΠΡΟΕΙΔΟΠΟΙΗΣΗ</b> Μη μεταφέρετε το εργαλείο κρατώντας το από το σωλήνα.		<b>▲ ΠΡΟΕΙΔΟΠΟΙΗΣΗ</b> Μη χρησιμοποιείτε κατεστραμμένους, λειωμένους ή φθαρμένους σωλήνες και προσαρτήματα.
	<b>▲ ΠΡΟΕΙΔΟΠΟΙΗΣΗ</b> Διατηρείτε το σώμα σας σε στάση ισορροπίας και σταθερό. Μην υπερβίνετε τη θέση ισορροπίας όταν λειτουργείτε αυτό το εργαλείο.		<b>▲ ΠΡΟΕΙΔΟΠΟΙΗΣΗ</b> Λειτουργείτε με Μέγιστη πίεση αέρος 90 psig (6.2 bar/620 kPa).		

## ΧΡΗΣΗ ΣΥΣΤΗΜΑΤΟΣ ΔΙΑΧΕΙΡΙΣΗΣ ΙΣΧΥΟΣ

### ▲ ΠΡΟΕΙΔΟΠΟΙΗΣΗ

Τα Αερόκλειδα δεν είναι μηχανισμοί ελέγχου ροπής στρέψης. Συνδεδηρες (Κοχλίες, Περικόχλια κ.λ.π) με ειδικές ανάγκες ροπής πρέπει να ελέγχονται με κατάλληλους μηχανισμούς μέτρησης ροπής μετά την τοποθέτηση τους με ένα αερόκλειδο.

Τα Μοντέλα Κρουστικών Κλειδών AW7500 έχουν ενσωματωμένο ένα σύστημα Διαχείρισης Ισχύος που επιτρέπει στον χειριστή να εκλέγει τέσσερις διαφορετικές ρυθμίσεις ισχύος. Αυτές οι ρυθμίσεις εκτείνονται από ελάχιστη παροχή ισχύος μέχρι την μέγιστη παροχή ισχύος μόνο στην εμπρόσθια περιστροφή. Το Αερόκλειδο λειτουργεί πάντα σε μέγιστη ισχύ στην ανάστροφη περιστροφή, ασχέτως της εκλογής επιπέδου παροχής ισχύος.

### ΣΥΣΤΗΜΑ ΔΙΑΧΕΙΡΙΣΗΣ ΙΣΧΥΟΣ ΜΟΝΤΕΛΑ AW7500



### ▲ ΠΡΟΕΙΔΟΠΟΙΗΣΗ

Οι τέσσερις ενδείκτες ρύθμισης ισχύος προοδευτικά αυξανόμενου μεγέθους στο πίσω μέρος του κελύφους, δύνανται αύξηση του επιπέδου ισχύος και είναι μόνο για αναφορά, ΔΕΝ προσδιορίζουν συγκεκριμένη παροχή ισχύος. Ο μικρότερος σε μέγεθος ενδείκτης προσδιορίζει ελάχιστη παροχή ισχύος, οι δύο ενδιάμεσοι ενδείκτες προσδιορίζουν μέσες παροχές ισχύος και ο μεγαλύτερος σε μέγεθος ενδείκτης προσδιορίζει μέγιστη παροχή ισχύος.

Η παρεχόμενη ισχύς μπορεί να ελατωθεί περαιτέρω στην εμπρόσθια ή στην ανάστροφη περιστροφή με την χρησιμοποίηση του μεταβλητού χειριστήριου. Συστήματα παροχής αέρα που δεν παρέχουν επαρκή πίεση αέρα επηρεάζουν την παρεχόμενη ισχύ σε κάθε ρύθμιση.



## ΘΕΣΗ ΕΡΓΑΛΕΙΟΥ ΣΕ ΛΕΙΤΟΥΡΓΙΑ

ΛΙΠΑΝΣΗ



Mac Tools Pneumatic



Χρησιμοποιείτε Mac Tools Pneumatic για συνηθισμένη (ρουτίνα) εξωτερική λίπανση του μηχανισμού κρούσης δια μέσου του Γρασσαδόρου στο Περιβλήμα της Σφύρας.

Χρησιμοποιείτε Mac Tools Pneumatic όταν αποσυναρμολογείτε και συναρμολογείτε τον μηχανισμό κρούσης.

Χρησιμοποιείτε πάντα ένα λιπαντήρα γραμμής αέρος με αυτά τα εργαλεία. Εμείς συνιστούμε την ακόλουθη Μονάδα Φίλτρου-Λιπαντήρα-Ρυθμιστή:

Για τις ΗΠΑ – No. C18-03-FKG0-28

Για Διεθνή – No. C16-C3-A29

ΣΗΜΕΙΩΣΗ

Μη μαρκάρετε οποιαδήποτε μη μεταλλική επιφάνεια αυτού του εργαλείου με κωδικούς αναγνώρισης του πελάτη. Τέτοιες ενέργειες μπορεί να βλάψουν την απόδοση του εργαλείου..

ΚΥΡΙΕΣ ΓΡΑΜΜΕΣ 3 ΦΟΡΕΣ ΤΟ ΜΕΓΕΘΟΣ ΤΗΣ ΕΙΣΑΓΩΓΗΣ ΑΕΡΟΣ ΣΤΟ ΕΡΓΑΛΕΙΟ

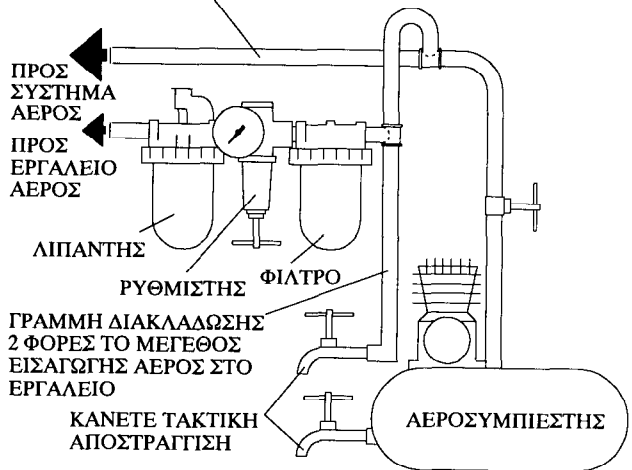

(Σχ. TPD905-1)

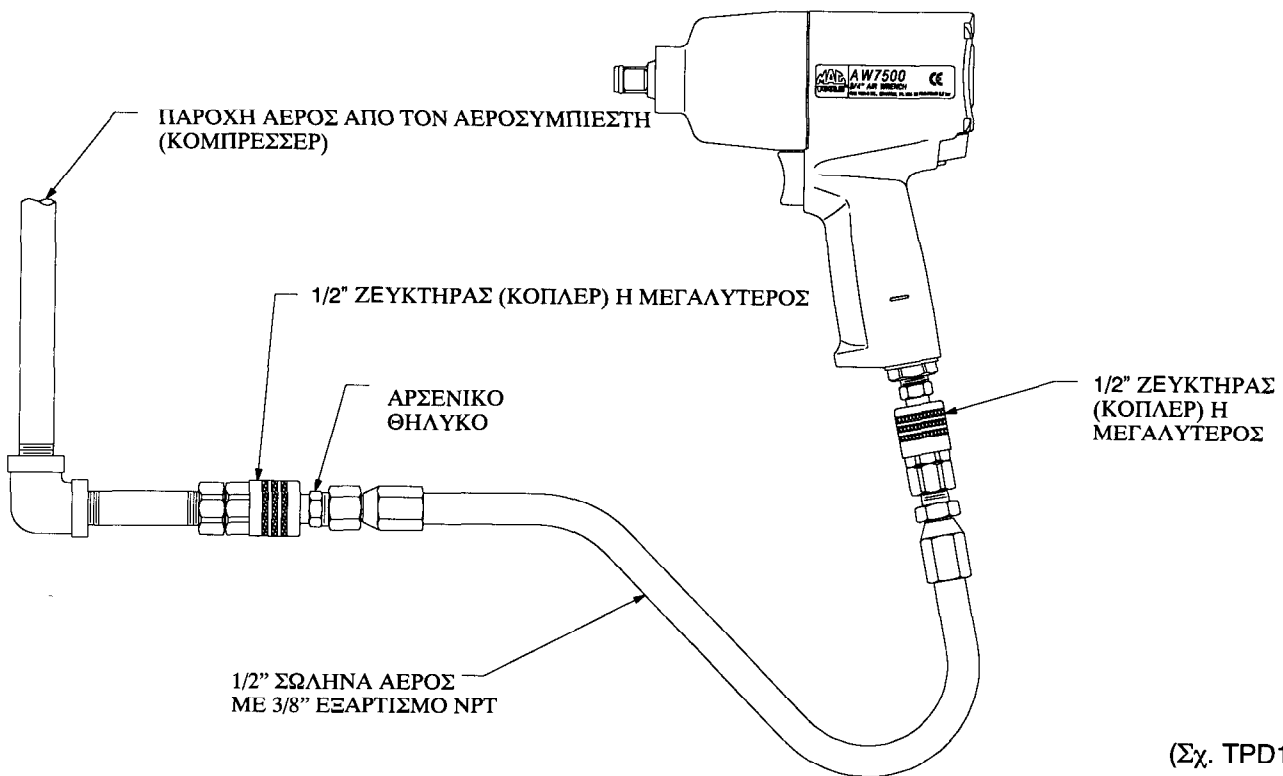

(Σχ. TPD1814)

## ΘΕΣΗ ΕΡΓΑΛΕΙΟΥ ΣΕ ΛΕΙΤΟΥΡΓΙΑ

### ΠΡΟΔΙΑΓΡΑΦΕΣ

Μοντέλο	Τύπος Λαβής	Οδηγός	Ελεύθερη Ταχύτητα	Κλίμακα Θορύβου σε ντεσιμπέλ	
				Περιστροφή ποδ. λιτ. (Nm)	Αναστροφή ποδ. λιτ. (Nm)
AW7500	χειρολαβή πιστολιού	3/4"	1.175	200-900 [1100 μεγ.] (271-1220 [1492 μεγ.])	200-900 [1200 μεγ.] (271-1220 [1627 μεγ.])

Μοντέλο	■Κλίμακα Θορύβου σε ντεσιμπέλ		Επίπεδο Δονήσεων m/s <sup>2</sup>
	Πίεση	Ισχύς	
AW7500	102,9	115,9	5,9

- Έχει δοκιμαστεί σύμφωνα με το PNEUROP PN8NTC1.2
- ◆ Δοκιμάστηκε σε ISO8662-7 φορτωμένο με πέδη τριβής σε 9 Στρ. Ανά Λεπτό



ΔΗΛΩΣΗ ΕΓΚΥΡΟΤΗΤΑΣ

Εμείς Mac Tools  
(όνομα κατασκευαστή)

Columbus, OHIO 43232 USA  
(διεύθυνση)

δηλώνουμε με τη δική μας ευθύνη ότι τα παρακάτω κατασκευάσματα,

Μοντέλα AW7500  
Αερόκλειδα Υπεριοχυρά Για Εργασίες Επί Τροχοφόρων

με τα οποία σχετίζεται αυτή η δήλωση συμβιβάζονται με τις παρακάτω συστάσεις

98/37/EK και διευκρινήσεις.

Δια χρησιμοποίησης των επόμενων Τυπικών Αρχών: IS08662, PNEUROP PN8NTC1

Περίοδος Αριθμού Σειράς (2000 → ) A00H XXXXX →

*Bill Mark*

Bill Mark  
Όνομα και υπογραφή εξουσιοδοτημένων προσώπων

Σεπτέμβριος, 2000  
Ημερομηνία

**ΠΡΟΣΟΧΗ**

**ΦΥΛΑΞΤΕ ΑΥΤΕΣ ΤΙΣ ΟΔΗΓΙΕΣ. ΜΗΝ ΤΙΣ ΚΑΤΑΣΤΡΕΨΕΤΕ.**

Όταν η προβλεπόμενη περίοδος κανονικής ζωής του εργαλείου έχει λήξει, συνιστάται η αποσυναρμολόγηση του εργαλείου, η απολίπανση και ο διαχωρισμός των αντλλακτικών κατά υλικό για να μπορέσουν να ανακυκλωθούν.