

OPERATION AND MAINTENANCE MANUAL

33 MA SERIES AIR MOTORS (REVERSIBLE, FLANGE MOUNTED)

MODEL CODE/COM.NO.	FREESPEED (rpm)	MAX.POWER (HP)	TORQUE AT MAXPOWER (ft.lbs)	STALL TORQUE (ft.lbs)
33MA-220 185A-B/04664827	220	0.72	34.4	48.5
33MA-405 185B-B/04664835	425	0.74	18.3	26.6
33MA-720 185C-B/04664843	750	0.75	10.5	14.7



WARNING

READ THIS MANUAL CAREFULLY BEFORE INSTALLING,
OPERATING OR SERVICING THIS EQUIPMENT.

IMPORTANT INSTRUCTIONS

- Always operate, inspect and maintain this tool in accordance with American National Standards Institute Safety Code for Portable Air Tools (ANSI B186.1) and any other applicable safety codes and regulations.
- For safety, top performance and maximum durability of parts, operate this tool at 6.3 Kg/cm² (90 psig) maximum air pressure.
- Use 1/2" bore hose pipe



WARNING

- Always turn off the air supply and disconnect the air supply hose before installing, removing or adjusting any accessory on this tool.
- The use of other than genuine IR-Wadco parts may result in safety hazards, decreased tool performance and increased maintenance costs and may invalidate all warranty claims.

For parts and service information, contact your local ARO distributor, or the Customer Service Dept. of the Ingersoll - Rand Distribution Center, White House, TN at PH : (615) 672 - 0801, Fax : (615) 672 - 0801

INGERSOLL-RAND WADCO TOOLS LTD.

WARNING LABEL IDENTIFICATION

▲ WARNING

FAILURE TO OBSERVE THE FOLLOWING WARNINGS COULD RESULT IN INJURY.

	<p>▲ WARNING</p> <p>Always wear eye protection when operating or performing maintenance on this tool.</p>
---	--

	<p>▲ WARNING</p> <p>Always wear hearing protection when operating this tool.</p>
---	---

	<p>▲ WARNING</p> <p>Always turn off the air supply and disconnect the air supply hose before installing, removing or adjusting any accessory on this tool, or before performing any maintenance on this tool.</p>
--	--

	<p>▲ WARNING</p> <p>Air powered tools can vibrate in use. Vibration, repetitive motions or uncomfortable positions may be harmful to your hands and arms. Stop using any tool if discomfort, tingling feeling or pain occurs. Seek medical advice before resuming use.</p>
---	---

	<p>▲ WARNING</p> <p>Do not carry the tool by the hose.</p>
---	---

	<p>▲ WARNING</p> <p>Do not use damaged, frayed or deteriorated air hoses and fittings.</p>
--	---

	<p>▲ WARNING</p> <p>Keep body stance balanced and firm. Do not overreach when operating this tool.</p>
---	---

	<p>▲ WARNING</p> <p>Operate at 90 psig (6.2 bar/620 kPa) Maximum air pressure.</p>
---	---

OPERATION

For optimum performance, the air source and supply lines must be capable of maintaining 90 psig (6.2 bar/620 kPa) air pressure at the Motor. 1/2" (12mm) diameter or larger hose is necessary for ample air flow to each Motor.

Reversible Motors require the use of a 4-way valve, or two 3-way valves in the supply in the supply line because the reverse air inlet port becomes an auxiliary port when the Motor operates in forward rotation. In reverse, the forward inlet becomes the auxiliary exhaust port.

An example of each method is diagrammed in the following illustration.

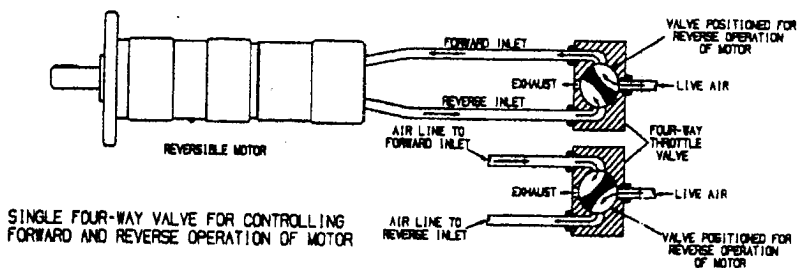

Single Four-Way Valve for Controlling Forward and Reverse Operation of Motor

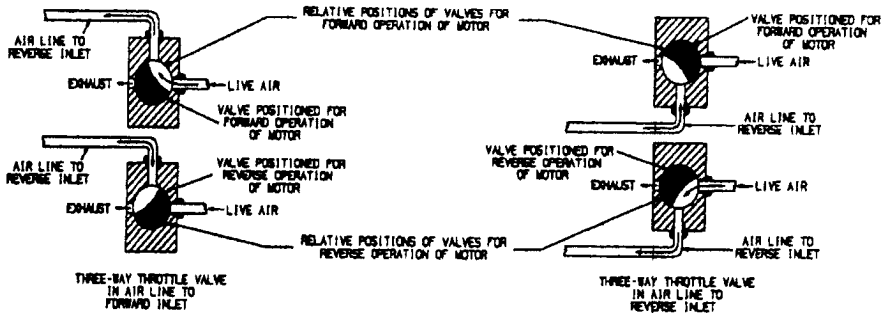

Two Three-Way Valves for Controlling Forward and Reverse Operation of Motor

PLACING TOOL IN SERVICE

LUBRICATION

Oil : Ingersoll - Rand No. 10 Lubricant

Grease : Ingersoll - Rand No. 28 Lubricant

We recommend the use of an air line lubricator in the air supply line. Attach the unit as close to the tool as practical. After each forty hours of operation, or as experience indicates, introduce 1.5cc of the recommended grease. Do not grease excessively. Too much grease in the Gear Case will cause heating.

Grease leakage from the Spindle end is also an indication that an excessive amount of grease has accumulated within the Gear Box.

Whenever the Gear end of the Motor is disassembled, lubricate the gear train.

For 33 MA Series Air Motors work approximately 25 cc of the recommended grease into the gear train and around the Bearings and on the Spindle.

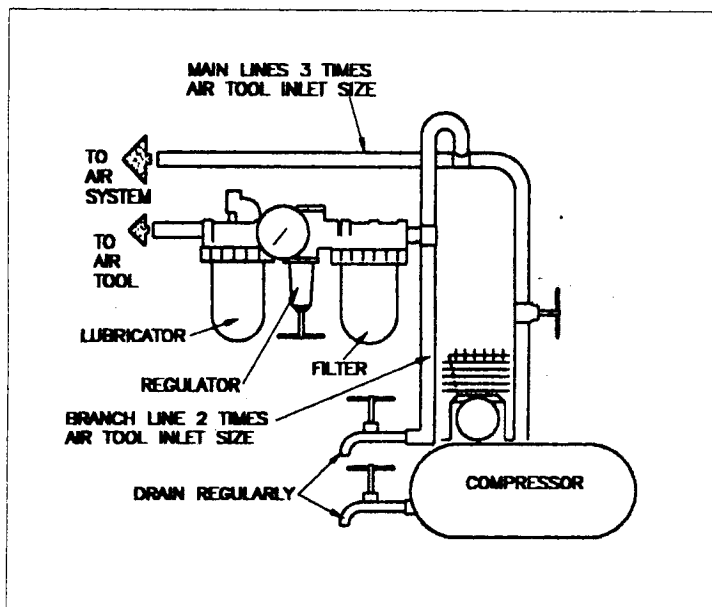

Always use an air line lubricator with this tool. A filter regulator and lubricator (FRL) unit is recommended.

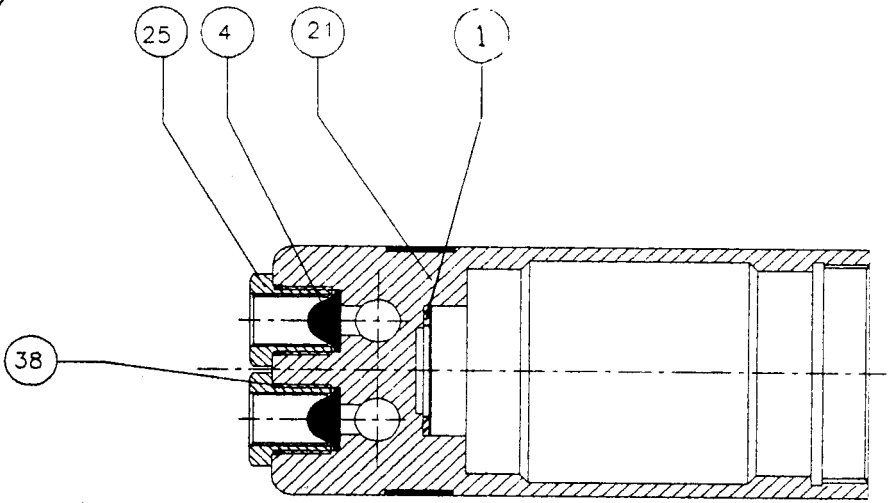

ROTOR HOUSING ASSY.

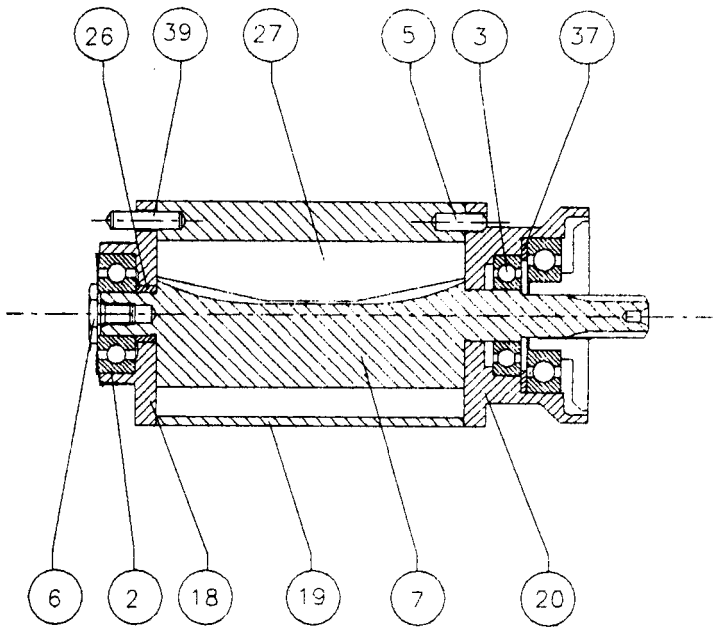

MOTOR ASSY.

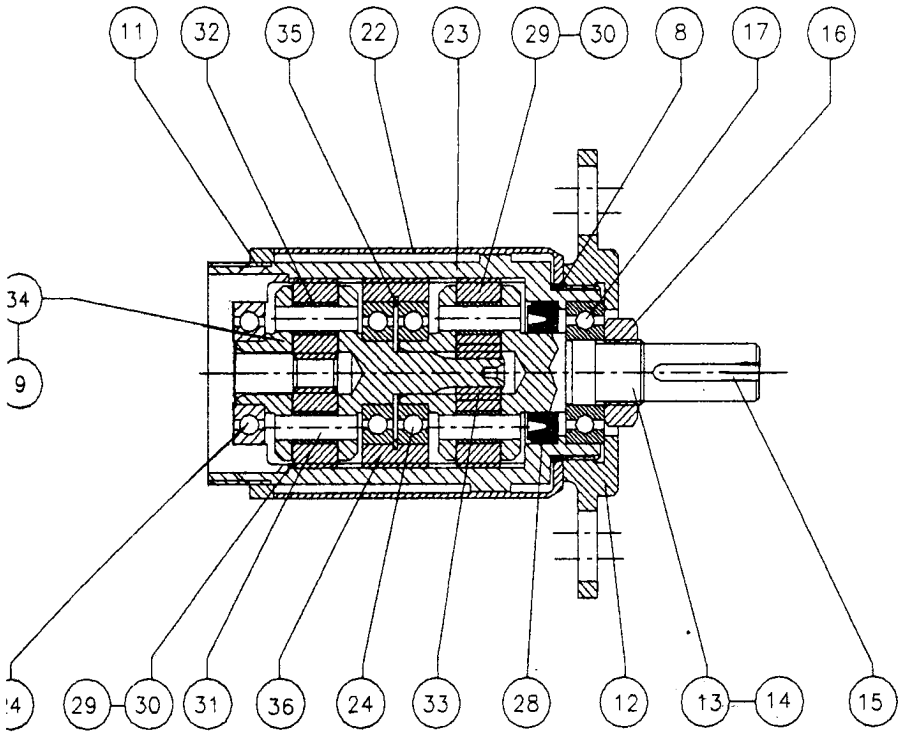

GEAR BOX ASSY.

BILL OF MATERIAL

33 MA - *

Sr.No.	DESCRIPTION	*220	*406	*720
1	SPRING WASHER	1	1	1
2	BEARING	1	1	1
3	BEARING	1	1	1
4	STRAINER	2	2	2
5	ROLL PIN	1	1	1
6	CLAMP SCREW	1	1	1
7	ROTOR	1	1	1
8	'O' RING	1	1	1
9	DRIVE SHAFT	1	1	0
10	NAME PLATE	1	1	1
11	LOCK RING	1	1	1
12	FLANGE	1	1	1
13	SPINDLE	1	0	0
14	SPINDLE	0	1	1
15	KEY	1	1	1
16	NUT	1	1	1
17	BEARING	1	1	1
18	UPPER CENTRE PLATE	1	1	1
19	CYLINDER BUSHING	1	1	1
20	LOWER CENTRE PLATE	1	1	1
21	ROTOR HOUSING	1	1	1
22	MUFFLER	1	1	1
23	GEAR CASE	1	1	1
24	BEARING	3	3	3
25	REDUCER	2	2	2
26	SPACER	1	1	1
27	ROTOR BLADE	5	5	5
28	OIL SEAL	1	1	1
29	IDLER GEAR (19T)	6	3	0
30	IDLER GEAR (16 T)	0	4	8
31	IDLER GEAR PIN	6	7	8
32	NEEDLE ROLLER	90	105	120
33	SUNWHEEL	0	1	2
34	DRIVE SHAFT	0	0	1
35	INTERNAL CIRCLIP	1	1	1
36	BEARING CARRER	1	1	1
37	SPACER	1	1	1
38	'O' RING	2	2	2
39	ROLL PIN	1	1	1

**MINOR TUNE - UP KIT
FOR 33 MA SERIES
AIR MOTORS
P/NO. TK 1010**

Sr. NO.	Part Name	Qty
4	Strainer	2
5	Roll Pin	1
8	O-Ring	1
15	Key	1
27	Rotor Blade	5
28	Oil Seal	1
38	O-Ring	2
39	Roll Pin	1

**MAJOR TUNE - UP KIT
FOR 33MA SERIES
AIR MOTORS**

Sr. No.	Part Name	Quantity reqd. for each Models of 33 MA Series		
		220	405	720
1	Spring Washer	1	1	1
2	Bearing	1	1	1
3	Bearing	1	1	1
4	Strainer	4	4	4
5	Roll Pin	2	2	2
8	O-Ring	2	2	2
15	Key	2	2	2
17	Bearing	1	1	1
24	Bearing	3	3	3
26	Spacer	1	1	1
27	Rotor Blade	10	10	10
28	Oil Seal	2	2	2
29	Idler Gear (19T)	6	3	0
30	Idler Gear (16T)	0	4	8
31	Idler Gear Pin	6	7	8
32	Needle Roller	90	105	120
33	Sun Wheel	0	1	2
35	Internal Circlip	1	1	1
37	Spacer	1	1	1
38	O-Ring	4	4	4
39	Roll Pin	2	2	2
Major Tune - Up Kit P/N		TK5047	TK5048	TK5049

DISASSEMBLY

General Instructions



WARNING

1. Always disconnect the air supply before doing any maintenance.
2. Always use protective eye wear when performing maintenance on a tool or when operating a tool.
3. Do not disassemble the tool any further than necessary to replace or repair damaged parts.
4. Do not disassemble the Motor unless you have a complete set of new gaskets and 'O' rings for replacement.
5. Do not remove any part which is a press fit in or on a subassembly unless the removal of that part is necessary for repair or replacement.
6. Whenever grasping a tool or part in a vice, always use leather - covered or copper - covered vice jaws to protect the surface of the part and help prevent distortion. This is particularly true of threaded members and housings.
7. The modular construction of 33 series motors permits selective disassembly whereby gearing can be separated from the power unit and disassembled without removing the motor from the Rotor Housing, or the motor can be removed and disassembled without removing the gear train from the gear chambers. Because of the modular construction, the steps in the following disassembly procedures can be sequentially changed to meet the particular situation.

Disassembly of Gear Box

1. Hold the tool in a vice clamping it on the Rotor Housing (21).
2. Loosen the Flange (12) (Left hand thread).
3. Take out 'O' Ring (8) and Muffler (22).
4. Holding the Spindle (13 / 14) stationary using an allen key 3/16" A/F, remove the Nut (16) with a Spanner 19 mm A/F.
5. Slide the Lock Ring (11) onto the Gear Case (23) so that it gets disengaged from the Rotor Housing (21)
6. Use a Spanner 44 mm A/F to loosen the Gear Case (23) from the Rotor Housing. The Motor assembly will also come out along with the Gear Case Assembly.
7. Tap end of Spindle (13 / 14) using a soft hammer. The Spindle Assembly, Bearing Carrier Assy., Drive Shaft Assy. and Motor Assy. will come out.
8. Using a wedge shaped tool and hammer, separate the above assemblies.
9. Hammer out the Idler Gear Pin (31) from the Spindle (13 / 14) and Drive Shafts (9 / 34), so that Idler Gears (29 / 30) and Sun Wheel (33) can be taken out.
10. If any of the Bearing needs to be replaced, take it out from the assembly.

Disassembly of the Motor

1. Loosen the Clamp Screw (6) using a 3/8" A/F. spanner.
2. Tap drive end of Rotor (7) with a soft hammer, motor will come apart.
3. If the Upper Centre Plate bearing (2) needs to be replaced, press it out from the Upper Centre Plate (18).
4. Remove the Roll Pins (5 / 39) if required only.
5. Lift off the Cylinder Bushing (19).
6. Remove the Rotor Blades (27).
7. If the Lower Centre Plate Bearing (3) needs to be replaced, press it out from Lower Centre Plate (20).

ASSEMBLY

General Instructions



1. Always use protective eye wear when performing maintenance on a tool or operating a tool.
2. Always press on the inner ring of a ball - type bearing when installing the bearing on a shaft.
3. Always press on the outer ring of a ball - type bearing when installing the bearing in a bearing recess.
4. Check every bearing for roughness. If an open bearing must be cleaned, wash it thoroughly in clean solvent and dry with a clean cloth. Work grease thoroughly into every open bearing before installation. Sealed or shielded bearings should never be cleaned.
5. Except for bearings, always clean every part and wipe every part with a thin film of oil before installation.
6. When grasping a Motor or one of its parts in a vice, always use leather or copper vice jaw covers to protect the surface of the part and reduce the likelihood of damage. This is particularly important when clamping threaded members, shafts with splines etc.
7. Apply ' O ' Ring lubricant to each ' O ' Ring before assembly.

Assembly of Motor & Housing

1. Slide the Spacer (26) over the unsplined end of the Rotor (7).
2. Press the Upper Centre Plate (18) and the Bearing (2) onto the Rotor Shaft.
3. Tighten the Clamp Screw (6) on to the Bearing (2) using a 3/8" A/F spanner.

NOTE :- The clearance between the Upper Centre Plate (18) and the Rotor (7) is critical.

This should be set to 0.04/0.06 mm. using a feeler gauge or shim, (If required the Spacer (26) can be ground from one side).

4. Replace the Roll Pins (5 / 39) into the Cylinder Bushing (19).

NOTE :- The shorter Roll Pin (5) should go into the deeper hole and vice versa.

5. Place the Cylinder Bushing (19) over the Rotor (7), aligning the Roll Pin (39) in the Cylinder Bushing (19) with the dowel hole in the Upper Centre Plate (18).

6. Apply a film of light oil to each Rotor Blade (27) and insert a Rotor Blade, straight edge out, into each vane slot in the Rotor (7). If new Rotor Blades are required, replace the entire set.

7. Grasp shoulder of Upper Centre Plate (18) in a vice having leather covered jaw.

8. Check the Lower Centre Plate (20) for wear. If there is excessive wear replace with a new one.

9. Press the Lower Centre Plate (20) and Bearing (3) onto the Rotor Shaft aligning the Roll Pin (5) in the Cylinder Bushing (19) with the dowel hole in the Lower Centre Plate (20).

10. Replace Spacer (37) next to Lower Centre Plate Bearing (3).

11. Hold Rotor Housing (21) in a vice so that the open side is at the top.

12. Insert the Spring Washer (1), the Motor Assembly into the Rotor Housing aligning the Roll Pin in the Upper Centre Plate (18) and the blind hole in the Rotor Housing.

13. Clean the face of the Reducers (25) and Strainers (4) in a suitable cleaning solution before assembling into the tool. Assemble Strainer (4) in the Reducer (25). Also assemble ' O ' Ring (38).

14. Using a wrench tighten the Reducer (25) onto the Rotor Housing.

Assembly of Gear Box

1. Place the shoulder of the Drive Shaft (9 / 34) / Spindle (13 / 14) on the vice jaws.

2. Place the Idler Gear (29 / 30) fitted with *Needle Rollers* (32) inside the slot of the Drive Shaft (9 / 34) / Spindle (13 / 14).

IMP :- In models where Sun Wheels (33) are to be used introduce it before assembly of Idler Gears.

3. Press the Idler Gear Pin (31) inside.

4. Install Internal Circlip (35) inside the Bearing Carrier (36) using Circlip pliers.

5. Lubricate Bearings (24) with the recommended grease and install in the Bearing Carrier (36).

6. Assemble Oil Seal (28) inside the Gear Case (23) so that the concave face is facing the wide mouthed end of insert.

7. Insert the unkeyed end of Spindle (13 / 14) into the Bearing Carrier Assembly.

8. Press the Drive Shaft Assembly into the Bearing (24) of the Bearing Carrier Assembly from its other side.

9. Coat inside of Gear Case (23) with the recommended grease.

10. Insert the whole Assembly from inside the Gear Case (23) keyed end of Spindle first.
11. Lubricate Bearing (17) with the recommended grease. Support other end of Spindle (13 / 14) from inside the Gear Case. Install Bearing (17) in the recess in the Gear Case (23) pressing it on the outer race.
12. Holding the Spindle (13 / 14) from rotating tighten the nut with Spanner 19 mm A/F.
13. Lubricate Bearing (24) with recommended grease. Install it on the Drive Shaft (9 / 34) pressing the inner race of the bearing.
14. Hold the Rotor Housing Assembly on the A/ F in a vice.
15. Replace the Lock Ring (11) over the Gear Case (23).
16. Tighten the Gear Case Assembly using a Spanner 44 mm A/F on to the Rotor Housing Assembly. When it is almost fully tight slide the Lock Ring (11) so that it's teeth gets engaged with the slots of the Rotor Housing (21).
17. Assemble the Muffler (22) with the large diameter end going first.
18. Coat 'O' Ring lubricant over the 'O' Ring (8) and install it in the groove on the Gear Case (23).
19. Tighten the Flange (12) on to the Gear Case (23) (Left hand thread). For torque value and other details refer Page No. 14

TROUBLE SHOOTING GUIDE

Trouble	Probable Cause	Solution
Motor will not operate	Rotor shaft and idler gears binding due to improper installation	Using an allen key, turn the output shaft. If the force to be applied is very great considering the gear ratio, the gearing is improperly installed and must be reassembled. See Paragraphs .for assembly of the gearing
	Spline in shaft of drive shaft and idler gears binding due to improper installation	Solution same as above
Loss of power	Low air pressure at motor	Check air supply. For top performance, the air pressure, must be 90 psig (6.3 Kg/cm ²)at the inlet
	Worn Vanes	Install a new Set of Vanes
	Inadequate motor lubrication	Check air line lubricator. Refer page 4 for lubrication specifications
	Worn or damaged parts	Disassemble the motor and examine parts. Replace any worn or damaged parts
Motor heats up	Inadequate lubrication	Refer to Lubrication Section on Page 4
Gear Box heat up beyond normal increase	Improper lubrication	Refer to Lubrication Section on Page 4
Grease leakage	Too much grease in the gear box	Refer to Lubrication Section on Page 4

Special Note :

Flanges (12) of all reversible models are to be tightened to about double the stall torque value of the respective air motors. This can be done using a torque wrench of 3/4" SQ DRIVE - 200 ft. lbs capacity and a Coupling (M2360). This arrangement is shown diagrammatically in the following sketch.

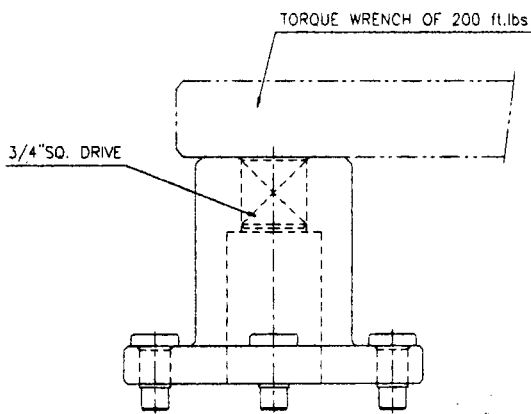

M 2360