

OPERATION AND MAINTENANCE MANUAL

for

MODELS KK5B546 AND KK5B550

STATIONARY AIR MOTORS

Always operate, inspect and maintain this tool in accordance with American National Standards Institute Safety Code for Portable Air Tools (ANSI B186.1) and any other applicable safety codes and regulations.

FOR TOP PERFORMANCE AND MAXIMUM DURABILITY OF PARTS, OPERATE THIS MOTOR AT 90 psig (6.2 bar/620 kPa) AIR PRESSURE WITH 2" (50 mm) AIR SUPPLY HOSE.

▲WARNING

Always turn off the air supply and disconnect the air supply hose before installing, removing or adjusting any accessory on this tool, or before performing any maintenance on this tool. Failure to do so could result in injury.

NOTICE

Control Valves

The K5B PILOT and K5B MANUAL Control Valves cause a performance reduction of 20% with the same starting and stall torque. This reduction of horsepower and free speed is the result of the Valve's restriction of maximum air flow.

K5B-K269 Pendant Control and UWD-A686 Panel Mount Control

These controllers give good control with up to 100 feet of control line length. Control response deteriorates as the air lines exceed the limiting length. We recommend the installation of Ingersoll-Rand MR-939 Quick Exhaust Valves in the control lines after 50 feet of length and each 50 feet of length thereafter. These Quick Exhaust Valves can be used with up to 3/16" to 1/4" i.d. air control hose.

LUBRICATION

NOTICE

The Motors are shipped less oil and must be refilled prior to operation of the motor. Shut off air supply and add 4 oz. (1/4 cup) motor oil to air hose before running motor. Air supply to the motor must be filtered and lubricated at all times or damage to the Motor will result.

Filling the Motor with oil:

1. Motors are shipped with cans of I-R motor oil, or the following oil can be substituted:
 Below 32° F (0° C): SAE 10W or Dexron ATF
 32° F to 80° F (26° C): SAE 20W or Dexron ATF
 Above 80° F (26° C): SAE 30W or Dexron ATF
 (Motors use approximately 64 oz.)
2. Maintain Motor in a horizontal position.
3. Remove Vent Cap Assembly (11) and Plug (4).
4. While pouring oil through the fill hole (11), slowly rotate the Motor at less than 50 RPM.
5. Motor case is full when oil begins to flow out of hole from which Plug(4) was removed.
6. Reinstall Plug and Vent Cap Assembly.

**Refer All Communications to the Nearest
Ingersoll-Rand Office or Distributor.**

© Ingersoll-Rand Company 1991

Printed in U.S.A.

INGERSOLL-RAND®
AIR MOTORS

Oil Level Checks

Check oil levels at the following conditions:

1. **At temperatures above 32° F (0° C):** After the Motor has been off for several hours or overnight, loosen the Drain Plug (2) located at the bottom of motor case and allow the accumulated water to drain out.
2. **At temperatures below 32° F (0° C):** Allow the Motor to remain off long enough for the water to separate from the oil but not long enough for it to freeze. The actual ambient air temperatures and oil temperature after shut-down will determine how long this will take. Drain the water and replenish oil as above.

NOTICE

Should this procedure be impractical, drain the entire contents from the motor case immediately after motor operation ceases. The Motor may need to be cranked slowly (at less than 50 rpm) for a few revolutions to push the oil out of the two lower cylinders.

NOTICE

If the Motor is not be refilled at this time, tag the Motor and Throttle to indicate that it should not be used prior to refilling. Failure to do this will result in damage to the motor.

NOTICE

If motor case is not drained in temperatures below freezing, water may eventually accumulate and cause the Motor to freeze so that it will not operate.

3. **After every eight (8) hours of operation** inject two or three pumps of #2 cup grease from a hand grease gun into Grease Fitting (38).

Air Supply Lines

Air motors require approximately 30 cfm of free air at 100 psig (6.8 bar) to generate one (1) horsepower. The KK5B546 and KK5B550 will require approximately 720 cfm for continuous operation at maximum horsepower. To achieve this performance, an air line of 2" (51 mm) or greater in diameter should be used. The supply air must be clean, free of water and moisture and **must be lubricated**. Therefore, the air supply system must include an inlet filter of 20 micron filtration, a moisture trap and a line oiler. The air line oiler should deliver 10–15 drops per minute of SAE 10W Oil or Dexron ATF.

NOTICE

The air line oiler is not a substitute for the motor case oil described in the lubrication section. Make sure that there is enough oil in the lubricator prior to each use for proper Rotary Valve lubrication.

INSTALLATION

General Information

The Motor must be mounted in a horizontal position with the throttle handle straight up. If the Motor is to be mounted at an angle of 10° or more off horizontal, poor internal lubrication will result. Consult the factory for special instructions. Flange mounted Motors can be mounted using either of the following two methods:

- Method 1.** Provide a mounting with a close fit on the 13–3/8" (339.7mm) reference pilot diameter on the Mounting Flange Cover (46). Fasten with Capscrews (49), Lock Washers (51) and Nuts (50).
- Method 2.** Use the 16–1/8" (409.6mm) reference outside diameter of the Mounting Flange Cover. Fasten with the Capscrews, Lock Washers and Nuts.

For either method, the following general information applies:

1. It is necessary to provide a bearing for the outer end of the motor shaft pinion or shaft extension. Locate it as far from the Motor as practical and be certain that it is properly aligned.
2. Do not make shaft extensions a tight fit in the broached spline of the Crank. An outboard bearing cannot be perfectly aligned with the crank bearings; therefore, the splined fit must serve to a limited extent as a flexible coupling.
3. The motor shaft must be supported in such a manner that no end thrust will be transferred to the crank.
4. Consult the factory if more detail is needed.
5. The spline end of the motor output is not sealed. Therefore, a seal must be provided on the mounting around the shaft to prevent loss of motor oil.

TOP VIEWS

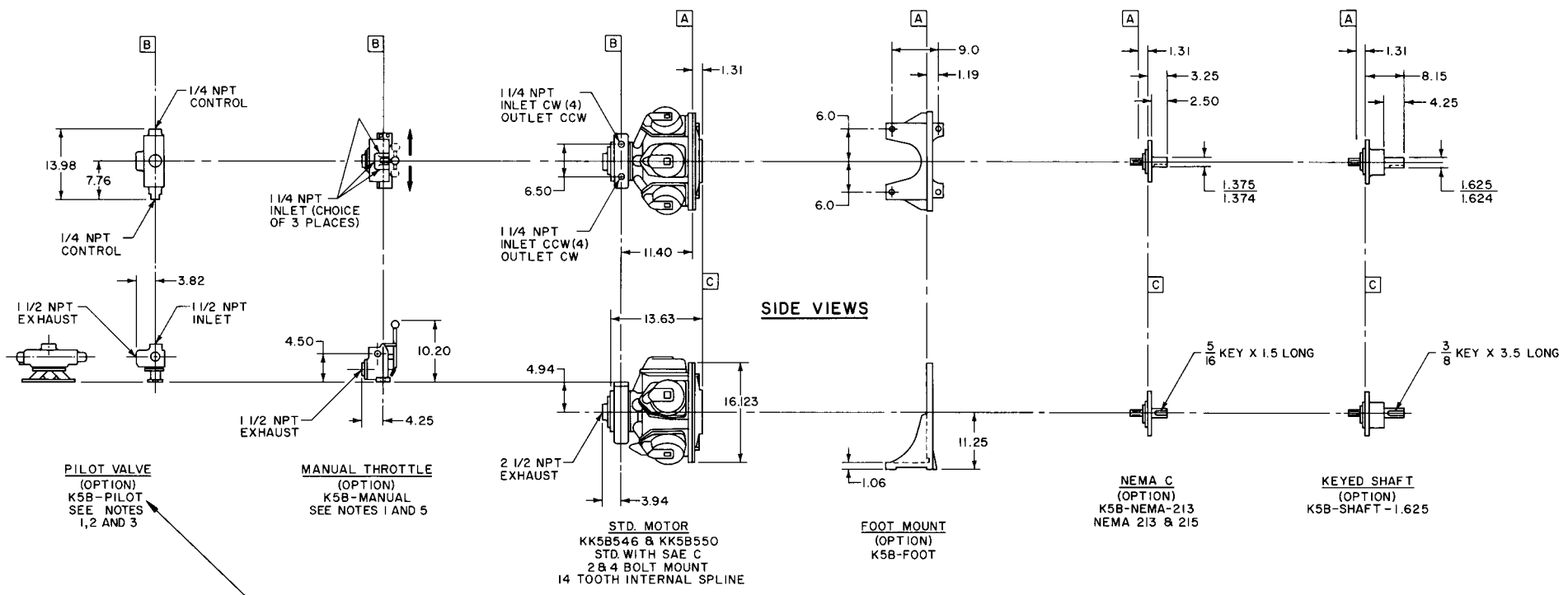

3

PILOT VALVE
(OPTION)
K5B-PILOT
SEE NOTES 1, 2 AND 3

MANUAL THROTTLE
(OPTION)
K5B-MANUAL
SEE NOTES 1 AND 5

PILOT CONTROL
(OPTIONS)

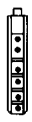

ACCU-TROL™
SEE INGERSOLL-RAND
BEEBE MAT'L HANDLING
CATALOG FOR DETAILS



PENDENT
K5B-K269
(INCLUDES FITTINGS)
3/16 ID HOSE MUST BE
PURCHASED SEPARATELY
BH3A-SPECIFY
LENGTH IN FEET
3 HOSES REQ'D.
SEE NOTES 2 & 3

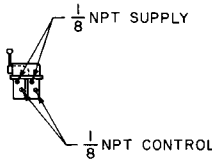

PANEL MOUNT
UWD-A686
HOSE-FITTINGS-TUBING
NOT INCLUDED
3/16 TO 1/4 RECOMMENDED
3 LINES REQ'D.
SEE NOTES 2 & 3

- 1) PERFORMANCE REDUCTION OF 20% - SAME STARTING AND STALL TORQUE BUT REDUCED HORSEPOWER AND FREE SPEED AS VALVING RESTRICTS MAX. AIR FLOW
- 2) FOR CONTROL LINE LENGTHS GREATER THAN 50 FT. AND FOR EVERY 50 FT. THEREAFTER INSTALL TWO QUICK EXHAUST VALVES IN CONTROL LINES: MLK-A939 FOR 3/16 ID HOSE OR MR-939 (3/8 NPT) FOR 1/4 ID LINES
- 3) AIR PILOT CONTROLS GIVE GOOD CONTROL UP TO 100 FT. AS THE CONTROL LINES LENGTHEN THE CONTROL RESPONSE DETERIORATES. ROUTE CONTROL LINES IN THE SHORTEST MANOR PRACTICAL
- 4) CW - CLOCKWISE ROTATION OF MOTOR LOOKING AT OUTPUT SHAFT OR SPLINE
CCW - COUNTERCLOCKWISE ROTATION OF MOTOR LOOKING AT OUTPUT SHAFT OR SPLINE
- 5) THE MANUAL THROTTLE MAY BE REMOTELY MOUNTED UP TO 30 FT. AWAY USING EITHER 1 1/2 ID HOSE OR PIPE

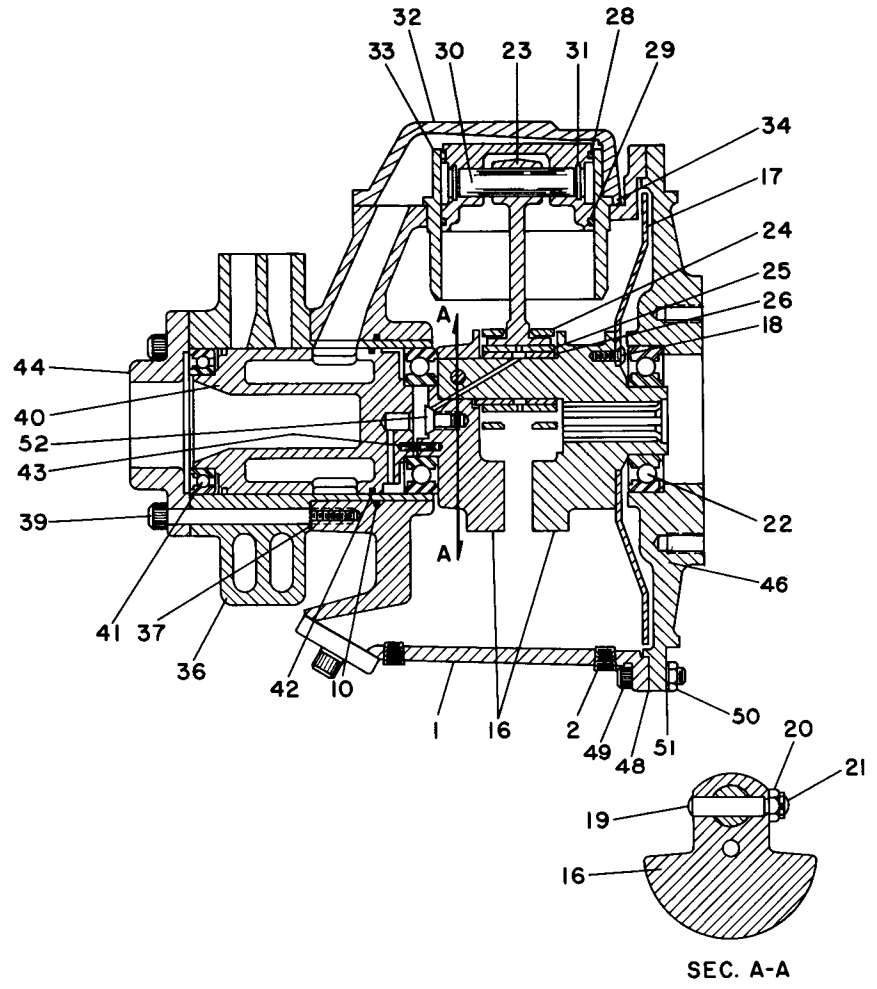
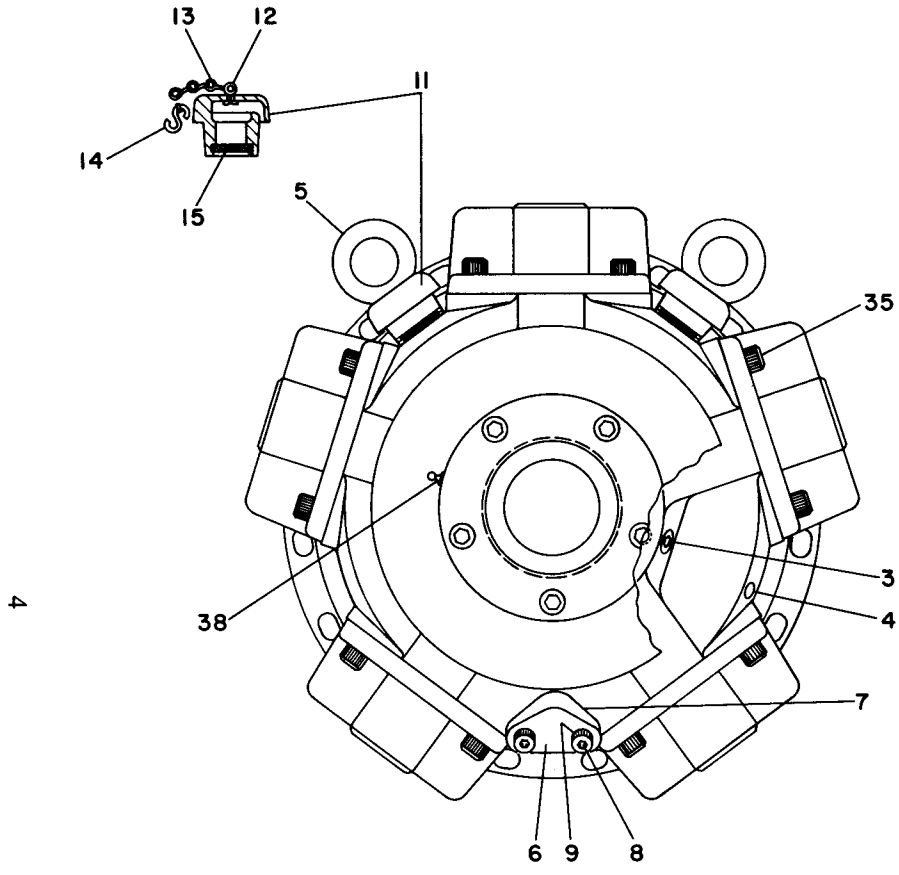

(Dwg. TPA1300)

PART NUMBER FOR ORDERING



PART NUMBER FOR ORDERING



		KK5B546	KK5B550			KK5B546	KK5B550
1	Motor Housing	K5B-501	K5B-501	• 26	Sleeve	K5B-519	K5B-519
2	Pipe Plug (3/8") (2)	GA57-95	GA57-95		Piston Assembly (5)	K5B-A513-47	K5B-A513A-50
3	Pipe Plug (1/4")	R0H-377	R0H-377	• 28	Compression Ring	K5B-337-47	KU-337
4	Pipe Plug (1/8")	TC-368	TC-368	• 29	Oil Ring	K5B-338-47	KU-338
5	Eye Bolt (2)	KU-888	KU-888	30	Wrist Pin	HU-514A	251A0223A
6	Cover Plate	K5B-1001	K5B-1001	31	Retainer Ring (2)	902A45-632	————
• 7	Gasket	K5B-1002	K5B-1002		Cylinder Assembly (5)	K5B-A505-47	251P2830A
8	Cap Screw (2)	119A2A202	119A2A202	32	Cylinder Head	K5B-H505	————
9	Lock Washer (2)	D02-321	D02-321	33	Cylinder Liner	K5B-L505-47	————
• 10	O-ring	20A11CM248	20A11CM248	• 34	Head Gasket (5)	K5B-507	K5B-507
11	Vent Cap Assembly (2)	K5B-A303	K5B-A303	35	Cap Screw (20)	119A2A251	119A2A251
12	Cotter Pin	D02-893	D02-893	36	Rotary Valve Housing	K5B-545	K5B-545
13	Chain	D02-891	D02-891	• 37	Gasket (2)	K5B-928	K5B-928
14	S-hook	D02-421	D02-421	38	Grease Fitting	23-188	23-188
15	Screen	K5B-889	K5B-889	39	Cap Screw (5)	119A2A267	119A2A267
*	Nameplate	K5B-301	K5B-301	40	Rotary Valve	K5B-526	K5B-526
*	Drive Screw (4)	R4K-302	R4K-302	• 41	Bearing	K5B-97	K5B-97
*	Caution Tag	K5B-113	K5B-113	• 42	Seal Ring	K5B-607	K5B-606
	Crank Assembly	KK5B-A516	KK5B-A516	43	Timing Pin	WF171-15	WF171-15
16	Crank	KK5B-516	KK5B-516	44	Exhaust Flange	KK5B-276M	KK5B-276M
17	Oil Slinger	K5B-540	K5B-540	46	Flange Mount	K5B276-SAE	K5B276-SAE
18	Button Head Screw (5)	K5B-541	K5B-541	• 48	Gasket	K5B-592	K5B-592
19	Lock Pin	HU-520	HU-520	49	Cap Screw (10)	119A2A254	119A2A254
20	Pin Nut	D02-394	D02-394	50	Nut (10)	215-182	215-182
21	Cotter Pin	D02-524	D02-524	51	Lock Washer (10)	D10-322	D10-322
• 22	Crank Bearing (2)	K5B-518	K5B-518	52	Flat Head Screw	139A2A266	139A2A266
23	Connecting Rod (5)	K5B-509	K5B-509				
• 24	Connecting Rod Ring	K5B-510	K5B-510				
• 25	Connecting Rod Bushing	K5B-511	K5B-511				

* Not illustrated.

• To keep downtime to a minimum, it is desirable to have on hand certain repair parts. We recommend that you stock one (pair or set) of each part indicated by a bullet (•) for every four tools in service.

MAINTENANCE

⚠ WARNING

Always turn off the air supply and disconnect the air supply hose before installing, removing or adjusting any accessory on this tool, or before performing any maintenance on this tool. Failure to do so could result in injury.

Models KK5B546 and KK5B550 Air Motors are reciprocating, radial 5 piston motors that use compressed air for a power source up to 110 psig maximum (7.5 bar). They have infinite variable speeds, develop maximum torque at low rpm and can be stalled–started–stopped and reversed without damage. Air motor performance characteristics can be preset to a maximum level with a commercially adjustable pressure regulator and controlled with a spring loaded manual throttle valve. The throttle can be ordered mounted on the motor or as a separate, remotely mounted universal type valve used for remote control operation.

DISASSEMBLY

Motor

NOTICE

Refer to drawing on page 4 for parts location.

⚠ WARNING

Shut off, bleed down and disconnect the air supply line before performing any maintenance or disassembly procedures.

1. Drain the motor oil from the motor case by removing Plug (2).

⚠ WARNING

The Motor weighs approximately 260 pounds (118 kgs). Provide adequate support before removing Mounting Cap screws (49).

2. Remove Cap Screws.
3. Remove Cap Screws (39) from the Exhaust Flange (44). Remove the Rotary Valve Housing (36) by pulling it out of the Motor Housing (1) as an assembly with the Exhaust Flange.

⚠ CAUTION

Do not remove the Exhaust Flange until the Rotary Valve (40) has been removed from the Valve Chest.

5. Remove Rotary Valve by pulling it out from the assembly through the Motor Housing end of the Rotary Valve Housing.
6. Remove Exhaust Flange.
7. Remove each Cylinder Head (32) by removing Cap Screws (35). Remove Head Gasket (34).
8. To remove Mounting Flange (46), remove Cap Screws, Nuts (50) and Lockwashers (51). Then pull the Mounting Flange straight off.
9. Pull the Cylinder (33) straight out.
10. Position the Piston at the top of its stroke. In this position, with the Cylinder pulled out as in step 9, the Wrist Pin (30) can be removed. For KK5B546 Motors, remove one Pin Retainer (31) from either side of Piston. Push the Wrist Pin out by hand from one side.

⚠ CAUTION

The removal of the Wrist Pin could require the use of heat. Take all precautions necessary to prevent injury from burns. If the Wrist Pin is too tight, carefully heat the Piston to 200° F (93° C) or less and then using a wooden dowel, push out the Wrist Pin.

NOTICE

If Piston, Wrist Pin, Connecting Rod or Cylinder are to be reassembled, number each set. Also, add radial alignment marks for each Piston, Cylinder and Rings to the motor case.

11. Remove the other four Cylinders and Pistons as in steps 9 and 10.
12. Crank Shaft Assembly (16) can now be removed along with the Oil Slinger (17) by pulling straight out from the Motor Housing. Use care while guiding the Connecting Rods (23) through the inside of the Motor Housing.

Crankshaft Disassembly

1. Remove Cotter Pin (21) and the Taper Pin Nut (20).
2. Remove Lock Pin (19) by carefully driving it out of its location. Use care not to damage the threads.
3. Remove Rings (24), Connecting Rod Bushings (25) and Connecting Rods (23). Record number and direction of foot for the five Connecting Rods so they can be installed in the same order.
4. The Oil Slinger does not have to be removed unless damaged.

▲WARNING

If removal of the Oil Slinger is required, heating the Button Head Screws (18) may be required to loosen the Loctite®* connection. Take all precautions necessary to prevent injury from burns.

ASSEMBLY

General instructions

1. Use all new gaskets and seals.
2. Replace worn parts.
3. Lubricate all parts with a mixture of half SAE 20W Oil and half STP.
4. Refer to assembly drawing on page 4 for parts location.

Motor

1. Assemble Bearing (41) to rear of Rotary Valve (40).

NOTICE

Press only on the inner race of the bearing.

Install Seal Ring (42) on the crank shaft end of the Rotary Valve. With the Exhaust Flange (44) down, install Rotary Valve into Rotary Valve Housing (36).

2. Install O-ring Seal (10) into Motor Housing.
3. Install the Rotary Valve Housing Gasket (37) onto Rotary Valve Housing. With the Exhaust Flange down on the bench, install Motor Housing on to Rotary Valve Housing. Check for any evidence of damage to O-ring Seal when the Rotary Valve Housing is fully engaged. Install and tighten Cap Screws (39) to 50 ft-lbs (67.8 Nm) torque.
4. If removed, press Crankshaft Bearing (22) on Crankshaft with seals located as shown in diagram on page 4.

NOTICE

Apply pressure only on the inner race of the bearing.

5. Place Crankshaft on a work bench with the Oil Slinger down and slide the Sleeve (26) (with tang up) on the Crank Pin.
6. Slide Bushing (25), **chamfer up**, over the Sleeve and first Retaining Ring (24).
7. Install the Connecting Rods (23) in the same order as removed, with all feet pointing in the same direction. Use the first Retaining Ring to hold one side of the connecting rod feet.
8. Slide the second Retaining Ring (24), **chamfer down**, over the other side of the connecting rod feet toward the stem of the connecting rod.
9. Tap the Lock Pin (19) in place and install the Nut (20). Tighten the Nut to 60 ft-lbs (81 Nm torque).
10. Install Cotter Pin (21). Repeat steps 7 through 10 to assemble remaining Cylinder Assemblies.
11. Install Timing Pin (43) and Bearing (22) into the valve end of the Crankshaft.
12. Make sure that all Connecting Rods move freely around the crank. Position the Crankshaft Assembly (16) in the Motor Housing (1) so the Bearing is seated and Connecting Rods (23) are centered in the cylinder holes.

NOTICE

Make certain that the Timing Pin and the three lugs on the Rotary Valve line up with the corresponding hole and lugs on the Crankshaft.

* Registered trademark of Loctite Corporation

13. Rotate the Crankshaft so one Connecting Rod is at the top of its stroke. Install a Piston, Compression Ring (28) and Oil Ring (29) on the Connecting Rod using the Wrist Pin (30) and Retaining Rings (31).
14. Install a new Cylinder Gasket (34) before installing the Cylinder.
15. Install the Cylinder (33) over the Piston by compressing the Compression Ring (28) and Oil Ring (29) with a single band ring compressor.
16. Install Cylinder Head (32) over the Cylinder and secure Cylinder Head to Motor Housing (1) with Cap Screws (35). Tighten Cap Screws to 60 ft-lbs (81 Nm) torque.
17. Repeat Steps 13 through 16 to assemble remaining Piston Assemblies.
18. Rotate Motor by hand. There should be no binding.
19. Install Mounting Flange (46) and Gasket (48) on the front of the Motor Housing. Make sure notches on both parts are aligned.
20. Install Cap Screws (49) with Nuts (50) and Lock Washers (51). **Tighten finger tight** to temporarily hold motor.
21. Add oil to the reservoir as described in the **Lubrication** section. Run motor slowly with lubricated air at 100–200 RPM with no load to check for freeness of rotation.
22. Tighten all bolts and run motor at 100–200 rpm for two (2) hours as a break-in period.

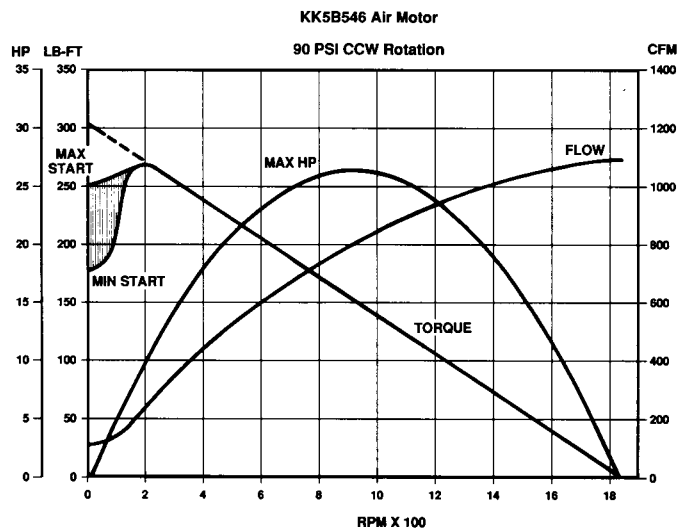

(Dwg. TPD1212)

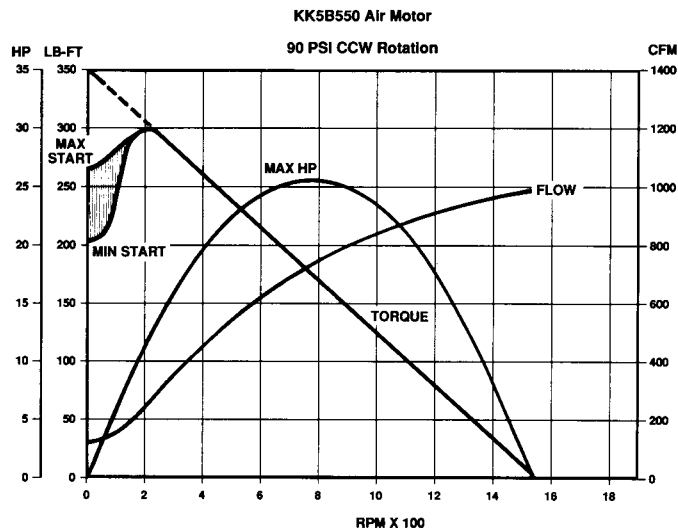

(Dwg. TPD1213)

K5B MANUAL THROTTLE KIT

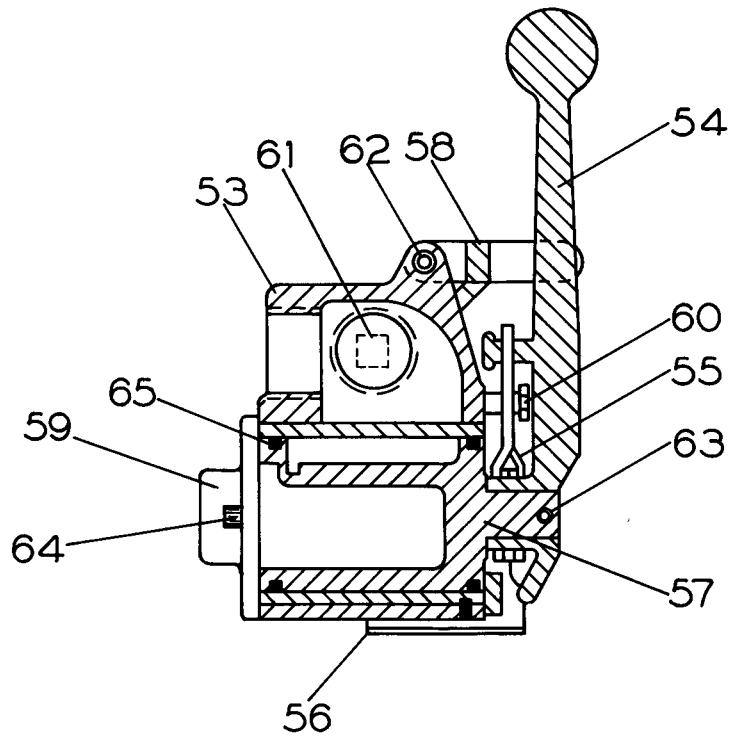

(Dwg. TPD1209)

PART NUMBER FOR ORDERING

	Manual Throttle Kit	K5B-MANUAL
53	Throttle Valve Housing	K5B-1101
54	Throttle Lever	K5B-556
55	Throttle Lever Latch Spring	K5B-412
56	Gasket	K5B-547
57	Throttle Valve Body	KK5B-944
58	Safety Latch	K5B-869
59	Flange	KK5B-276S
60	Retaining Stud	K5B-553
61	Plug (2)	E5UD-947
*	Grease Fitting	23-188
62	Roll Pin	K5B-1115
*	Cap Screw (2)	119A2A198
*	Lock Washer (8)	D02-321
*	Valve Body Retainer	K5B-1110
63	Roll Pin	HLK-20
64	Cap Screw (2)	119A2A198
*	Cap Screw (4)	119A2A202
65	Seal Ring (2)	K5B-606
*	Plug	R0H-377

* Not illustrated.

NOTICE

If control lines are used with the K5B–Manual Throttle, the lines should not exceed 30 feet in length. Control lines longer than 30 feet will have deteriorating response and reduced performance.

⚠ WARNING

Always turn off the air supply and disconnect the air supply hose before installing, removing or adjusting any accessory on this tool, or before performing any maintenance on this tool. Failure to do so could result in injury.

NOTICE

The Throttle Lever Spring (55) should be inspected before operation. During operation, the Throttle Lever Spring should return the Throttle Lever (54) to the neutral or centered position of the Throttle Valve Housing (53). The Throttle Lever Spring should be free from nick, burrs, dirt and contamination. Broken or damaged Throttle Lever Springs must be replaced before operating the Throttle Valve.

⚠ WARNING

Throttle valves with damaged, broken or improperly functioning Throttle Lever Springs (55) should be removed from service. Failure to do so could result in injury.

NOTICE

When replacing the Throttle Lever Spring (55), do not operate the Throttle Lever (54) before the Valve Body Retainer is installed. The Valve Body Retainer limits the throttle movement, preventing the Throttle Lever Spring from becoming over-stressed due to over-travel of the Throttle Lever. After installation, the Throttle Lever Spring should center the Throttle Handle in the neutral position.

DISASSEMBLY

Manual Throttle

NOTICE

Match mark throttle valve parts to ensure proper reassembly.

1. If Manual Throttle is installed on Motor, remove from Motor by removing Cap Screws and Gasket (56).
2. Remove two Cap Screws (not illustrated) that hold the Valve Body Retainer.
3. The Throttle Lever (54) can remain assembled to the Throttle Valve (57) unless parts are damaged.
4. Notice how the Throttle Spring (55) is positioned before removing it. Pull Valve Body out of the Valve Bushing while disconnecting the Throttle Spring.
5. Check parts for score marks or wear. Clearance between the Valve Bushing and Valve should not exceed .002" (.05mm) or excessive air leakage will occur.

ASSEMBLY

1. Install both Seal Rings (65) on the Valve Body (57) and install Valve Body into the Valve Housing (53).
2. Install Valve Body Retainer with two Cap Screws and tighten the Cap Screws to 25 ft–lbs (33 Nm) torque.
3. If Spring Stud (60) was removed during disassembly, reinstall and tighten to 25 ft–lbs (33 Nm) torque.
4. Install Throttle Lever Latch Spring (55) and Throttle Lever (54) on square shaft of Valve Body. The ends of the Spring must straddle the Studs on the Throttle Handle. Install Roll Pin (63).
5. Install Flange (59) to Throttle Valve Housing using Cap Screws (64).
6. Install Throttle Assembly, Gasket and Exhaust Flange (44) on Rotary Valve Housing (36) using Cap Screws. Install Cap Screws (39) that attach Exhaust Flange to Throttle Valve Housing.
7. Tighten Cap Screws (45 and 52) to 25 ft–lbs (33 Nm) torque. Throttle Lever should move freely left and right with no binding and should center from left or right by the spring force only.

K5B NEMA SHAFT KIT

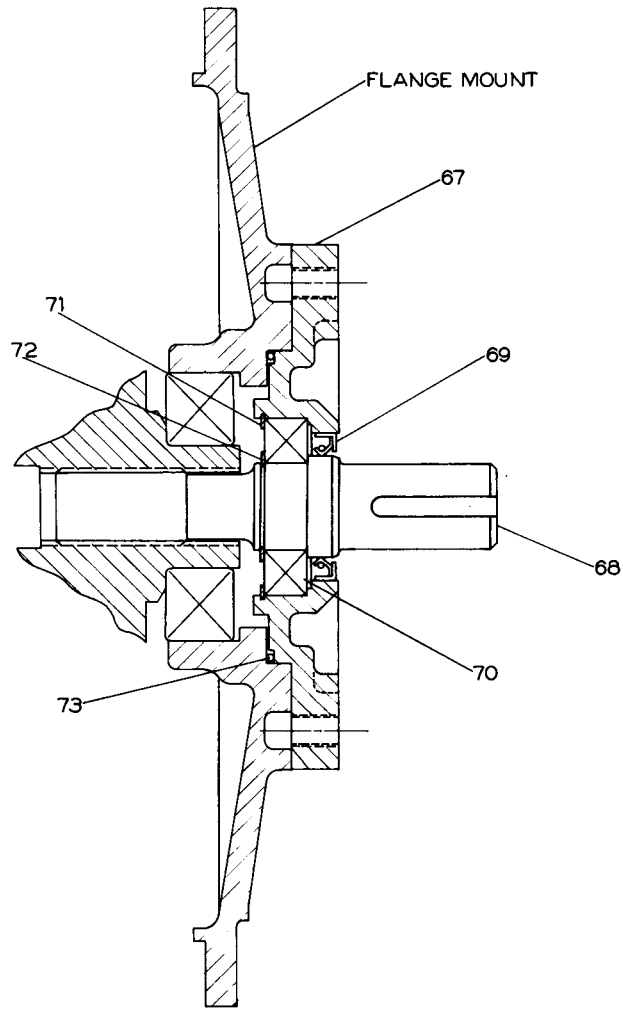

(Dwg. TPB882)

PART NUMBER FOR ORDERING



	NEMA C Shaft Kit	K5B-NEMA-213
67	Adapter	K5B-749NEMA
68	Shaft	K5B-316-213
69	Seal	K5B-270-2
70	Bearing	D10-518
71	Ring	150BM-677
72	Ring	HRA20A-375
73	Seal	SM450B-607-1
*	Cap Screw (4)	BU7A-778
*	Lock Washer (4)	HRA20A-322
*	Key	KK5B-323-1

* Not illustrated.

K5B SHAFT KIT

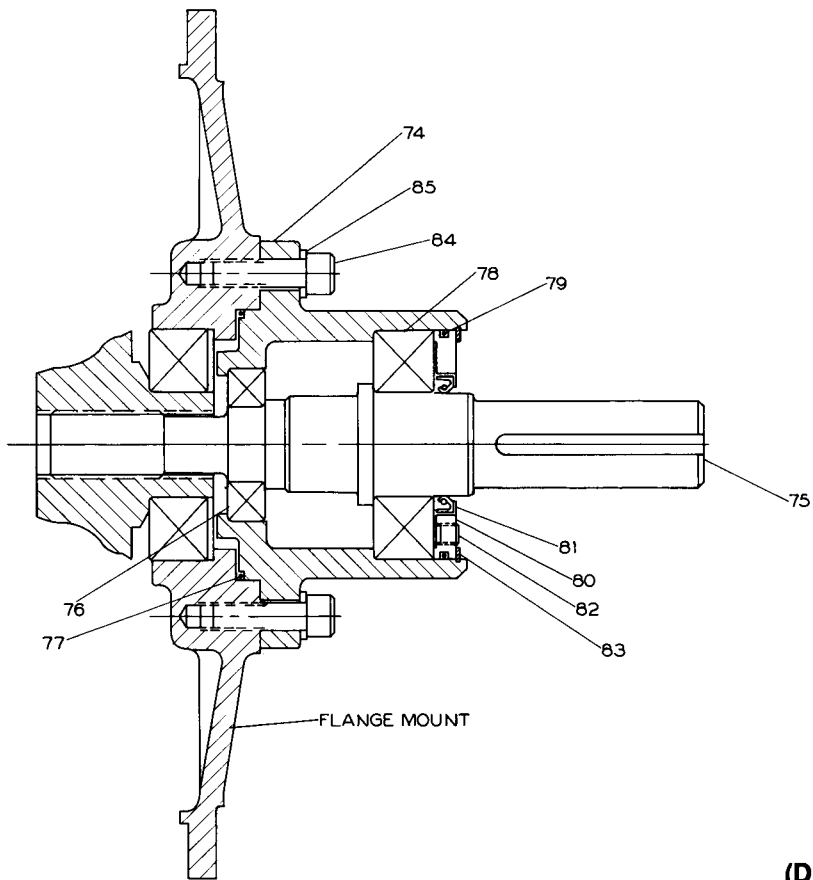

(Dwg. TPB883)

PART NUMBER FOR ORDERING

	Keyed Shaft Kit	K5B-SHAFT-1.625
74	Housing	K5B-749
75	Shaft	K5B-316 1-5/8
76	Bearing	D10-518
77	Seal	SM450B-607-1
78	Bearing	K5B-518
79	Seal	92RMG10-103
80	Holder	K5B-271
81	Seal	K5B-270-1
82	Plug	P250-368
83	Ring	161A13S433
84	Cap Screw	BU7A-778
85	Lock Washer	HRA20A-322
*	Key	KK5B-323-2

* Not illustrated.

K5B-K269 PENDENT CONTROL

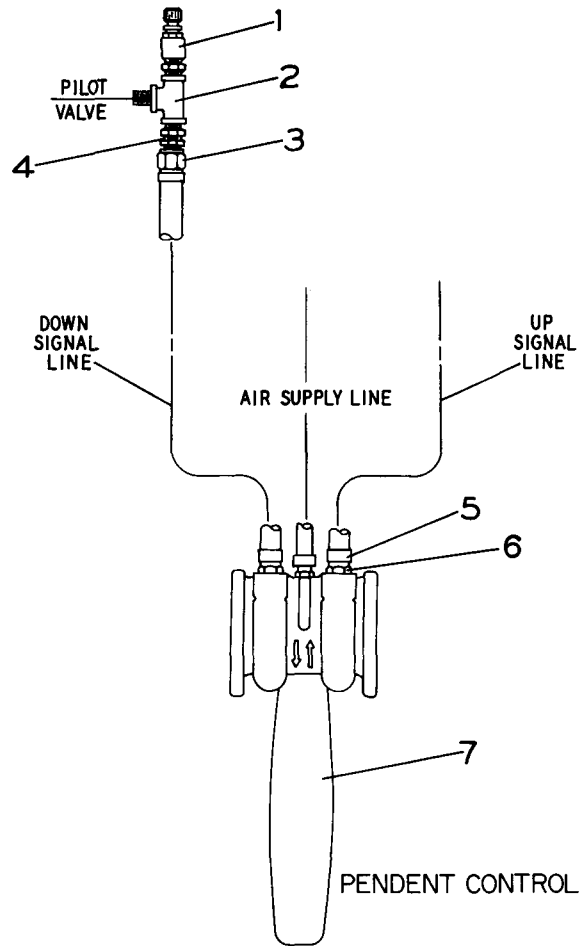

(Dwg. TPC539)

PART NUMBER FOR ORDERING



1	Bleed Valve (2)	HU-264-4
2	Tee (2)	K6U-926
3	Hose Swivel (3)	MLK-162
4	Adapter (2)	4UWD-165
5	Hose Clamp (6)	CA110-476A
6	Straight Fitting (3)	MLK-A170
7	Pendent Handle Assembly	MLK-A269A
*	Nameplate	CA110-598
*	Fastener (2)	CE110-4
*	Strap (9)	HRE20A-283
*	Tag	TA-INS-150

K5B-K269 PENDENT HANDLE

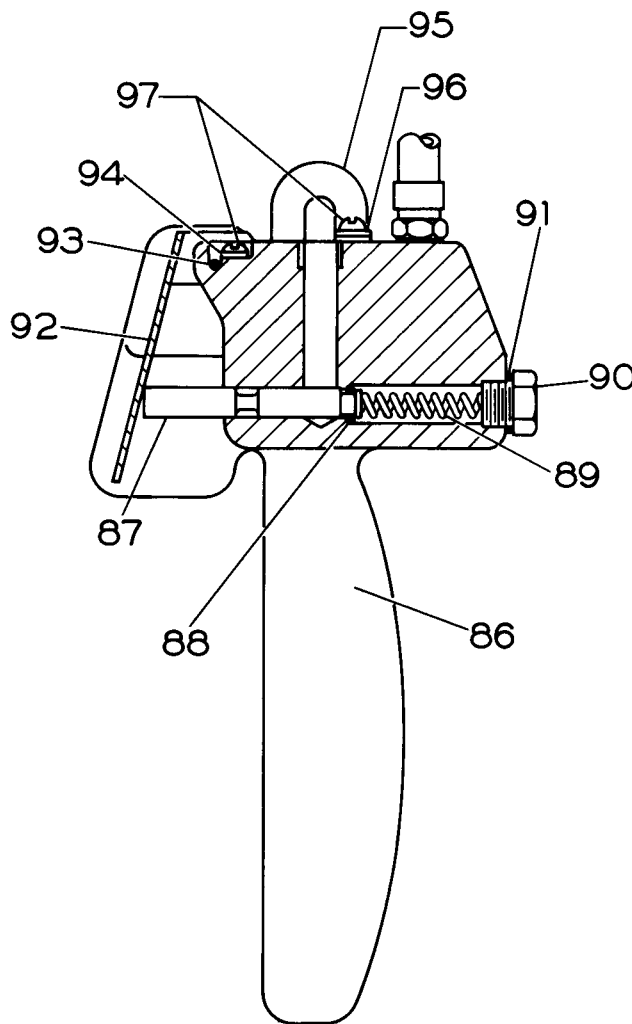

(Dwg. TPD1210)

PART NUMBER FOR ORDERING

	Pendent Handle Assembly	MLK-A269A
86	Pendent Handle	MLK-269
87	Pendent Throttle Valve (2)	MLK-K264A
88	Throttle Valve Face (one for each Valve)	R000BRIC-283
89	Throttle Valve Spring (2)	MLK-51A
90	Throttle Valve Cap (2)	MLK-266A
91	Valve Cap Gasket (2)	MLK-504
92	Throttle Valve Lever (2)	MLK-273
93	Throttle Lever Pin	DLC-120A
94	Pin Lock Washer (2)	D02-138
95	Strain Relief Support	MLK-450
96	Relief Support Lock Washer (2)	H54U-352
97	Handle Screw (4)	HRE20A-68

UWD-A686 CONTROL VALVE WITH UWD-A686 KIT

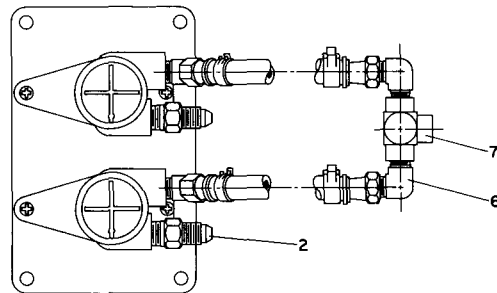
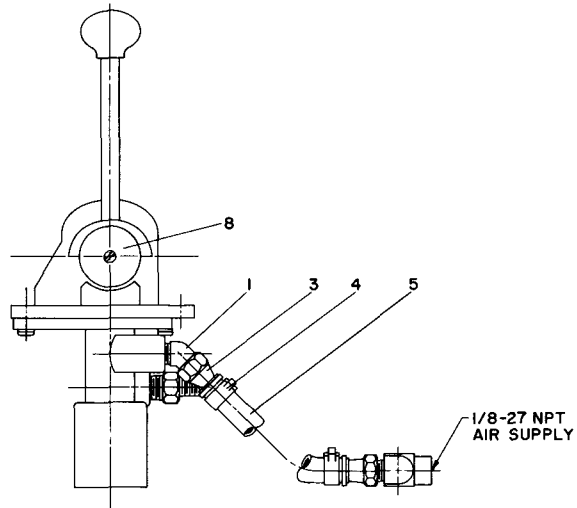

(Dwg. TPB893)

PART NUMBER FOR ORDERING



1	45° Elbow (2) (1/8-27 to 7/16-20)	104A23S01
2	Straight Fitting (2) (1/8-27 to 7/16-20)	108A23S2
3	Swivel (4) (7/16-20 to 1/4 hose)	UWD-162
4	Clamp (4)	CA110-476A
5	Hose (2 feet) (1/4 I.D. x 1/2 O.D.)	BH4A
6	Elbow (2) (90° 1/8-27 to 7/16-20)	MLK-161
7	Tee (1/8-27)	136A23S02
8	Control Valve	UWD-A686

UWD-A686 PANEL MOUNT

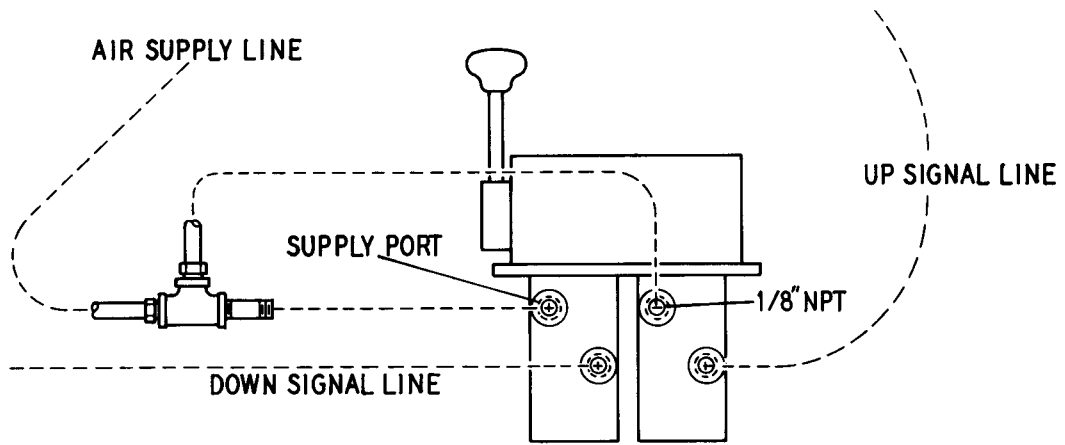

(Dwg. TPD1211)

**HYDRAULIC PUMP HOOK-UP
FOR SERIES KK5B MOTORS**

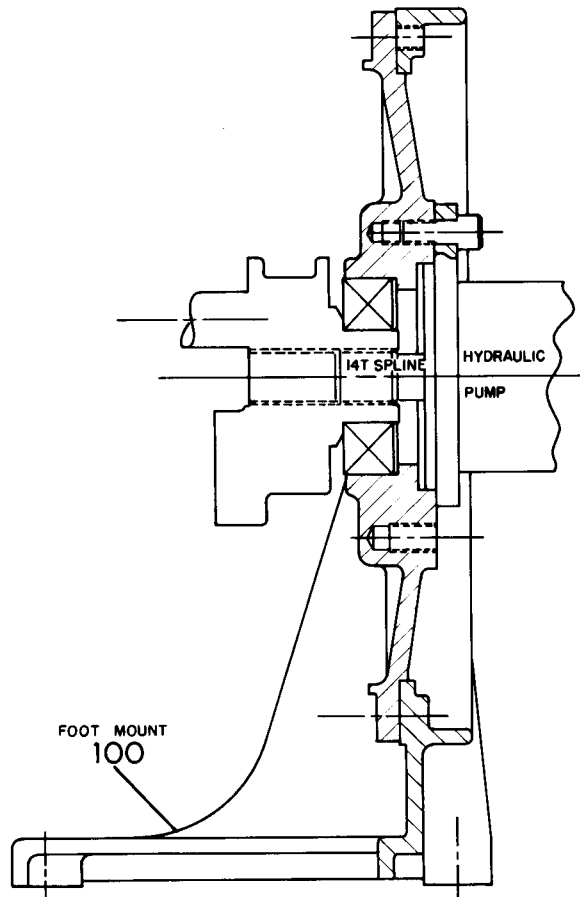

(Dwg. TPC538)

PART NUMBER FOR ORDERING

100	Foot Mount	K5B-FOOT
-----	------------------	----------