

**PISTON-TYPE AIR MOTORS  
REVERSIBLE  
SIZES 25HHWMC1 AND 35KKWMC1  
BASE-MOUNTED  
and  
SIZES 25HHWM56C1 AND 35KKWM56C1  
FLANGE-MOUNTED  
LUBRICATION**

Form P6437  
Edition 1

**P  
A  
R  
T  
S  
  
B  
U  
L  
L  
E  
T  
I  
N**

**WARNING:** Lubricate the Motor before operating. To prevent leakage during shipment, all oil was drained from the Motor Case (1). Sufficient oil for one filling is contained in the can packed with the Motor. Before operating the Motor, check the Magnetic Drain Plug (2) at the bottom of the Motor Case and the Oil Level Plug (3) in the side of the Motor Case to make sure both are secure. Unscrew either Vent Cap (5) and pour entire contents of the can into the Motor Case.

**Check the oil level daily.**

**When the Motor is not subjected to freezing temperatures:** After the Motor has been idle for several hours or overnight, loosen the Magnetic Drain Plug (2) located at the bottom of the Motor Case (1) until the liquid in the Motor Case flows past Plug. Allow to drain until liquid changes from water to oil, then tighten the Plug. Remove the Oil Level Plug located on the side of the Motor Case, and one of the Vent Caps (5) and pour a sufficient quantity of the recommended oil through this opening to bring the oil level up to the open oil level hole. Replace Oil Level Plug and the Vent Cap.

**When the Motor is subjected to freezing temperatures:** Allow the Motor to remain idle long enough for the water content in the Motor Case (1) to separate from the oil, but not long enough for it to freeze. Drain the water and replenish the oil as above. Should this procedure be impractical, drain the entire contents from the Motor Case immediately after operation ceases, and pour the oil back into the Motor Case before resuming operation. If not drained, a sufficient quantity of water will eventually accumulate so that the Oil Splasher (12) attached to the Crank (11) will freeze fast.

**For temperatures 30° to 80° F (-1.1 to 26.6° C),** use Ingersoll-Rand Pneu-Lube® Medium Oil No. 50 or SAE 20 or 20W motor oil.

**For temperatures above 80° F (26.6° C),** use SAE 30 motor oil.

**For temperatures below 30° F (-1.1° C),** use SAE 10 or 20W motor oil. *(Continued on Page 2.)*

### HOW TO ORDER

Order all repair parts for your Ingersoll-Rand Tool by the **NAME** and **NUMBER** shown in the Repair Part List Section. **Never** use the illustration numbers which appear in the first column.

For prompt service and genuine Ingersoll-Rand parts, place orders with the nearest Ingersoll-Rand Office or Authorized Distributor.

**Notice:** The use of other than genuine Ingersoll-Rand replacement parts may result in decreased tool performance and increased maintenance, and may, at the Company's option, invalidate all warranties.

**FOR ADDITIONAL REPAIR SERVICE INFORMATION, REQUEST SERVICE BULLETIN S6437.**

Refer All Communications to the Nearest  
Ingersoll-Rand Office or Distributor.

© Ingersoll-Rand Company 1978

Printed in U.S.A.



**Ingersoll-Rand®**

Every three months, or as experience indicates, remove the Grease Plug (44) from the Base (42) and fill the chamber with Ingersoll-Rand Heavy Gear Grease No. 70.

**Ingersoll-Rand Air Line Lubricators and Strainers are recommended for use with all Stationary Motors.**

The No. SM450-A267AT Strainer and No. NL-32M Lubricator can be used in combination if a separate Strainer and Lubricator arrangement is desired. In selecting any other lubricator, strainer or filter arrangement make sure that its air passage capacity is sufficiently great to avoid restriction of compressed air to the Motor. For optimum performance, Sizes 25HHWMC1 and 25HHWM56C1 require 760 to 800 scfm at 90 psig (6.2 bar/620 kPa) while Sizes 35KKWMC1 and 35KKWM56C1 require 1000 to 1100 scfm.

## INSTALLATION

A four-way valve is required because the reverse inlet is an auxiliary exhaust port when the Motor is operated in forward direction, and the forward inlet is the auxiliary exhaust port for reverse operation.

When selecting a valve, be sure to choose one that has an air passage capacity great enough to meet the demands of the Motors as defined in the foregoing paragraphs covering Strainers and Lubricators.

**CAUTION:** These Motors should be sufficiently loaded to prevent sustained speeds in excess of 1700 rpm for Size 25HHWMC1 or 25HHWM56C1; 1300 rpm for Size 35KKWMC1 or 35KKWM56C1. Higher speeds, except intermittently, will result in serious damage.

The Motor Case of a Stationary Motor can be rotated to any one of several different positions on the Base. When installation requires that the foot pad of the Base be attached to a wall or column so that it is not in a horizontal plane, the Motor Case must be removed from the Base and rotated. Position the Motor Case so that the Magnetic Drain Plug (2) is at, or not more than 20° from, the bottom vertical center.

**Note:** The bolt spacing of the Motor Case and Base is such that if the Motor is to be mounted in an inverted position with the foot pad at the top, or if the Motor is to be mounted on a wall or column so that the foot pad is vertical, a special Base must be used. Otherwise the Motor Case will be excessively tilted.

**Caution:** Stationary Motors should be mounted so that the axis of the Motor Shaft is horizontal. Operation of the Motor with the axis of the Shaft more than 10° from horizontal will result in lubrication difficulties.

### Mounting Instructions for Series 56 Flange-Mounted Motors

These Motors can be mounted by either of two methods.

**For Method No. 1,** provide a mounting with a counterbore which is a close fit on the small diameter pilot on the Motor Mounting Cover (54) and with four mounting bolt holes that align with the four tapped holes in the Cover. Use mounting bolts that will enter no more than 1" (25.4 mm) into the tapped holes in the Cover.

**For Method No. 2,** provide a mounting with a counterbore which is a close fit on the large diameter pilot on the Motor Mounting Cover (54) and with a series of tapped holes that align with the bolt holes through the flanges on the Motor Case (1) and Motor Case Cover. Use the Motor Case Bolts (57) or replace these with longer ones if necessary, for attaching the motor assembly to the mounting.

Always provide a bearing for the outer end of the Motor Shaft. Locate it as far from the Motor as possible and be very careful to get good alignment.

Always provide an outboard bearing for pinions or shaft extensions. They cannot be overhung from the Motor Shaft.

Do not make shaft extensions a tight fit in the broached hole in the crank. An outboard bearing cannot be perfectly aligned with the crank bearings and the splined fit must act to a limited extent as a flexible coupling. Dimensions recommended for Motor Shaft splines will be furnished on receipt of mounting details and outboard bearing location. The Motor Shaft must be supported in such a manner that no **end thrust** will be transferred to the crank.

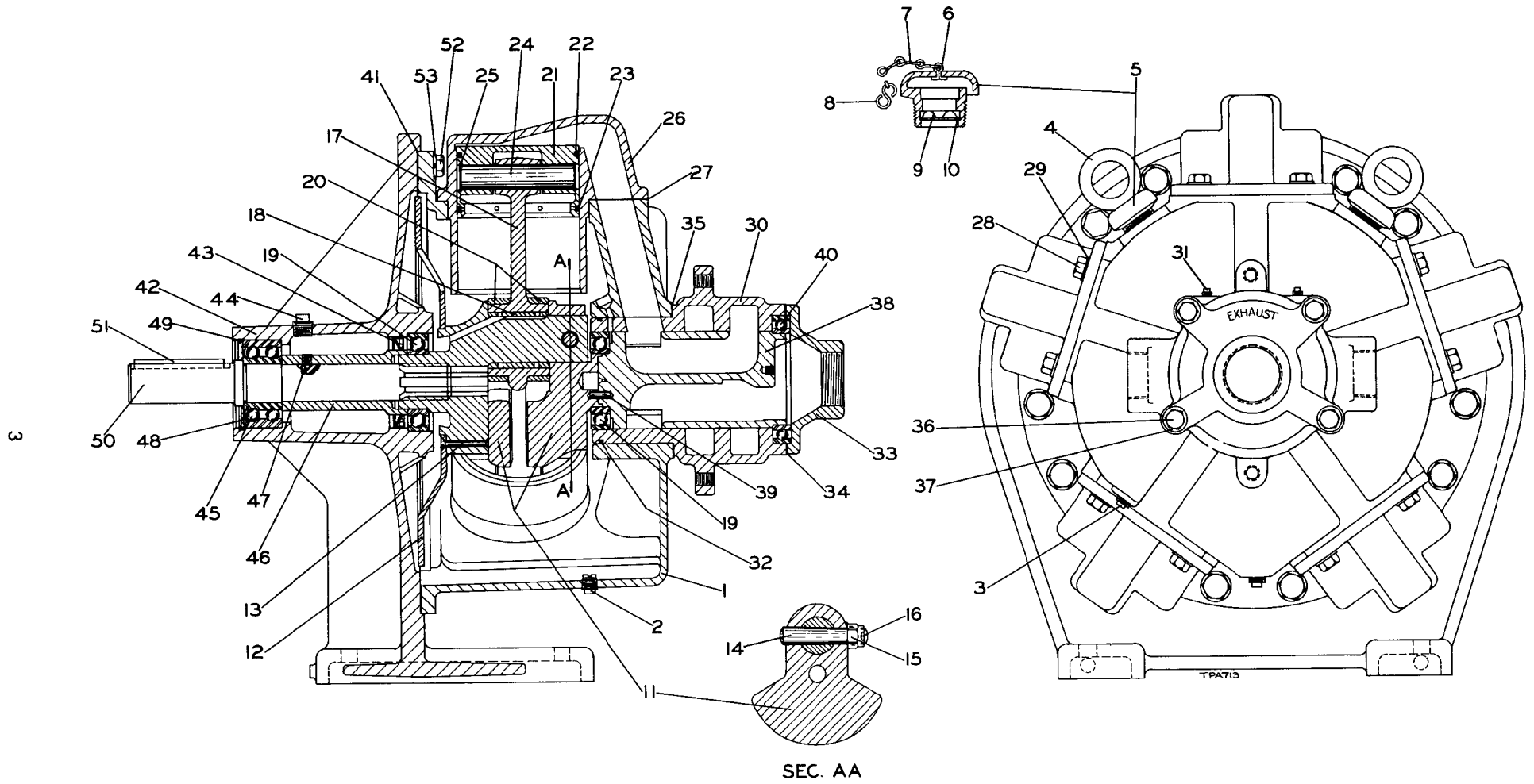

Size 35KKWMC1 Base-Mounted Motor

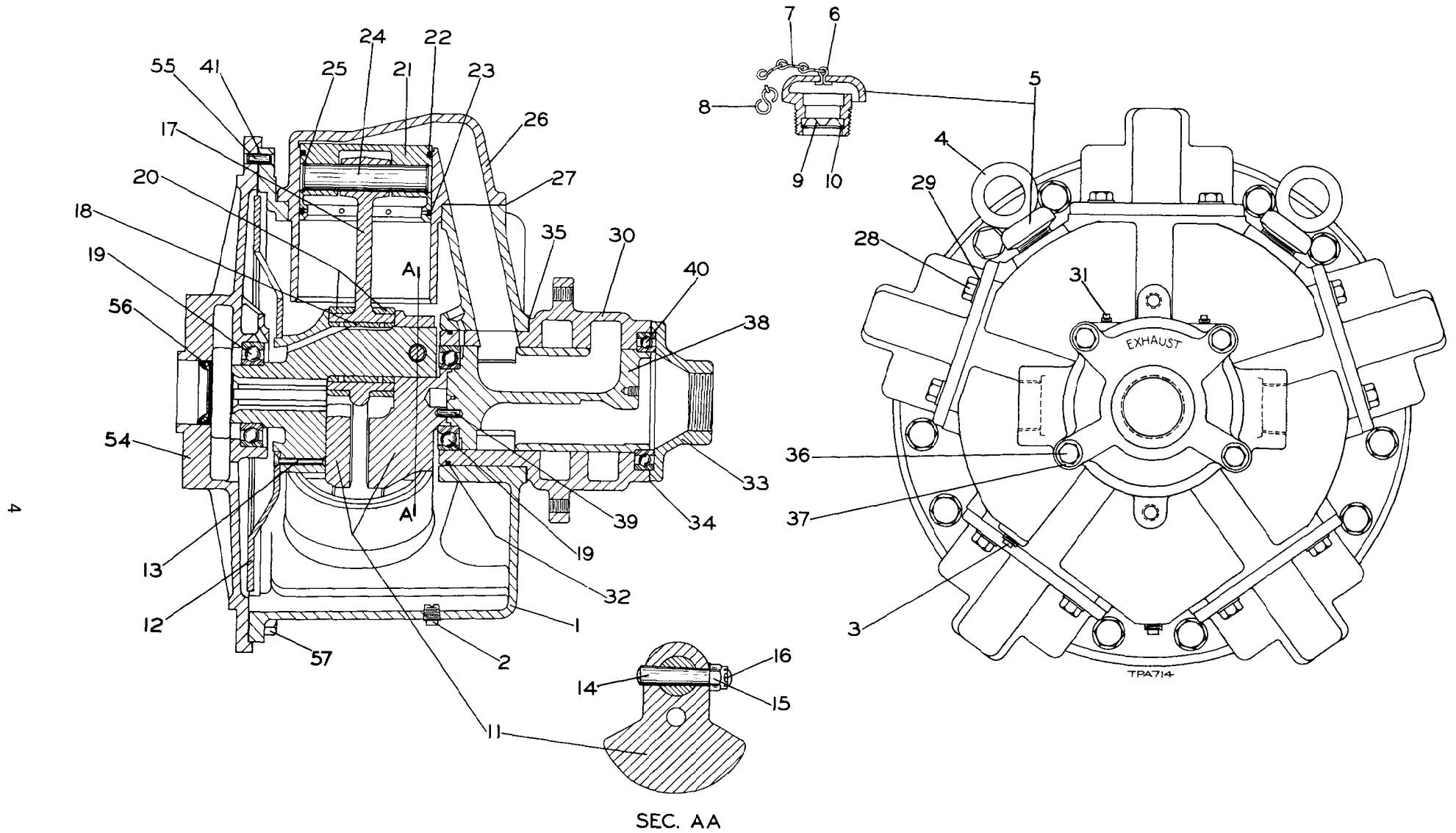

Flange-Mounted Motors Size 25HHWMC561 or 35KKWMC561

PARTS IN THE FOLLOWING LIST ARE USED ONLY IN BASE-MOUNTED MOTORS

PART NUMBER FOR ORDERING

		25HHWMC1 25HHWM56C1	35KKWMC1 35KKWM56C1
1	Motor Case.....	H5W-501	K5W-501
2	Magnetic Drain Plug .....	K5W-29	K5W-29
3	Oil Level Plug .....	D02-402	D02-402
4	Motor Case Eye Bolt (2).....	KU-888	KU-888
*	Motor Nameplate .....	K5W-99	K5W-99
*	Nameplate Screw (6).....	R4K-302	R4K-302
5	Vent Cap (2) .....	D02-302A	D02-302A
6	Vent Cap Cotter .....	D02-893	D02-893
7	Vent Cap Chain .....	D02-891	D02-891
8	S-Hook .....	D02-421	D02-421
9	Vent Cap Screen .....	D02-889	D02-889
10	Vent Cap Screen Retainer .....	6CND-231-1/2	6CND-231-1/2
	Crank Assembly .....	H5W-A516	K5W-A516
11	Bare Crank (consists of matched parts, none of which is sold separately).....	H5W-516	K5W-516
12	Oil Splasher .....	HU-540	KU-540
13	Splasher Rivet, Long (2).....	HU-541	K5W-541
*	Splasher Rivet, Short (2).....	231-712	KU-542
14	Crank Lock Pin.....	HU-520	K5W-520
15	Lock Pin Nut .....	D02-394	D02-317
16	Lock Pin Cotter .....	D02-524	D02-330
*	Crank Pin Sleeve .....	HU-519	----
17	Connecting Rod (5) .....	HH5D-509	K5M-509
18	Connecting Rod Bushing .....	HU-511	K5W-511
19	Crank Bearing (2).....	HU-518	KU-518
20	Connecting Rod Ring (2).....	HU-510	KU-510
21	Piston (5) .....	H5W-513	K5W-513
22	Piston Ring (one for each Piston).....	HU-337	KU-337
23	Oil Regulating Ring (one for each Piston).....	HU-338	KU-338
24	Wrist Pin (5).....	H5W-514	K5W-514
25	Wrist Pin Retainer (10).....	902A45-632	ILA902A9-589
26	Cylinder (5) .....	----	K5W-505
*	Cylinder Head (5) .....	H5W-H505	----
*	Cylinder Liner (5) .....	HH5D-L505A	----
27	Cylinder Gasket (5) .....	H5W-507	K5W-507
28	Cylinder Cap Screw (20).....	D10-354	215-13
29	Cylinder Cap Screw Washer (20) .....	HU-504	KU-504
30	Valve Chest.....	HHWMC-545	KKWMC-545
31	1/4" Pipe Plug (2) .....	D02-402	D02-402
32	O-ring .....	11BMP-338	SM450B-607-1
33	Valve Chest Cover .....	H5W-546	K5W-546
34	Valve Chest Cover Gasket .....	H5W-928	K5W-928
35	Valve Chest Gasket .....	H5W-547	K5W-547
36	Valve Chest Screw (4) .....	12BMP-634	K5W-548
37	Lock Washer (4) .....	D02-321	D10-322
38	Rotary Valve .....	25HHWMC1-526	35KKWMC1-526
39	Valve Drive Pin.....	510-669A	510-669A
40	Valve Bearing .....	H5W-97	21-703
41	Motor Gasket .....	HH5D-592	K5W-592

\* Not illustrated.

**PARTS IN THE FOLLOWING LIST ARE USED ONLY IN BASE-MOUNTED MOTORS  
SIZES 25HHWMC1 AND 35KKWMC1**

		PART NUMBER FOR ORDERING	
		↓	↓
		25HHWMC1	35KKWMC1
42	Base .....	H5M-292	K5W-292
43	Oil Seal .....	HM-270	KM-270
44	Grease Plug .....	D02-351	D02-351
45	Motor Shaft Bearing .....	E3G-763	D10-825
46	Bearing Spacer .....	HM-41	KM-41
47	Spacer Set Screw.....	C04-31	C04-31
48	Dust Washer .....	HM-298	KM-298A
49	Retaining Ring.....	HM-295	KM-295
50	Motor Shaft .....	HM-294	KM-294A
51	Shaft Key .....	E9G-758	D04-323
52	Motor Mounting Bolt (20).....	215-148	215-36
53	Lock Washer (10).....	D10-322	A-67

**PARTS IN THE FOLLOWING LIST ARE USED ONLY IN FLANGE-MOUNTED MOTORS  
SIZES 25HHWM56C1 AND 35KKWM56C1**

		PART NUMBER FOR ORDERING	
		↓	↓
		25HHWM56C1	35KKWM56C1
54	Motor Mounting Cover .....	H5M-276	K5M-276
55	Dowel .....	D02-347	D02-347
56	Oil Seal .....	HM-271	KM-271
57	Motor Mounting Bolt (10) .....	215-37	KX36
*	Mounting Bolt Nut (10).....	215-182	HU-776
*	Lock Washer (10).....	D10-322	A-67
*	Motor Shaft (Blank, or finished to customer's specifications).....	HM-277	KM-277

\* Not illustrated.

## AIR STRAINER

ILLUS. NUMBER (Do not use for ordering)	PART NAME FOR ORDERING  (Parts indented after an item are included with that item)	PART NUMBER FOR ORDERING
400	Air Strainer Assembly .....	SM450-A267AT
401	Air Strainer Screen .....	SM450-61AT
403	Air Strainer Plug .....	TA-464
404	Air Strainer Cap.....	SM450-268AT

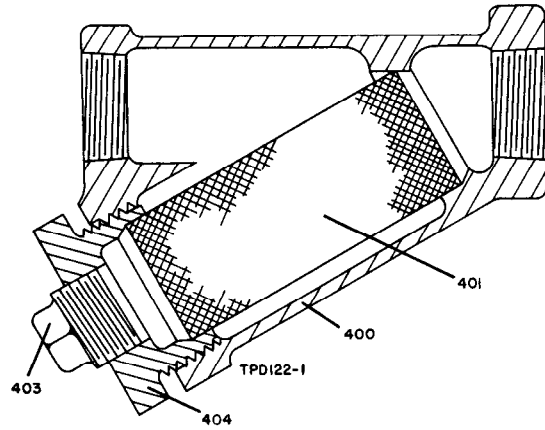

## MAINTENANCE TOOLS

TOOL NUMBER FOR ORDERING	TOOL NAME FOR ORDERING	OPERATION
HU-932	Valve Chest Jack Bolt (2) .....	Removing the Valve Chest (30) from the Motor Case (1). Compressing the Piston Rings (22 and 23) when installing a Cylinder Liner (26) on Size 25HHWMC1 or 25HHWM56C1 Motor.
HU-933	Piston Ring Compressor .....	
KU-933	Piston Ring Compressor .....	Compressing the Piston Rings (22 and 23) when installing a Cylinder (26) on Size 35KKWMC1 or 35KKWM56C1 Motor.

● **Atlanta, Ga.**  
111 Ingersoll-Rand Drive  
Chamblee, Georgia 30341

★ **Baton Rouge, La.** 70816  
4152 Rhoda Drive

★ **Birmingham, Ala.** 35233  
1516 Second Ave., South

★ **Boston, Mass.**  
2 Kuniholm Dr.  
Holliston, Mass. 01746

★ **Buffalo, N. Y.** 14225  
195 Sugg Rd.

● **Charlotte, N. C.** 28208  
4840 Wilmont Rd.

★ **Chattanooga, Tenn.** 37407  
1936 Central Ave.

● **Chicago, Ill.**  
888 Industrial Drive  
Elmhurst, Illinois 60126

★ **Cincinnati, Ohio**  
666 Redna Terrace  
Woodlawn, Ohio 45215

★ **Cleveland, Ohio** 44125  
9257 Midwest Ave.

★ **Corpus Christi, Texas** 78408  
4540 Baldwin Blvd.

● **Dallas, Texas** 75247  
8901 Directors Row

★ **Denver, Colo.** 80207  
5805 E. 39th Ave.

● **Detroit, Mich.**  
22122 Telegraph Road  
Southfield, Mich. 48075

## Ingersoll-Rand®

Tool & Hoist Division  
28 Kennedy Blvd.  
East Brunswick, N. J. 08816

★ **Freeport, Texas** 77541  
211 Park Place

● **Hartford, Conn.**  
60 Progress Drive  
Manchester, Conn. 06040

● **Houston, Texas** 77001  
6800 Sands Point, P.O. 1455

★ **Indianapolis, Ind.** 46268  
5315 West 86th St.

● **Los Angeles, Calif.** 90022  
5533 East Olympic Blvd.

● **Milwaukee, Wis.**  
N84 W13540 Leon Rd.  
Menomonee Falls, Wis.  
53051

★ **Minneapolis, Minn.** 55404  
Corner Franklin & Cedar

★ **Moline, Ill.** 61265  
3901 25 St.

★ **Newark, N. J.**  
28 Kennedy Blvd.  
East Brunswick, N. J. 08816

● **New Orleans, La.** 70005  
939 Lake Ave. Metairie

★ **Peoria, Ill.** 61614  
1809 West Chanute Rd.

● **Philadelphia, Pa.**  
651 Park Ave.  
King of Prussia, Pa. 19406

● **Pittsburgh, Pa.** 15220  
6 Parkway Ctr.

★ **Port Arthur, Texas** 77640  
5336 Twin City Highway

★ **Portland, Oregon** 97214  
240 S. E. Clay St.

★ **Richmond, Va.** 23230  
3431 West Leigh St.

★ **San Francisco, Calif.**  
14299 Wicks Blvd.  
San Leandro, Calif. 94577

● **Seattle, Wash.** 98188  
345 Andover Park East

★ **Shreveport, La.** 71106  
450 W. 61st St.

● **St. Louis, Mo.** 63132  
1515 Page Industrial Blvd.

★ **Tampa, Fla.** 33609  
3316 South Westshore Blvd.

★ **Washington, D. C.** 20006  
1666 K. St., N. W.

● **Branch and All Star® Servicer.**  
★ **All Star Servicer only.**

### CANADA

● **Calgary, Alberta,** T2R 0E1  
611 11th Ave., S. W.

● **Montreal, Quebec**  
620 Cathcart St., H3B 1M2  
P.O. Box 1148, H3B 3K9

● **Sherbrooke, Quebec,** J1H 3X4  
375 Courcellette St.

● **Sudbury, Ontario,** P3A 3T3  
P.O. Box 2220

Canadian Ingersoll-Rand Co., Limited  
Montreal, Quebec  
620 Cathcart St., H3B 1M2  
P.O. Box 610, Station B H3B 3K3

● **Toronto**  
Don Mills, Ontario M3B 2V1  
255 Lesmill Road

● **Vancouver**  
British Columbia, V6A 2W7  
1695 Main St.

● **Winnipeg, Manitoba,** R3H 0M6  
1234 Border St.

● **All Star Servicer.**

5-67

### AUTONOMOUS COMPANIES

● **Argentina, Buenos Aires**  
Ingersoll-Rand Argentina  
S.A.I.y C.  
Casilla Correo 2412, Correo Central

● **Australia, South Melbourne**  
Ingersoll-Rand (Australia) Ltd.  
P.O. Box 219  
42 Moray Street, 3205 Victoria

● **Austria A 1120, Vienna**  
Ingersoll-Rand Ges M.B.H.  
Schoenbrunnerstrasse 213-215/2/5

● **Belgium, Diegem (Brussels)**  
Ingersoll-Rand Benelux S.A.  
Kouterveldstraat 10-12, 1920 Diegem

● **Brazil, Sao Bernardo**  
Ingersoll-Rand S.A. Ind. e Com.  
Caixa Postal 911

● **Chile, Santiago**  
Ingersoll-Rand Chile  
Morande 341  
Casilla 126-D

● **Colombia, Bogota**  
Macquinarias Ingersoll-Rand  
de Colombia, S.A.  
Apartado Aero 7451

● **Denmark, Albertslund DK2620**  
Ingersoll-Rand AB  
Herstedvang 11

● **Egypt, Cairo**  
Ingersoll-Rand North East Africa  
P.O. Box 820  
23A Ismail Mohamed St.  
Zamalek

● **England, London, SW1X, 7LU**  
Ingersoll-Rand Co., Ltd.  
Bowater House, Knightsbridge

● **France, 78 190 Trappes Yvelines**  
Compagnie Ingersoll-Rand  
Avenue Albert Einstein  
Zone Industrielle

● **Germany, 403 Ratingen**  
Ingersoll-Rand GmbH  
Robt. Zapp Str. 7  
Postfach 1380

● **Greece, Athens 610**  
Ingersoll-Rand Central Middle East  
17th Floor Athens Tower  
Mesogion-2-4

● **Hong Kong**  
Ingersoll-Rand Far East  
19th Floor, Lap Heng House  
50, Gloucester Road

● **India, Bombay 400018**  
Ingersoll-Rand (India) Private Ltd.  
44 Maulana Abdul Gaffar Rd.  
P.O. Box 16564, Worli

● **Iran, Tehran**  
Ingersoll-Rand Iran  
P.O. Box 12-1538

● **Ireland, Dublin**  
Ingersoll-Rand Company (Ireland) Ltd.  
John F. Kennedy Drive  
Bluebell

● **Italy, 20100 Milano**  
Ingersoll-Rand Italiana, S.p.A.  
Strada Provinciale Cassanese  
Caselle Postale 1232  
Vignate, Italy

● **Japan, 106 Tokyo**  
Ingersoll-Rand (Japan) Ltd.  
Kowa Bldg. No. 17  
2-7 Nishi-Azabu 1-Chome  
Minato-Ku

● **Kenya, Nairobi**  
Ingersoll-Rand Mid Africa  
P.O. Box 14240

● **Malaysia, Petaling Jaya**  
Ingersoll-Rand Malaysia, Sdn. Bhd.  
P.O. Box No. 125

● **Mexico, 10 D.F. Mexico**  
Ingersoll-Rand S.A. de C.V.  
Apartado 41-666

● **Netherlands, Zoeterwoude**  
Ingersoll-Rand Benelux N.V.  
P.O. Box 33, Zoeterwoude

● **Norway, Oslo 1**  
Ingersoll-Rand AB  
P.O. Box 143-Sentrum

● **Peru, Lima**  
Ingersoll-Rand Co. of Peru, S.A.  
Casilla 2261

● **Philippines, Makati, Rizal 3117**  
Ingersoll-Rand Philippines, Inc.  
P.O. Box 445 MCC

● **Portugal, Lisbon 5**  
Ingersoll-Rand Lda.  
Apartado 2933

● **Puerto Rico, San Juan 00936**  
Ingersoll-Rand de Puerto Rico Inc.  
G.P.O. Box 1222

● **Singapore 22**  
Ingersoll-Rand Southeast Asia (Pte.) Ltd.  
G.P.O. Box 2062, Singapore 1

● **South Africa, Alberton**  
Ingersoll-Rand Co. S.A. (Proprietary) Ltd.  
P.O. Box 3720  
Alrode, 1451

● **Spain, Madrid**  
Cia. Ingersoll-Rand, S.A.  
Apartado 518

● **Sweden, Bromma**  
Ingersoll-Rand A.B.  
Fack  
S-16125 Bromma 1

● **Venezuela, Caracas**  
Ingersoll-Rand de Venezuela S.A.  
Apartado 70588, Los Ruices

5-67

## AUTHORIZED I-R SALES AND SERVICE

Distributors in principal cities throughout the world. Contact the nearest Ingersoll-Rand office for the name and address of the distributor in your country or write to Ingersoll-Rand International, Woodcliff Lake, New Jersey.