

**OPERATION AND MAINTENANCE MANUAL**  
for  
**MODELS 1801N, 1801P, 1801Q, 1801U**  
**AND 1801W NONREVERSIBLE**  
and  
**MODELS 1841N, 1841P, 1841Q, 1841U**  
**AND 1841W REVERSIBLE**  
**MULTI-VANE <sup>®</sup> AIR MOTORS**

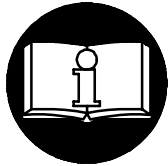

**! WARNING**

**IMPORTANT SAFETY INFORMATION ENCLOSED.  
READ THIS MANUAL BEFORE OPERATING TOOL.**

**FAILURE TO OBSERVE THE FOLLOWING WARNINGS COULD RESULT IN INJURY.**

- Always operate, inspect and maintain this motor in accordance with American National Standards Institute Safety Code for Portable Air Tools (ANSI B186.1).
- For safety, top performance and maximum durability of parts, operate this motor at 90 psig (6.2 bar/620 kPa) air pressure at the inlet with 1/2" (13 mm) air supply hose.
- Always turn off the air supply and disconnect the air supply hose before installing, removing or adjusting any accessory on this motor.
- Keep hands, loose clothing and long hair away from rotating end of motor.
- Anticipate and be alert for sudden changes in motion during start up and operation of any motor.
- Motor shaft may continue to rotate briefly after the throttle is released.
- Do not lubricate motor with flammable or volatile liquids such as kerosene, diesel or jet fuel.
- Do not remove any labels. Replace and damaged label.
- Use accessories recommended by Ingersoll-Rand.
- This motor is not designed for working in explosive atmospheres.
- This motor is not insulated against electric shock.

**NOTICE**

The use of other than genuine Ingersoll-Rand replacement parts may result in safety hazards, decreased tool performance and increased maintenance, and may invalidate all warranties.

Ingersoll-Rand is not responsible for customer modification of tools for applications on which Ingersoll-Rand was not consulted.

Repairs should be made only by authorized, trained personnel. Consult your nearest Ingersoll-Rand Authorized Servicenter.

It is the responsibility of the employer to place the information in this manual into the hands of the operator.

## WARNING LABEL IDENTIFICATION

### ⚠ WARNING

FAILURE TO OBSERVE THE FOLLOWING WARNINGS COULD RESULT IN INJURY.

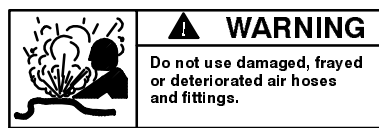
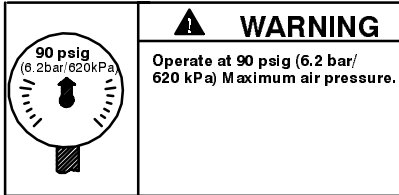
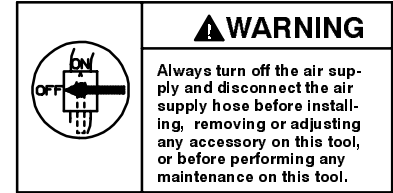
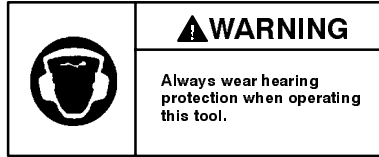
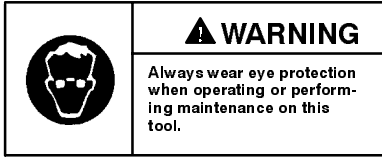

## PLACING TOOL IN SERVICE

### LUBRICATION



#### Ingersoll-Rand No. 50 Ingersoll-Rand No. 100

We recommend using a Filter-Lubricator -Regulator Unit with these Motors. Use No. C11-03-G00 (3/8" pipe tap inlet). Install the Unit as close to the Motor as practical. Keep the Lubricator filled with Ingersoll-Rand No. 50 Oil.

After each forty hours of operation, or as experience indicates, remove the Grease Plug (29) and inject 1.5 cc of the recommended grease into the opening. Do not grease excessively. Too much grease in the Gear Case (28) will cause heating. Grease leakage from the spindle end is also an indication that an excessive amount of grease has accumulated within the Gear Case.

### DIRECTION OF SPINDLE ROTATION

Series 1801 Nonreversible Motors can be assembled so that the Spindle rotates either clockwise or counterclockwise.

To reverse the direction of the spindle rotation:

1. Remove the motor assembly from the Motor Housing (14).

2. Remove one End Plate and Bearing assembly from the motor.
3. Lift the Cylinder (15) from the Rotor (12), turn it end for end, and slide it back over the Rotor.
4. Install the End Plate and Bearing assembly on the rotor hub and install the assembled motor in the housing.
5. Remove the two Backhead Cap Screws (4) and rotate the Backhead (2) and Backhead Gasket (6) 90° so that the cavity in the face of the Backhead is in alignment with the alternate set of holes in the back face of the Motor Housing. When the Backhead is correctly applied, the cavity will be over the letter "F" for counterclockwise spindle rotation (when facing the end of the Spindle), and over the letter "R" for clockwise rotation.

The rotational direction of an assembled Nonreversible Series 1801 Motor can be determined by removing the Air Strainer (1) and looking through the tapped opening to see whether the letter "F" or letter "R" is visible.

Apply the Backhead on Series 1841 Reversible Motors so that each inlet port aligns with a group of three holes through the housing rear wall.

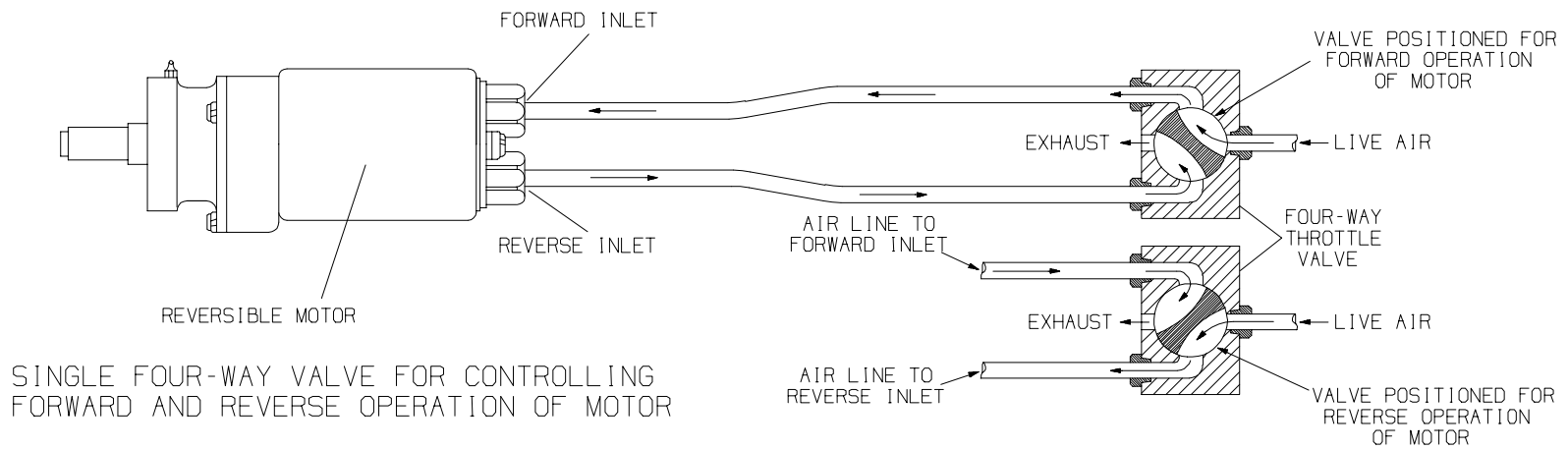

SINGLE FOUR-WAY VALVE FOR CONTROLLING FORWARD AND REVERSE OPERATION OF MOTOR

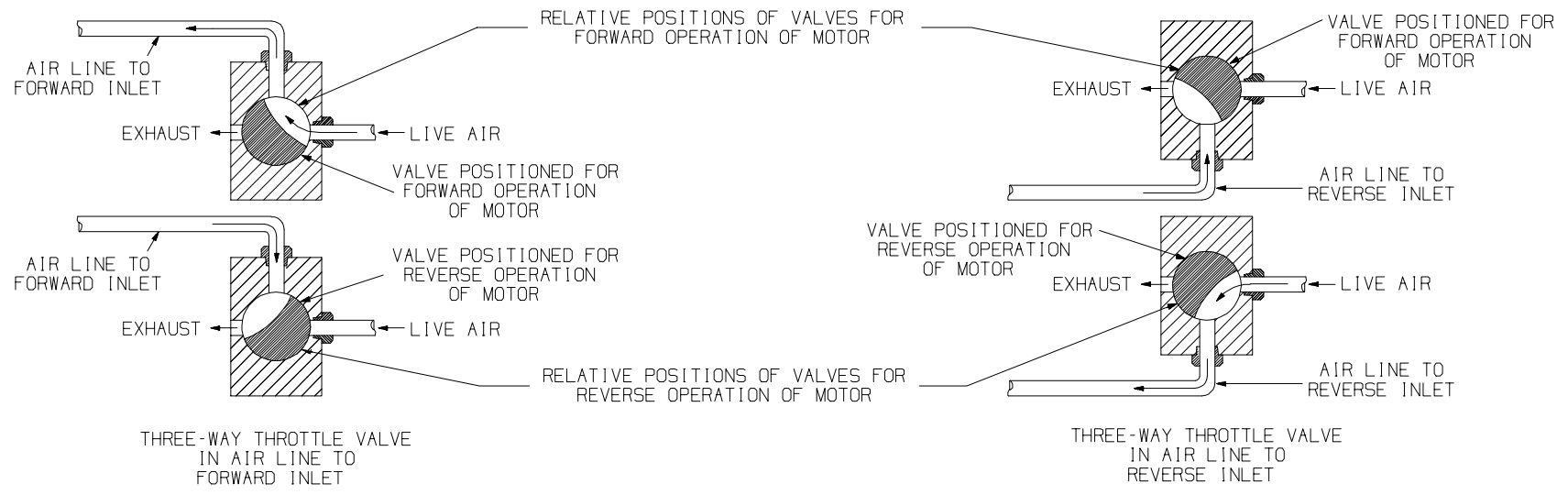

TWO THREE-WAY VALVES FOR CONTROLLING FORWARD AND REVERSE OPERATION OF MOTOR

BACKHEAD USED ON SERIES 1801  
NON-REVERSIBLE MOTORS

BACKHEAD USED ON SERIES  
1841 REVERSIBLE MOTORS

21 USED ONLY IN 'p' RATIO

OPTIONAL SPINDLE WITH  
1/2" SQUARE DRIVER

SERIES 1801 OR 1841 AIR MOTOR

(Dwg. TPB183-1)

4

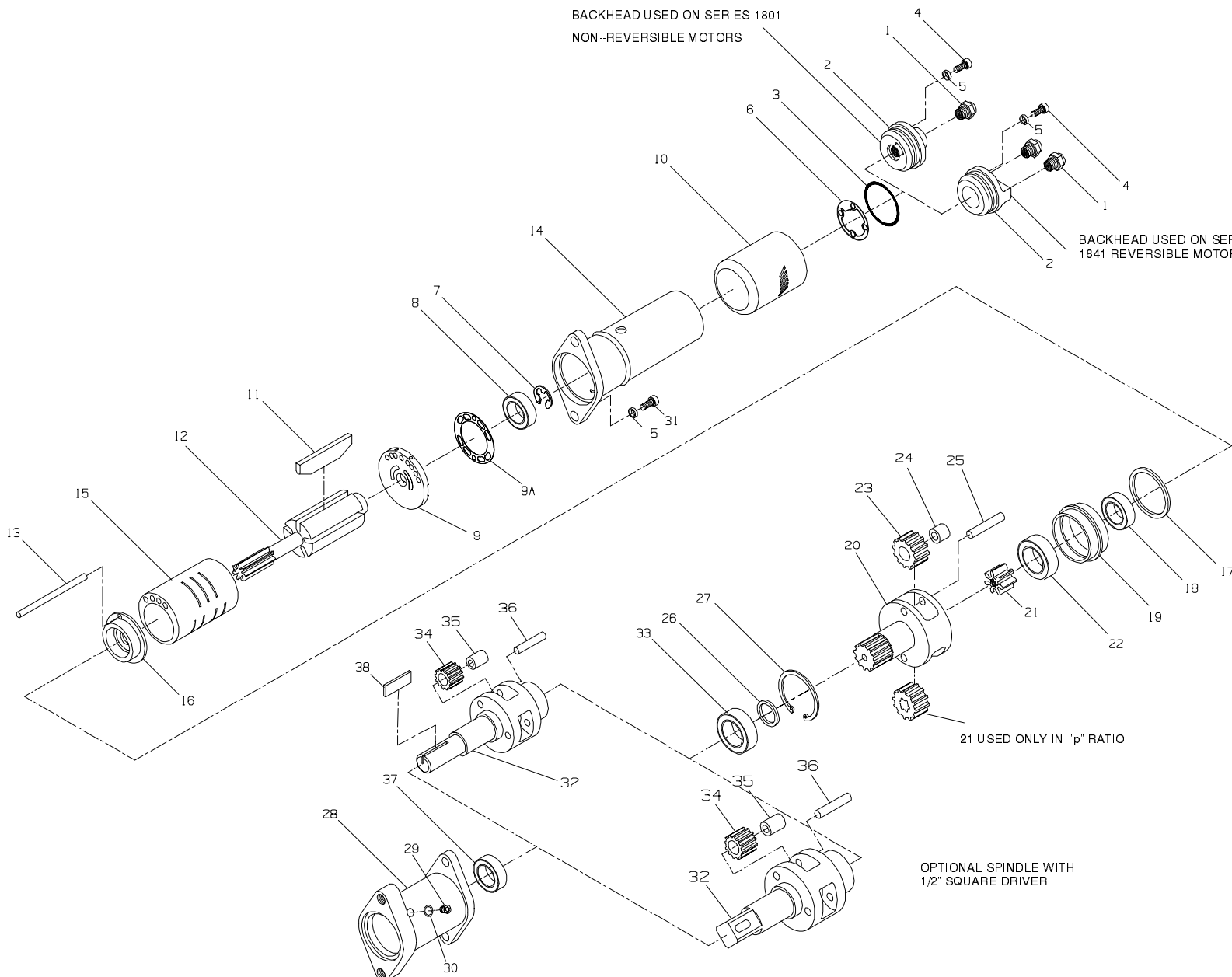

PART NUMBER FOR ORDERING

PART NUMBER FOR ORDERING

1	Air Strainer (1 for Series 1801; 2 for Series 1841) . .	R18-465A	• 16	Front End Plate . . . . .	R1801-11
2	Backhead		• 17	End Plate Gasket . . . . .	R1801-739
	for Series 1801 . . . . .	R1801-102	• 18	Front Rotor Bearing . . . . .	R1-24A
	for Series 1841 . . . . .	R1841-102	19	Bearing Cage . . . . .	R1801-113
• 3	Exhaust Deflector Seal . . . . .	R10V-310		Gear Head Assembly	
4	Backhead Cap Screw (2) . . . . .	510-638		for Model 1801P or 1841P . . . . .	R1801P-A216
5	Lock Washer (4) . . . . .	8U-58		for Model 1801Q or 1841Q . . . . .	R1801Q-A216
• 6	Backhead Gasket			for Model 1801U or 1841U . . . . .	R1801U-A216
	for Series 1801 . . . . .	R1801-283		for Model 1801W or 1841W . . . . .	R1801W-A216
	for Series 1841 . . . . .	R1841-283	20	Gear Head	
• 7	Rotor Bearing Retainer . . . . .	404-118		for Model 1801P or 1841P . . . . .	R1801P-216
• 8	Rear Rotor Bearing . . . . .	R1-24		for Model 1801Q or 1841Q . . . . .	R1801Q-216
• 9	Rear End Plate . . . . .	R1801-12A		for Model 1801U or 1841U . . . . .	R1801U-216
• 9A	Rear End Plate Gasket . . . . .	R1802-740		for Model 1801W or 1841W . . . . .	R1801W-216
★ 10	Exhaust Deflector		21	Rotor Pinion (for Model 1801P or 1841P) . . . . .	R1801P-17
	Standard . . . . .	R1801-23	22	Gear Head Bearing . . . . .	4E-510
	with 3/4" pipe tap Exhaust Port		23	Gear Head Planet Gear (2)	
	(for piped-away exhaust) . . . . .	R1801-A123		for Model 1801P or 1841P (14 teeth) . . . . .	R1801P-10
*	Deflector Front Seal (used with			for Model 1801Q or 1841Q (19 teeth) . . . . .	R1801Q-10
	No. R1801-A123 Deflector) . . . . .	R10V-310		for Model 1801U, 1841U, 1801W	
• 11	Vane Packet (set of 5 Vanes) . . . . .	R1801-42-5		or 1841W (21 teeth) . . . . .	R1801Q-10
12	Rotor		24	Gear Head Planet Gear Bearing (2)	
	for Model 1801N, 1801P, 1801U,			for Model 1801Q, 1801U, 1801W,	
	1801W, 1841N, 1841P, 1841U			1841Q, 1841U or 1841W . . . . .	R1AL-654
	or 1841W . . . . .	R1801P-53	25	Gear Head Planet Gear Shaft (2) . . . . .	R1A-191
	for Model 1801Q or 1841Q . . . . .	R1801Q-53	26	Gear Head Spacer (all except N ratio) . . . . .	R1AP-80
13	Cylinder Dowel . . . . .	R18-98	27	Spindle Bearing Retainer (all except N ratio) . . . . .	R1AP-118
★ 14	Motor Housing . . . . .	R1801-40	28	Gear Case	
• 15	Cylinder			for Model 1801N or 1841N . . . . .	R1841N61-37
	for Series 1801 . . . . .	R1801-3		for all other models . . . . .	R1801P-37
	for Series 1841 . . . . .	R1841-3			

\* Not illustrated.

• To keep downtime to a minimum, it is desirable to have on hand certain repair parts. We recommend that you stock one (pair or set) of each part indicated by a bullet (•) for every four tools in service.

★ **IMPORTANT:** The complete size symbol stamped on these parts must be stated when ordering a replacement Motor Housing or Exhaust Deflector.

PART NUMBER FOR ORDERING

PART NUMBER FOR ORDERING

29	Grease Plug .....	R00A-95	33	Spindle Rear Bearing	
30	Grease Plug Washer .....	R3-92A		for Model 1801N or 1841N .....	4E-510
31	Gear Case Cap Screw (2) .....	G57T-634		for all other models .....	R1AP-97
	Spindle Assembly		34	Spindle Planet Gear (3)	
	for Model 1801N or 1841N			for Model 1801N or 1841N (21 teeth) . . .	R1801U-10
	(5/8" round shaft) .....	R1801N-A108		for Model 1801P, 1801Q, 1801U, 1841P,	
	for Model 1801P, 1801Q, 1801U			1841Q or 1841U (17 teeth) .....	R1801P-10
	1841P, 1841Q or 1841U			for Model 1801W or 1841W (19 teeth) . .	R1801W-9
	with 5/8" round shaft .....	R1801P-A108	35	Spindle Planet Gear Bearing Gear	
	with 1/2" square drive .....	R1801P-A8		(1 for each Gear) .....	R1AL-654
	for Model 1801W or 1841W		36	Spindle Planet Gear Shaft (3) .....	F02-15
	with 5/8" round shaft .....	R1801W-A108	37	Spindle Front Bearing .....	4UA9-593
	with 5/8" square drive .....	R1801W-A8	38	Spindle Key .....	555-410
32	Spindle				
	for Model 1801N or 1841N				
	(5/8" round shaft) .....	R1801N-108			
	for Model 1801P, 1801Q, 1801U,				
	1841P, 1841Q or 1841U				
	with 5/8" round shaft .....	R1801P-108			
	with 1/2" square drive .....	R1801P-8			
	for Model 1801W or 1841W				
	with 5/8" round shaft .....	R1801W-108			
	with 5/8" square drive .....	R1801W-8			

MAINTENANCE SECTION

## MAINTENANCE SECTION

### WARNING

Always use protective eyewear when performing maintenance on a motor or operating a motor.

Always turn off the air supply and disconnect the air supply line before installing, removing or adjusting any accessory on this motor or before performing any maintenance on this motor. Failure to do so could result in injury.

### DISASSEMBLY

#### General Instructions

1. Do not disassemble the motor any further than necessary to replace or repair damaged parts.
2. Do not press any needle bearing from a part unless you have a new needle bearing on hand for installation. Needle bearings are always damaged during the removal process.
3. When grasping a tool in a vise, always use leather-covered or copper-covered vise jaws to protect the surface of the part or motor and help prevent distortion. This is particularly true of threaded members and housings.
4. Do not remove any part which is a press fit in or on a subassembly unless the removal of that part is necessary for repairs or replacement.
5. When removing the Planet Gear Shafts (25 or 36), support the motor end of the assembly and press the Shafts out toward the motor end. The shaft holes through the web are slightly tapered so that the Shafts have a tighter fit in the front web.

#### Disassembly of the Motor

1. Unscrew and remove the Inlet Bushings (1) from the Backhead (2).
2. Thread a piece of pipe about 6" long having an external 3/8" pipe thread into one of the inlet bushing holes. Use the pipe to clamp the motor into a vise for disassembly and assembly procedures.
3. Using a 3/16" hex wrench, unscrew and remove the two Gear Case Cap Screws (31) and Lock Washers (5).
4. Separate the Gear Case (28) from the Motor Housing (14) and set the assembled Gear Case aside.
5. Grasp the pinion of the Rotor (12) and pull the assembled motor out of the Motor Housing (14). It may be necessary to gently tap the face of the Motor Housing with a plastic hammer to jar the assembly free.
6. Grasp the Cylinder (15) in one hand and using a plastic hammer, sharply rap the spline of the end of the spline on the end of the Rotor to remove the Front End Plate (16) and Front Rotor Bearing (18) which will free the Cylinder and Vanes (11). Remove the Cylinder Dowel (13).
7. Jar the Front Rotor Bearing out of the Front End Plate by bumping the End Plate on a wooden block.

8. Use a thin blade screwdriver to pry the Rotor Bearing Retainer (7) off the hub of the Rotor and remove the Rear Rotor Bearing (8), Rear End Plate Gasket (9A) and Rear End Plate (9).
9. Using a 3/16" hex wrench, unscrew and remove the two Backhead Cap Screws (4) and Lock Washers (5).
10. Remove the Backhead, Exhaust Deflector Seal (3) and Backhead Gasket (6) from the rear of the Motor Housing.
11. Slide the Exhaust Deflector (10) off the Motor Housing.

#### Disassembly of the Gearing

1. **For all Models except 1801N or 1841N**, grasp the Gear Head Bearing (22) and pull the assembled Gear Head (20) out of the Gear Case (28). Remove the Gear Head Spacer (26) from the spline shaft of the Gear Head.
2. **For all Models except 1801N or 1841N**, using a bearing puller, pull the Gear Head Bearing off the rear hub of the Gear Head.
3. **For all Models except 1801N or 1841N**, support the short hub end of the Gear Head on the table of an arbor press and press the Gear Head Planet Gear Shafts (25) from the Gear Head. Make certain the Shafts are pressed out toward the short hub because the holes in the Gear Head are tapered smaller toward the front of the Gear Head.
4. **For all Models except 1801N or 1841N**, remove the Gear Head Planet Gears (23) from the Gear Head.
5. **For Model 1801P or 1841P**, remove the Rotor Pinion (21).
6. **For all Models except 1801N or 1841N**, if the Gear Head Planet Gear Bearings or Bushings (24) must be replaced, press them from the Planet Gears.
7. **For all Models except 1801N or 1841N**, using internal snap ring pliers, remove the Spindle Bearing Retainer (27) from the inside of the Gear Case.
8. Holding the Gear Case, push the output end of the Spindle (32) to move the Spindle Assembly out the motor end of the Gear Case.
9. Using a bearing puller, pull the Spindle Rear Bearing (33) off the rear hub of the Spindle.
10. Using a bearing puller, pull the Spindle Front Bearing (37) off the front hub of the Spindle.
11. Support the short hub end of the Spindle on the table of an arbor press and press the Spindle Planet Gear Shafts (36) from the Spindle. Make certain the Shafts are pressed out toward the short hub because the holes in the gear frame of the Spindle are tapered smaller toward the output end of the spindle shaft.
12. Remove the Spindle Planet Gears (34) from the Spindle.
13. If the Spindle Planet Gear Bearings (35) must be replaced, press them from the Planet Gears.

## MAINTENANCE SECTION

### ASSEMBLY

#### General Instructions

1. Always press on the **inner** ring of a ball-type bearing when installing the bearing on a shaft.
2. Always press on the **outer** ring of a ball-type bearing when pressing the bearing into a bearing recess.
3. Whenever grasping a tool or part in a vise, always use leather-covered or copper-covered vise jaws. Take extra care not to damage threads or distort housings.
4. Except for bearings, clean every part and wipe every part with a thin film of oil before installation.
5. Check every bearing for roughness. If an open bearing must be cleaned, wash it thoroughly clean suitable solution and dry with a clean cloth. Sealed or shielded bearings should not be cleaned. Work grease into every bearing before installation.
6. Apply a film of O-ring lubricant to every O-ring before installation.
7. When installing the Planet Gear Shafts (25 or 36), support the spindle end of the assembly and press the Shafts in toward the spindle end. The shaft holes through the web are slightly tapered so that the Shafts have a tighter fit in the front web.
8. Unless otherwise noted, always press on the stamped end of a needle bearing when installing a needle bearing into a recess. Use a bearing inserting tool similar to the one shown in Dwg. TPD786.

#### NEEDLE BEARING INSERTING TOOL

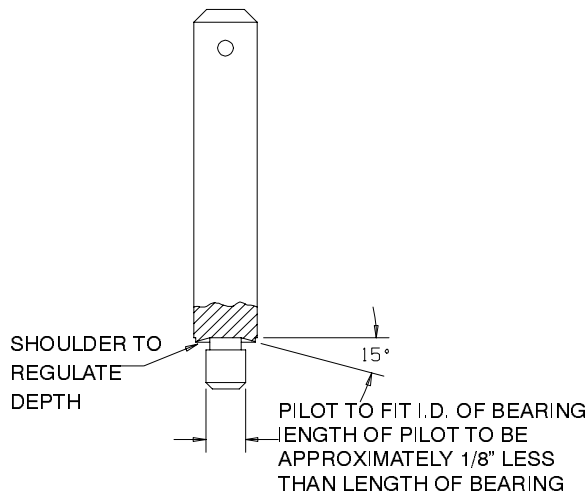

(Dwg. TPD786)

#### Assembly of the Gearing

1. If the Spindle Planet Gear Bearings (35) were removed from the Spindle Planet Gears (34), press new Bearings into the Gears using a needle bearing inserting tool. If any Gears are damaged, install a complete new set of Gears. Do not mix old Gears with new Gears in the same motor.

2. Support the web at the output end of the Spindle (32) on the table of an arbor press and position a Spindle Planet Gear with a Bearing in the web. The holes in the webs of the Spindle are tapered and smaller toward the output end of the Spindle. Press a Spindle Planet Gear Shaft (36) through the rear web and Bearing into the front web until the Shaft is flush with the face of the rear web.
3. Repeat Step 2 with the remaining Spindle Planet Gears and Bearings.
4. Stand the Spindle, output end upward, on the table of an arbor press and using a piece of tubing that will clear the Spindle, press the Spindle Front Bearing (37) onto the Spindle.
5. Invert the Spindle and without applying pressure to the Spindle Front Bearing, press the Spindle Rear Bearing (33) onto the short hub of the Spindle.
6. Apply lubricant to the gearing and shaft and insert the assembled Spindle, output end leading, into the end of the Gear Case (28) with the largest opening. Push the assembly into the Gear Case until the Spindle Front Bearing seats in the gear case bearing recess.
7. **For all Models except 1801N or 1841N**, use snap ring pliers to install the Spindle Bearing Retainer (27) in the groove inside the Gear Case.
8. **For all Models except 1801N, 1801P, 1841N or 1841P**, if the Gear Head Planet Gear Bearings (24) were removed from the Gear Head Planet Gears (23), press new Bearings into the Gears using a needle bearing inserting tool. If any Gears are damaged, install a complete new set of Gears. Do not mix old Gears with new Gears in the same motor.  
**For Models 1801P or 1841P**, if the Gear Head Planet Gear Bushings (24) were removed from the Gear Head Planet Gears (23), press new Bushings into the Gears. If any Gears are damaged, install a complete new set of Gears. Do not mix old Gears with new Gears in the same motor.
9. **For all Models except 1801N, 1801P, 1841N or 1841P**, support the web at the spline shaft end of the Gear Head (20) on the table of an arbor press and position a Gear Head Planet Gear with a Bearing in the web. The holes in the webs of the Gear Head are tapered and smaller toward the spline shaft end of the Gear Head. Press a Gear Head Planet Gear Shaft (25) through the rear web and Bearing into the front web until the Shaft is flush with the face of the rear web.  
**For Models 1801P or 1841P**, support the web at the spline shaft end of the Gear Head (20) on the table of an arbor press and position a Gear Head Planet Gear with a Bushing in the web. The holes in the webs of the Gear Head are tapered and smaller toward the spline shaft end of the Gear Head. Press a Gear Head Planet Gear Shaft (25) through the rear web and Bushing into the front web until the Shaft is flush with the face of the rear web.



## MAINTENANCE SECTION

10. **For Models 1801P or 1841P**, insert the Rotor Pinion (21) into the center of the Gear Head. This must be done before installing the second Gear in the Gear Head. It cannot be installed after a second Gear is secured in position.
11. **For all Models except 1801N or 1841N**, repeat Step 9 with the remaining Gear Head Planet Gear and Bearing or Bushing.
12. **For all Models except 1801N or 1841N**, stand and support the assembled Gear Head on the table of an arbor press with the spline shaft end downward and press the Gear Head Bearing (22) onto the hub of the Gear Head.
13. **For all Models except 1801N, 1801P, 1841N or 1841P**, slide the Gear Head Spacer (26) onto the spline shaft of the Gear Head.
14. **For all Models except 1801N or 1841N**, apply lubricant to the gear head gearing and while engaging the spline of the Gear Head with the gearing of the Spindle, slide the assembled Gear Head into the Gear Case.

### Assembly of the Motor

1. Position the Backhead Gasket (6) against the rear face of the Motor Housing (14).  
For Series 1801 Non-reversible Motors, position the Gasket to block off the holes in the quadrant marked with an "R" if forward rotation is desired, or to block off the holes in the quadrant with an "F" if reverse rotation is desired.  
For Series 1841 Reversible Motors, position the Gasket so that the gasket material dividing the central opening separates the forward quadrant marked with an "F" from the reverse quadrant marked with an "R."
2. Install the Exhaust Deflector Seal (3) in the annular groove that encircles the Backhead (2).
3. Slide the Exhaust Deflector (10), large opening end trailing, over the Motor Housing.
4. Place the Backhead against the Gasket making sure the Exhaust Deflector slips over the Exhaust Deflector Seal without nicking or damaging the Seal. Install the two Backhead Cap Screws (4) and Lock Washers (5) to secure the Backhead and Exhaust Deflector to the Motor Housing.
5. Thread a 6" long piece of pipe with a 3/4" external pipe thread into the Backhead and grasp the pipe in vise jaws with the Motor Housing upward.
6. Insert the Rear End Plate Gasket (9A) into the motor bore opening of the Motor Housing and move it to the bottom of the opening. Make certain the dowel holes in the Gasket align with the Cylinder Dowel holes in the bottom of the motor bore.
7. Push the Rear End Plate (9), flat face leading, onto the short hub of the Rotor (12).
8. Push the Rear Rotor Bearing (8) onto the short hub of the Rotor against the Rear End Plate and install the Rear Rotor Bearing Retainer (7) in the groove on the shaft of the Rotor to retain the Bearing.
9. Place a Vane (11) in each vane slot in the Rotor and place the Cylinder (15) down over the Rotor and Vanes and against the Rear End Plate. Make certain the holes in the Cylinder and End Plate can be aligned. If they can't, invert the Cylinder.
10. Press the Front Rotor Bearing (18) into the Front End Plate (16).
11. Press the Front Rotor Bearing, Front End Plate leading, onto the spline end of the rotor shaft until the End Plate contacts the Cylinder.
12. Use a 1/8" rod approximately 9" long to align the cylinder dowel holes in the Front End Plate, Cylinder and Rear End Plate. Insert the end of the rod at the Rear End Plate end through the dowel hole in the Rear End Plate Gasket and into the dowel hole in the Motor Housing. Slide the assembled motor along the rod into the Motor housing until it bottoms against Gasket.
13. Remove the assembly rod and install the Cylinder Dowel (13) in its place.
14. Install the End Plate Gasket (17) over the hub of the Front End Plate.
15. Install the Bearing Cage (19), end nearest the largest outer hub trailing, over the rotor shaft and into the Motor Housing against the End Plate Gasket.
16. Install the assembled Gear Case against the Motor Housing. It may be necessary to rotate the Spindle by hand to properly engage the gearing with the spline on the Rotor.
17. Secure the Gear Case to the Motor Housing with the two Gear Case Cap Screws (31) and Lock Washers (5).
18. Remove the assembled motor from the vise jaws and unscrew and remove the assembly pipe from the Backhead. Install the Air Strainer (1) (two for reversible models) in the Backhead.

### NOTICE

**SAVE THESE INSTRUCTIONS.  
DO NOT DESTROY.**

## ***NOTES***

## ***NOTES***