

OPERATION AND MAINTENANCE MANUAL

for

GEARED AIR MOTORS

MODELS E3G, EE3G, EEU3G, EE9G and EEU9G (Four Cylinder)

MODELS EE53G, EE5U3G, EE59G and EE5U9G (Five Cylinder)

CAUTION: Lubricate the Motor before putting it in service. To prevent leakage during shipment, the oil was drained from the Motor Case (1). Sufficient oil for one filling is contained in the can packed with the Motor. Before operating the Motor, unscrew the Vent Cap (4) and pour the entire contents of the can into the Motor Case.

LUBRICATION

Motor

Check the oil level daily.

When the Motor is not subjected to freezing temperatures: After the Motor has been idle for several hours or overnight, open the Oil Cock (2) located at the bottom of the Motor Case (1) and allow the accumulated water to drain out. Close the Oil Cock at the bottom and open the one on the side of the Motor Case. Remove the Vent Cap (4) and pour a sufficient quantity of the recommended oil through this opening to bring the oil level up to the open Oil Cock. Close the Oil Cock and replace the Vent Cap.

When the Motor is subjected to freezing temperatures: Allow the Motor to remain idle long enough for the water content in the Motor Case (1) to separate from the oil, but not long enough for it to freeze. Drain the water and replenish the oil as above. Should this procedure be impractical, drain the entire contents from the Motor Case immediately after operation ceases, and pour the oil back into the Motor Case before resuming operation. If not drained, a sufficient quantity of water will eventually accumulate so that the Oil Splasher (15) attached to the Crank (10) will freeze fast.

For temperatures 30° to 80° F, use Ingersoll-Rand Pneu-Lube® Medium Oil No. 50.

For temperatures above 80° F, use SAE40 Motor Oil.

For temperatures below 30° F, use SAE 20 or 20W Motor Oil.

Weekly, insert a small quantity of Ingersoll-Rand Light Grease 28 into the Grease Fittings located in the Utility Hoist Type Valve Chest (100) or Control Block Valve Chest (204). Two or three strokes from the No. P25-228 Grease Gun are sufficient.

Ingersoll-Rand Air Line Lubricators are recommended for use with all Geared Motors.

Whenever the application permits, install a suitable Lubricator or Filter-Lubricator Unit in the air line. Always install the Unit as close to the Motor as practical, and adjust it to feed only enough oil to produce a slight mist in the exhausting air.

Gear Box

Periodically, as experience indicates, unscrew the Grease Level Plug (56) from the side of the Gear Box (54). If the grease level is below the opening, unscrew the Grease Plug (55) from the top of the Gear Box and add a sufficient quantity of the recommended grease to bring the grease level up to the side opening. For temperatures above 40° F, use Ingersoll-Rand Heavy Gear Grease No. 70. For temperatures below 40° F, use Ingersoll-Rand Medium Gear Grease No. 75.

AIR STRAINER

To clean the Air Strainer, shut off the air supply and unscrew the Air Strainer Plug (403 or 664) from the Strainer Cap (404 or 663). Turn on the air momentarily and blow out the dirt. If the Screen (401 or 662) becomes clogged to the extent that the above method fails to clean it properly, unscrew the Cap from the body of the Strainer (400 or 661), remove the Screen and wash it in kerosene or other solvent.

INSTALLATION

Mount the Motor by firmly fastening the foot pad on the Gear Box (54) to the floor or horizontal platform. **Caution:** Geared Motors should be mounted so that the axis of the Drive Shaft (73) is horizontal. Operation of the Motor with the axis of the Shaft more than 10° from horizontal will result in lubrication difficulties.

MAINTENANCE

Motor Disassembly

1. Drain the oil.
2. Remove the Motor Case (1) from the Gear Box (54).
3. Remove one Cylinder Head (21) and Cylinder Sleeve (21A) from the Motor. Rotate the Crank (10) until the Piston (25) from which the Cylinder was removed is at top dead center. Remove the Wrist Pin (28) and Piston from the Connecting Rod (17). Repeat until all Cylinders and Pistons have been removed.
4. The Crank is now held in place only by the fit of the Crank Bearing (20) in its recess and can usually be removed by pulling on it with one hand while tapping the face of the Motor Case (1) with a soft hammer. If this method fails to loosen the Bearing, remove the Rotary Valve (see paragraph 5). Insert a brass rod or hardwood arbor through the bore of the Rotary Valve Bushing (30, 102 and 151) and drive on the rod until the Crank Assembly is loosened.
5. Remove the Valve Chest Cover (35, 119 or 162) from the Valve Chest (29, 100 or 150) and withdraw the Rotary Valve (33, 110 or 156) with a bolt screwed into the tapped hole in the end of the Valve. Valves for four-cylinder Motors are tapped 3/4"-10 thd.; for five-cylinder Motors they are tapped 7/8"-9 thd.

Notice: The use of other than genuine Ingersoll-Rand replacement parts may result in decreased Motor performance and increased maintenance, and may invalidate all warranties.

Refer All Communications to the Nearest
Ingersoll-Rand Office or Distributor.

© Ingersoll-Rand Company 1987

Printed in U.S.A.

INGERSOLL-RAND®

AIR MOTORS

- Use two Jack Bolts to remove the Valve Chest from the Motor Case. Jack Bolts may be purchased from Ingersoll-Rand or made to the dimensions shown in the following illustration.

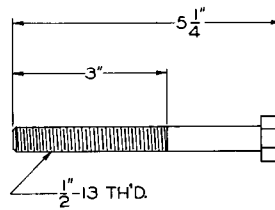

Valve Chest Jack Bolts

(Dwg. TPD1090)

- Support the face of the Valve Chest that contacts the Motor Case and with a suitable arbor that will clear the Bushing Key (32, 101 or 154), press the Rotary Valve Bushing (30, 102 or 151) and Reverse Valve Bushing (104) from the Valve Chest.

Crank Disassembly

- Loosen the Crank Pinch Bolt (13), straighten the split end of the Crank Taper Pin (12) and drive it out of the Crank (10).
- Separate the two sections of the Crank and remove the Connecting Rod Rings (18), Connecting Rods (17), Connecting Rod Bushing (19) and Crank Pin Sleeve (11).
- Pry the Crank Bearing (20) from each section of the Crank, only if replacement is necessary.

Crank Assembly

Note: The two sections of the Crank are matched before final machining, and the web of each section is tamped with an identification mark as "AA17", "CC21", "XX19", etc. Only sections bearing identical markings can be used together. Therefore, if two or more Cranks are disassembled at one time, check the web of each section before reassembly to make sure that only matched parts are assembled together.

- Slide the Crank Pin Sleeve (11), plain end first (there is a tang on one end), over the crank pin.
- Slide the Connecting Rod Bushing (19) over the Sleeve.
- Place one Connecting Rod Ring (18), radius end last, over the Bushing.
- Place the Connecting Rods (17) around the Bushing, entering the foot of each Rod into the space between the Bushing and the Ring.
- Slide the second Ring, radius end first, over the feet of the Rods.
- Join the two sections of the Crank, so that the tang on the Crank Pin Sleeve enters the slot in the Crank web, and the holes for the Crank Taper Pin or Crank Lock Pin are signed.
- Use a new Crank Taper Pin (12) each time a Crank is reassembled. Drive in into the aligned holes in the two crank sections, tighten the Crank Pinch Bolt (13) and spread the split end of the Crank Taper Pin.
- Using a sleeve that contacts only the inner ring of the Bearing, press a Crank Bearing (20) onto each end of the Crank. Press Bearings on until the inner ring contacts the shoulder.

Valve Chest Assembly

Note: All Rotary Valve Bushings and Reverse Valve Bushings are properly sized at the factory and, if carefully installed, reaming after installation is seldom necessary.

If the Rotary Valve (33, 110 or 156) fits too tightly in the Rotary Valve Bushing after installation, lap it to a good running fit using a mild, fine grain compound whose abrasive agent will rapidly disintegrate.

The Reverse Valve (112 or 209) is chrome-plated and should not be lapped. If it fits too tightly in the Reverse Valve Bushing (104 or 208), ream the Bushing 1.625" or 41.27 mm.

- For Utility Hoist Type Valve Chest**, support the face of the Valve Chest (100) that contacts the Valve Chest Cover (119), align the slot in the Reverse Valve Bushing (104) with the Bushing Key and press the Bushing in flush with the supported face of the Chest. Ream the hole through the wall of the Bushing .505" or 12.82 mm. Check fit between Reverse Valve and Bushing; if too tight, ream Bushing to proper size as stated above.
- For all types of Valve Chest**, support the face of the Valve Chest (29, 100 or 150) that contacts the Valve Chest Cover (35, 119 or 162), align the slot in the Rotary Valve Bushing (30, 102 or 151) with the Bushing Key (32, 101 or 154) and press the Bushing into the Chest until its leading face is flush with the supported face of the Chest. Check fit between Valve and Bushing. See Note above if Valve is too tight in Bushing.
- For Shuttle Valve Chest**, press a Shuttle Valve Bushing (153) into each end of the shuttle valve bore, until the trailing face of each Bushing is 2-1/16" or 52.4 mm deep and ream them 1.187" or 30.2 mm. Ream through both Bushings to obtain accurate alignment.
- For Utility Hoist Type Valve Chest**, rotate the Reverse Valve in the Reverse Valve Bushing until the arrows on the two parts align. Insert the Throttle Valve Ball (113), Throttle Valve (114) and Throttle Valve Spring (115) into the Chest and apply the Throttle Valve Cap (117). Install the Throttle Lever Spring (127) so that its coil encircles the protruding end of the Reverse Valve Bushing and its legs straddle the Throttle Spring Stop Pin (107) which protrudes from the Chest. Install the Throttle Control Arm (124) by slipping the square socket in the Arm over the square shank on the Reverse Valve and entering the Stop Pin (125) between the spring legs.

Motor Assembly

- Support the open face of the Motor Case (1). Start the end of the Rotary Valve Bushing that protrudes from the Valve Chest squarely into the bushing bore of the Motor Case, aligning the bolt holes in the Chest with the tapped holes in the Motor Case. Press on Bushing until the Valve Chest contacts the Motor Case.
- Install the Crank assembly in the Motor Case, seating the Crank Bearing in the recess in the Case.
- Rotate the Crank until one of the Connecting Rods (17) is at top dead center, place a Piston (25) on this Rod and retain with a Wrist Pin (28).
- Place a Cylinder Gasket (22) over the skirt and against the flange of one Cylinder Sleeve (21A).
- Slide the Cylinder Sleeve over the Piston and into the Motor Case. **Note:** The Piston Ring (26) (compression ring near the top of the Piston) can be compressed sufficiently with the fingers to enter it into the Cylinder Sleeve. It is also possible to start the Oil Regulating Ring (27) with the fingers, but is very difficult and there is danger of breaking the Ring if it is not uniformly started in the Cylinder Sleeve. It is recommended that a Piston Ring Compressor be used. One can be purchased from Ingersoll-Rand (see Maintenance Tools) or one can be made from 1/16" or 1.58 mm spring steel about 3/4" or 19 mm wide bent into circular shape of such size that it can be slipped over the Piston to hold the Ring compressed into its groove.
- Install the Cylinder Head (21) and Cylinder Sleeve. Retain the Cylinder Head in position with the Cylinder Ring Cap Screws (23) using a Cylinder Cap Screw Washer (24) (copper washer) under the head of each Cap Screw. Repeat until all Cylinder Assemblies are installed.
- Align the Large Valve Drive Pin (34, 111 or 157) that protrudes from the end of the Rotary Valve with the large drive hole in the Crank and insert the Valve into the Bushing, entering the Pin in the hole. **Note:** The Rotary Valve (33, 110 or 156) in five-cylinder Motors is fitted with two Small Valve Drive Pins in addition to the Large Valve Drive Pin. Cranks for the above Motors are drilled with two additional holes to receive the small Pins.
- Install the Valve Chest Cover or Shuttle Valve Chest Cover.

Gear Box Disassembly

1. Drain the oil from the Motor Case (1) and the grease from the Gear Box (54).
2. Remove the motor assembly from the Gear Box.
3. Screw a 3/8"-16 thd. cap screw into each of the two tapped holes located on the bolt circle of the Motor Case Cover (50) to jack the Cover from the Gear Box.
4. When removing the Drive Shaft (73) and gearing in Model E3G, EE3G, E53G or EE53G, lightly strike the end of the Drive Shaft with a soft hammer; for other models pry on the Drive Gear (72) and Intermediate Gear (62) so that both Gears and their assembled parts are removed simultaneously.
5. Before attempting to press the Drive Shaft (73) out of the Drive Gear (72), loosen the Drive Gear Screw (68) in the gear hub.

Gear Box Assembly

Note: At one time the Drive Shaft Inner Bearing (70) was a radial-thrust type ball bearing on which the outer ring on one side is marked "Thrust Here". When reassembling a Drive Shaft unit, inspect the Inner Bearing and, if it is so marked, install it **unmarked side first** on the Shaft. Unless the Bearing is marked, it can be installed either side first. Replacement Bearings furnished by Ingersoll-Rand will not be the radial-thrust type.

1. After installing the Drive Gear (72) on the Drive Shaft (73) in Models EE9G or EE59G, securely tighten the Drive Gear Setscrew (68) located in the gear hub.
2. Lock the Bearing Screws (76) with a punch after tightening them securely in the Drive Shaft (73) and Intermediate Gear Shaft (63).
3. Install the Motor Pinion Bearing (60) and Motor Pinion (58) before installing the Drive Shaft (73) with assembled parts in the Gear Box.
4. Install the Drive Gear (72) with assembled parts and the Intermediate Gear (62) with assembled parts as a unit in the Gear Box (54) of Model EE9G or EE59G.
5. Insert the Motor Pinion Spacer (59) into the central hole in the Motor Case Cover (50) being careful not to dislodge or damage the felt Motor Pinion Packing (61). Allow the Spacer to protrude approximately 1" or 25 mm out of the flat side of the Cover.
6. Put five pounds of the recommended Gear Grease in the Gear Box.

ROTARY VALVE

Equipped with the standard Rotary Valve, the Drive Shaft (73) in Nonreversible Model E3G or E53G rotates **clockwise** when facing the outboard end; in Model E59G it rotates **counterclockwise**. If operation in the opposite direction is required, order EM-526R Rotary Valve for Model E3G. Order E5M-526RA Rotary Valve for Model E53G or E59G.

Equipped with the standard Rotary Valve, Reversible Geared Motors give equal performance in both directions of rotation.

When greater speed and power in the **clockwise** direction of rotation for Model EE3G, or **counterclockwise** direction for Model EE9G are desired, order Rotary Valve No. D10-526.

When greater speed and power in the **counterclockwise** direction of rotation are desired for Model EE3G, or **clockwise** direction for Model EE9G are desired, order D20-526 Rotary Valve.

When greater speed and power in the **clockwise** direction of rotation are desired for Model EE53G, or **counterclockwise** direction for Model EE59G are desired, order No. D10-526-5 Rotary Valve.

When greater speed and power in the **counterclockwise** direction of rotation are desired for Model EE53G, or **clockwise** direction for Model EE59G are desired, order EEUD-526A Rotary Valve.

Motor Assemblies, Shuttle Valve Chest Assemblies, and Utility Hoist Type Valve Chest Assemblies are furnished with the standard Rotary Valve unless otherwise specified.

MOTORS WITH UTILITY HOIST TYPE VALVE CHEST

The standard Motor Assembly includes the Valve Chest and Throttle parts illustrated in the drawings and listed in the foregoing part list. The Utility Hoist Type Valve Chest Assembly, illustrated on page 7, is available for Reversible Geared Motors and will be incorporated when specified in the Motor Assembly furnished as a replacement.

A Reversible Geared Motor with Utility Hoist Type Valve Chest is designated as Model EEU3G, EEU9G, EE5U3G or EE5U9G. It is furnished with a Throttle Lever (126) unless Pull-Chain control is specified.

MAINTENANCE TOOLS

TOOL NUMBER FOR ORDERING	TOOL NAME FOR ORDERING	OPERATION
P25-228	Grease Gun (for Motors with Utility Hoist Type Valve Chest or Remote Control)	Inserting grease into the Grease Fittings in the Utility Hoist Type Valve Chest and Remote Control Block.
D02-932	Valve Chest Jack Bolt (2 required)	Removing the Valve Chest (29), Utility Hoist Type Valve Chest (100) or Shuttle Valve Chest (150) from the Motor Case (1).
D10-933	Piston Ring Compressor	Compressing the Piston Ring (26 or 27) when installing a Cylinder (21).

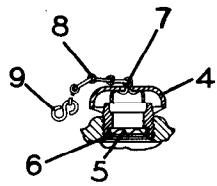

SECTION THRU VENT CAP

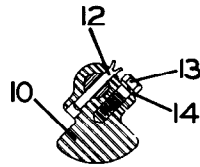

SECTION THRU CRANK

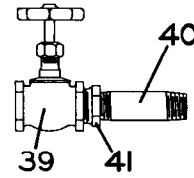

GLOBE VALVE AND NIPPLE

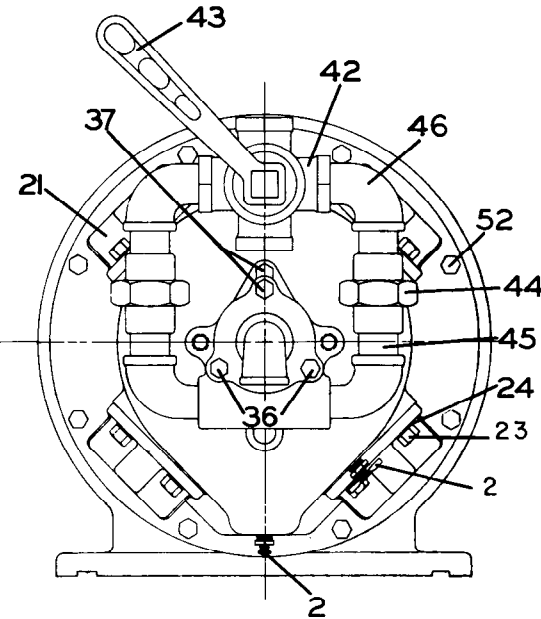
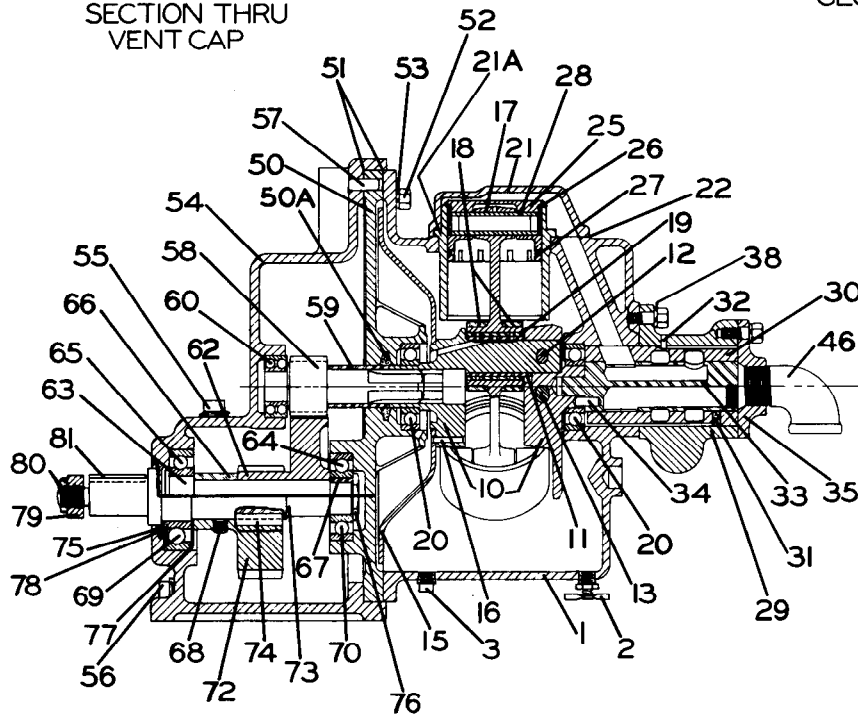

4

PART NUMBER FOR ORDERING

		FOUR-CYLINDER			FIVE-CYLINDER	
		Nonreversible Model E3G-W/V&P	Reversible Models EE3G and EE9G	Reversible Models EE3G-W/V&P EE9G-W/V&P EE9G70-W/V&P	Reversible Models EE53G & EE59G	Reversible Models EE53G-W/V&P EE59G-W/V&P EE59G71-W/V&P
	Motor Assembly (with standard Valve Chest; see footnotes ○ and †)	EM-A501	EEM-A501	EEM-A501	EE5M-A501	EE5M-A501
1	Motor Case	D10-501	D10-501	D10-501	E5UD-501	E5UD-501
2	Oil Cock (2)	D02-30B	D02-30B	D02-30B	D02-30B	D02-30B
3	Drain Plug	D02-402	D02-402	D02-402	T1SE-368	T1SE-368
*	1-1/4" Pipe Plug	---	---	---	E5UD-947	E5UD-947
4	Vent Cap	D02-303A	D02-303A	D02-303A	D02-303A	D02-303A
5	Vent Cap Screen	D02-889	D02-889	D02-889	D02-889	D02-889
6	Vent Cap Screen Retainer	6CND-233-1/2	6CND-233-1/2	6CND-233-1/2	6CND-233-1/2	6CND-233-1/2
7	Vent Cap Cotter	D02-893	D02-893	D02-893	D02-893	D02-893
8	Vent Cap Chain	D02-891	D02-891	D02-891	D02-891	D02-891
9	S-Hook	D02-421	D02-421	D02-421	D02-421	D02-421
10	Crank Assembly	D10-A516	D10-A516	D10-A516	E5M-A516	E5M-A516
	Crank (consists of two matched pieces not sold separately)	D10-516	D10-516	D10-516	D10-516	D10-516
● 11	Crank Pin Sleeve	D10-519	D10-519	D10-519	D10-519	D10-519
● 12	Crank Taper Pin	D10-520	D10-520	D10-520	D10-520	D10-520
13	Crank Pinch Bolt	D10-521	D10-521	D10-521	D10-521	D10-521
14	Crank Pinch Bolt Lock Washer	D10-322	D10-322	D10-322	D10-322	D10-322
15	Oil Splasher	D10-540	D10-540	D10-540	D10-540	D10-540
16	Oil Splasher Rivet (4)	D06-541	D06-541	D06-541	D06-541	D06-541
17	Connecting Rod (1 for each Cylinder)	D10-509	D10-509	D10-509	E5UD-509	E5UD-509
18	Connecting Rod Ring (2)	D10-510	D10-510	D10-510	D10-510	D10-510
● 19	Connecting Rod Bushing	D10-511	D10-511	D10-511	D10-511	D10-511
● 20	Crank Bearing (2)	D10-518	D10-518	D10-518	D10-518	D10-518
	Cylinder Assembly (4 for E3G, EE3G and EE9G; 5 for EE53 and EE59)	D10-A505A	D10-A505A	D10-A505A	D10-A505A	D10-A505A
21	Head	D10-H505A	D10-H505A	D10-H505A	D10-H505A	D10-H505A
21A	Sleeve	D10-L505A	D10-L505A	D10-L505A	D10-L505A	D10-L505A
● 22	Cylinder Gasket (1 for each Cylinder)	D10-507	D10-507	D10-507	D10-507	D10-507
23	Cylinder Cap Screw (4 for each Cylinder)	D10-506	D10-506	D10-506	D10-506	D10-506
24	Cylinder Cap Screw Washer (4 for each Cylinder)	D10-504	D10-504	D10-504	D10-504	D10-504
25	Piston Assembly (1 for each Cylinder)	D10-A513B	D10-A513B	D10-A513B	D10-A513B	D10-A513B
● 26	Piston Ring (1 for each Piston)	D10-337A	D10-337A	D10-337A	D10-337A	D10-337A
● 27	Oil Regulating Piston Ring (1 for each Piston)	D10-338	D10-338	D10-338	D10-338	D10-338
28	Piston Wrist Pin (1 for each Piston)	D10-514	D10-514	D10-514	D10-514	D10-514
29	Valve Chest	C10-545	C10-545	C10-545	E5M-545	E5M-545
30	Rotary Valve Bushing	D10-525AS	D10-525AS	D10-525AS	E5UD-525AS	E5UD-525AS
31	Rotary Valve Oiler	JA4-75	JA4-75	JA4-75	---	---
32	Rotary Valve Bushing Key	B12-255	B12-255	B12-255	B12-255	B12-255
○ 33	Rotary Valve (standard)	EM-526	EEG-526	EEG-526	EE5M-526A	EE5M-526A
34	Large Valve Drive Pin	D10-527	D10-527	D10-527	D10-527	D10-527
*	Small Valve Drive Pin (2)	---	---	---	D02-527	D02-527
35	Valve Chest Cover	C10-546	C10-546	C10-546	C10-546	C10-546
36	Valve Chest Long Screw (2)	D10-548	D10-548	D10-548	D10-548	D10-548
37	Valve Chest Short Screw (2)	D02-506	D02-506	D02-506	D02-506	D02-506
38	3/8" Lock Washer (4)	D02-321	D02-321	D02-321	D02-321	D02-321
39	Globe Valve	C10-283	---	---	---	---
40	Globe Valve Nipple	C04-285	---	---	---	---
41	Reducing Bushing	C10-284	---	---	---	---
42	Air Valve	C10-291	---	C10-291	---	C10-291
43	Air Valve Lever	C10-278	---	C10-278	---	C10-278
44	Union (2)	C10-282	---	C10-282	---	C10-282
45	Air Valve Nipple (4)	C10-286	---	C10-286	---	C10-286
46	Street Ell (5)	DU-587	---	DU-487	---	DU-587

* Not illustrated.

○ Refer to Rotary Valve on page 3.

† Refer to Motors with Utility Hoist Type Valve Chest on page 3.

● To keep downtime to a minimum, it is desirable to have on hand certain repair parts. We recommend that you stock one (pair or set) of each part indicated by a bullet (●) for every four tools in service.

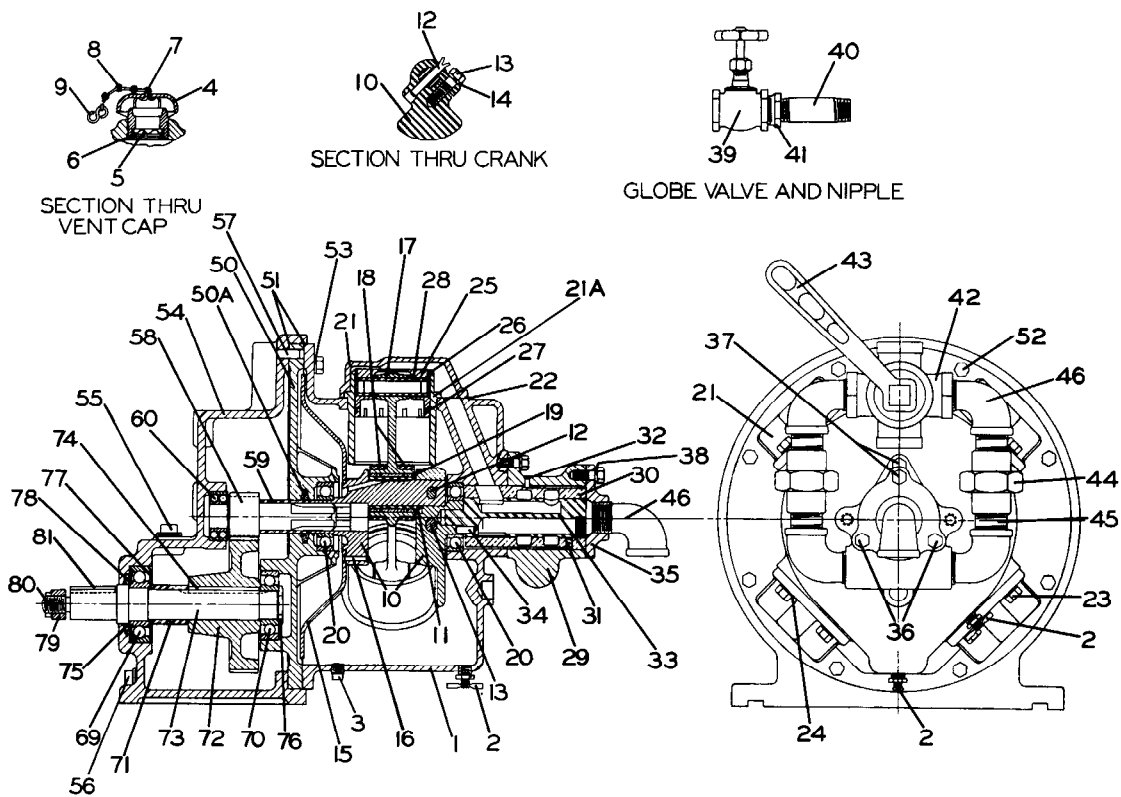

Model EE3G-W/V & P

(Dwg. TPB238-2)

PART NUMBER FOR ORDERING

		Models E3G, EE3G and EE53G	Models EE9G and EE59G
50	Motor Case Cover	E9G-751	E9G-751
50A	Motor Pinion Packing	EEG-755	EEG-755
• 51	Motor Case Cover Gasket (2)	D10-592	D10-592
52	Motor Case Screw (8)	D10-312	D10-312
53	3/8" Lock Washer (8)	D02-321	D02-321
54	Gear Box	E3G-750A	E9G-750
55	Grease Plug	22SR-165	22SR-165
56	Grease Level Plug or Drain Plug (2)	D02-351	D02-351
57	Motor Case Cover Dowel	D02-347	D02-347
58	Motor Pinion	EEG-752	EEG-752
59	Motor Pinion Spacer	EEUD-753	EEUD-753
• 60	Motor Pinion Bearing (Double Row, Narrow Type No. 520S Series Bearing)	D02-318	D02-318
62	Intermediate Gear	---	E9G-364
63	Intermediate Gear Shaft	---	E9G-365
• 64	Intermediate Gear Inner Bearing	---	21S-55
• 65	Intermediate Gear Outer Bearing	---	21S-63
66	Intermediate Shaft Bearing Spacer	---	E9G-369
67	Bearing Liner	---	E9G-35
68	Drive Gear Setscrew	---	HU-842
• 69	Drive Shaft Outer Bearing	E3G-763	HU-359
• 70	Drive Shaft Inner Bearing	21S-55	21S-55
71	Drive Shaft Bearing Spacer	E3G-761	---
72	Drive Gear	E3G-756	E9G-756
73	Drive Shaft	E3G-757	E9G-757A
74	Drive Gear Key	E3G-758	E9G-758
75	Drive Shaft Packing	E3G-759	E9G-759
76	Bearing Screw (2 for Models EE9G and EE59G; 1 for others)	E9G-769	E9G-769
77	Oil Washer	E3G-770	E9G-770
78	Packing Washer	E3G-780	E9G-780
79	Drive Shaft Nut	C620C40-305	C620C40-305
80	Drive Shaft Nut Cotter	D02-330	D02-330
81	Drive Shaft Key	EEG-768	RSSM-410

• To keep downtime to a minimum, it is desirable to have on hand certain repair parts. We recommend that you stock one (pair or set) of each part indicated by a bullet (•) for every four tools in service.

UTILITY HOIST TYPE VALVE CHEST PARTS
 Motors Equipped With Utility Hoist Type Valve Chest Are Designated
 As Models EEU3G, EEU9G, EE5U3G or EE5U9G

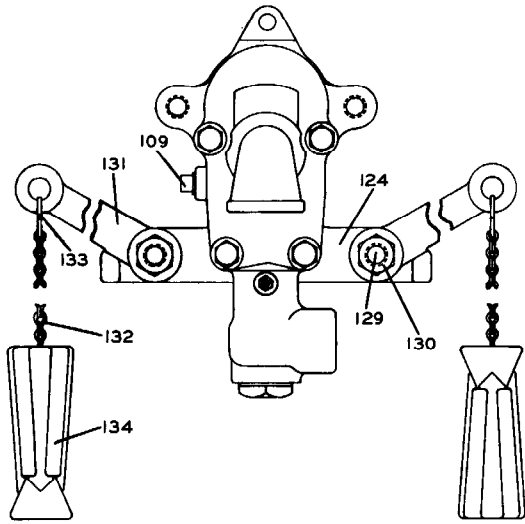

(Dwg. TPB240)

Utility Hoist Type Valve Chest with Pull Chain Throttle

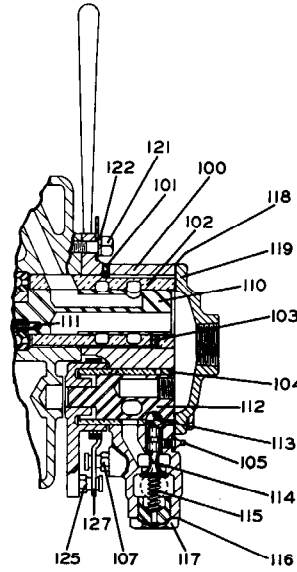

(Dwg. TPB241)

Utility Hoist Type Valve Chest with Lever Throttle

PART NUMBER FOR ORDERING

		Models EEU3G and EEU9G	Models EE5U3G and EE5U9G
○	Utility Hoist Type Valve Chest Assembly (with standard Rotary Valve)	EEUM-A545	EE5UM-A545
100	Utility Hoist Type Valve Chest.	D10-545A	D10-545-5
101	Bushing Key (2)	B12-255	B12-255
102	Rotary Valve Bushing.	D10-525A	E5UD-525A
103	Valve Oiler.	JA4-75	---
104	Reverse Valve Bushing	D10-945	D10-945-5
105	Small Grease Fitting.	R1-188	R1-188
106	Grease Fitting (2)	23-188	23-188
107	Throttle Spring Stop Pin.	D02-553	D02-553
108	Air Inlet Plug	22SR-165	22SR-165
109	1/4" Pipe Plug	D02-402	D02-402
○ 110	Rotary Valve (standard)	EEG-526	EE5M-526A
111	Large Valve Drive Pin.	D10-527	D10-527
*	Small Valve Drive Pin (2)	---	D02-527
112	Reverse Valve.	EU-944	EU-944
113	Throttle Valve Ball	D10-280	D10-280
114	Poppet Throttle Valve	D02-940	D02-940
115	Throttle Valve Spring.	B01-11	B01-11
116	Throttle Valve Cap Gasket	G601-411	G601-411
117	Throttle Valve Cap	D02-943	D02-943
● 118	Valve Chest Cover Gasket	D10-928	---
119	Valve Chest Cover	D10-546A	D10-546A
120	Valve Chest Long Screw (2).	D10-548	D10-548
121	Valve Chest Short Screw (3)	D02-506	D02-506
122	3/8" Lock Washer (5).	D02-321	D02-321
123	3/4" Street Ell	DU-581	---
124	Throttle Control Arm	D10-555	D10-555
125	Throttle Spring Stop Pin.	D02-553	D02-553
126	Throttle Lever	EU-556	EU-556
● 127	Throttle Lever Spring	D02-412B	D02-412B
128	Throttle Lever Guide.	DU-596	DU-596
129	Throttle Lever Bolt (2)	D02-411A	D02-411A
130	Throttle Lever Bolt Nut (2)	D02-418A	D02-418A
131	Pull Chain Throttle Lever (2)	D02-556	D02-556
132	Throttle Lever Chain (2) (12-1/2 ft. long unless other length is specified)	DU-413	DU-413
133	S-Hook (2 for each Chain).	D02-421	D02-421
134	Throttle Handle (2).	MR-415	MR-415

* Not illustrated.

○ Refer to Rotary Valve on page 3.

● To keep downtime to a minimum, it is desirable to have on hand certain repair parts. We recommend that you stock one (pair or set) of each part indicated by a bullet (●) for every four tools in service.

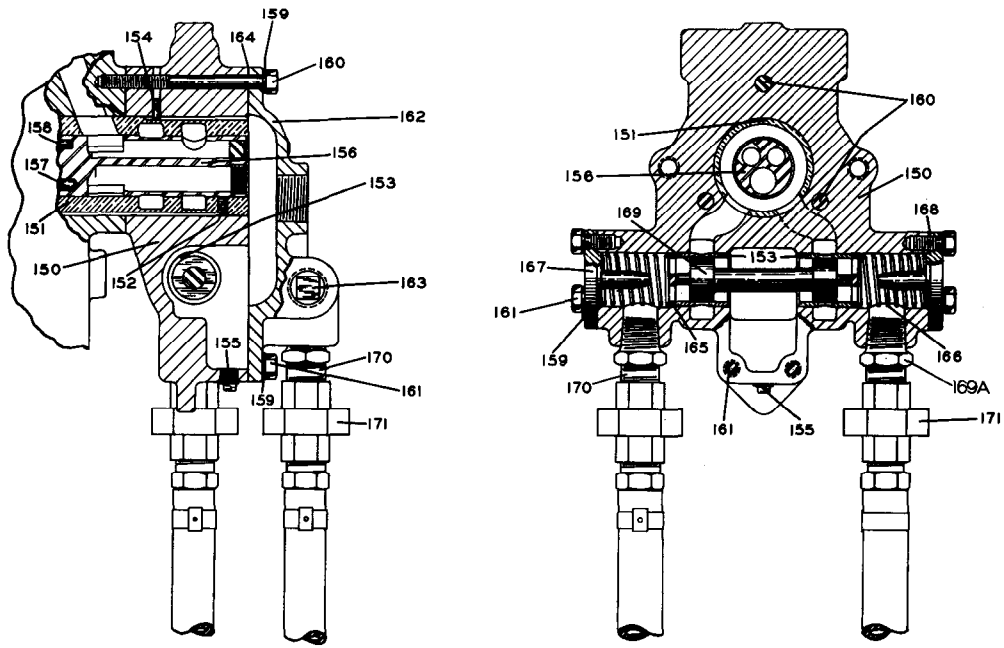

(Dwg. TPA230-1)

Shuttle Valve Chest Assembly

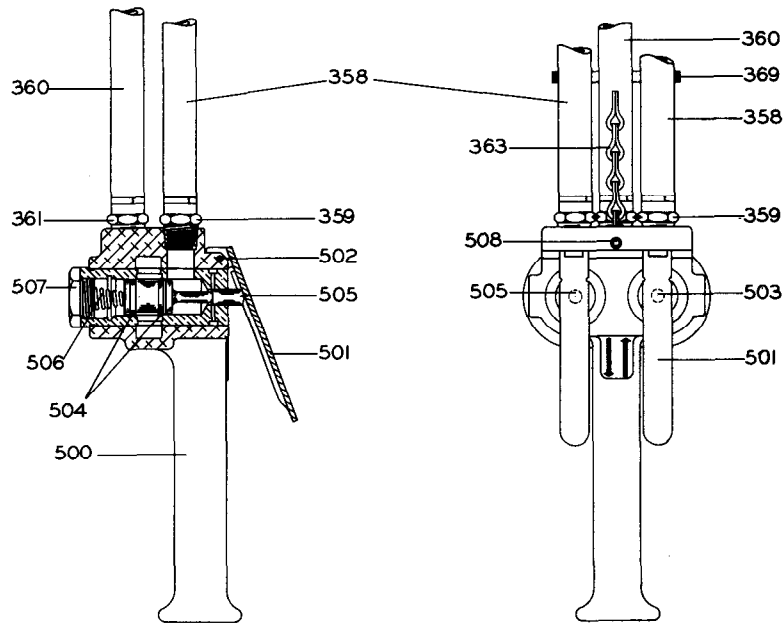

(Dwg. TPB412)

Pendent Throttle Handle

PENDENT THROTTLE PARTS FOR REVERSIBLE GEARED MOTORS

PART NUMBER FOR ORDERING

		↓	↓
		Models EE3G and EE9G	Models EE53G and EE59G
○	Pendent Throttle Conversion Unit (with standard Rotary Valve)	EEM-C245	EE5M-C245
○	Shuttle Valve Chest Assembly (with standard Rotary Valve)	EEM-A245	EE5M-A245
150	Shuttle Valve Chest	EEM-245	EE5M-245
151	Rotary Valve Bushing	D10-525AS	E5UD-525AS
152	Valve Oiler	JA4-75	— — —
153	Shuttle Valve Bushing (2)	D10-247	D10-247
154	Shuttle Valve Chest Bushing Key	ROAJ-191	B12-255
155	1/4" Pipe Plug	D02-402	D02-402
○ 156	Rotary Valve (standard)	EEG-526	EE5M-526A
157	Large Valve Drive Pin	D10-527	D10-527
158	Small Valve Drive Pin (2)	— — —	D02-527
159	3/8" Lock Washer (11)	D20-321	D02-321
160	Valve Chest Long Screw (3)	D10-548	D10-548
161	Valve Chest Short Screw (8)	D02-506	D02-506
162	Shuttle Valve Chest Cover	D10-241	EE5M-241
163	Valve Chest Cover Plug	22SR-165	22SR-165
164	Shuttle Valve Chest Cover Gasket	D10-236	D10-236
165	Shuttle Valve Washer (2)	D10-248	D10-248
166	Shuttle Valve Spring (2)	D10-250	D10-250
167	Shuttle Valve Cap (2)	D10-238	D10-238
168	Shuttle Valve Cap Gasket (2)	D10-239	D10-239
169	Shuttle Valve	EEM-246	EEM-246
169A	3/4" x 1/2" Reducing Bushing (3)	D02-420	D02-420
170	Pendent Throttle Inlet Nipple (3)	AAM-286	AAM-286
171	Control Hose Union (3)	AAM-282	AAM-282
358	Control Hose Assembly (2)		
	5 ft. length	C6H20A-A930	C6H20A-A930
	Length as specified	C6H20A-AL930	C6H20A-AL930
359	1/2" Male Hose Nipple (2 for each Hose)	C6H20A-14	C6H20A-14
360	Live Air Hose Assembly		
	5 ft. length	C6H20A-930	C6H20A-A930
	Length as specified	C6H20A-AL930	C6H20A-AL930
361	1/2" Male Hose Nipple (2 for each Hose)	C6H20A-14	C6H20A-14
363	Pendent Throttle Chain (length as specified)	D01-240	D01-240
369	Hose Binder (3)	D10-927	D10-927
500	Pendent Throttle Handle Assembly	EEM-A169	EEM-A169
501	Pendent Throttle Lever (2)	C6H20A-273	C6H20A-273
502	Throttle Lever Pin	C6H20A-281	C6H20A-281
503	Pendent Throttle Raise Valve Assembly	C6H20A-A164	C6H20A-A164
504	Pendent Throttle Valve Seal Ring (2)	AF160-289	AF160-289
505	Pendent Throttle Lower Valve Assembly	C6H20A-A164	C6H20A-A164
504	Pendent Throttle Valve Seal Ring (2)	AF160-289	AF160-289
506	Pendent Throttle Valve Spring (2)	T01-308	T01-308
507	Pendent Throttle Valve Cap (2)	C6H20A-180	C6H20A-180
508	Chain Anchor Pin Lock Screw	H54U-561	H54U-561
*	Throttle Chain Anchor Pin	R4-15	R4-15

* Not illustrated.

○ Unless otherwise specified, the standard Rotary Valve will be furnished with a Pendent Throttle Conversion Unit or Shuttle Valve Chest Assembly. Refer to Rotary Valve on page 3 for other Rotary Valves that are available and will be furnished when specified.

SUPERSEDED PENDENT THROTTLE PARTS FOR REVERSIBLE GEARED MOTORS

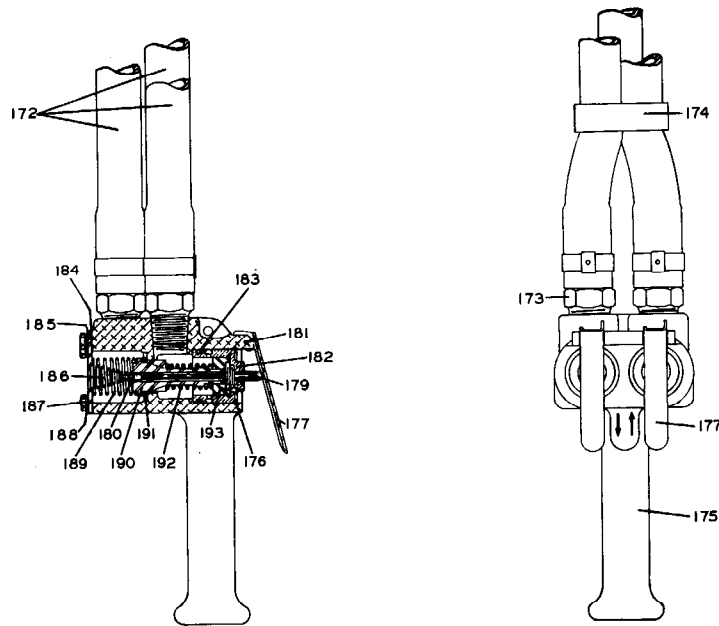

(Dwg. TPB239-1)

Pendent Throttle Handle

		PART NUMBER FOR ORDERING	
		↓	↓
		Models EE3G and EE9G	Models EE53G and EE59G
170	Pendent Throttle Inlet Nipple (3)	J3-840	J3-840
171	Control Hose Union (3)	C04-282	C04-282
172	Control Hose (3)		
	Standard length 7 ft.	EEM-930	EEM-930
	Length as specified	D10-L930	D10-L930
173	Control Hose Nipple (2 for each Hose)	J3-581	J3-581
174	Hose Binder (3)	D10-927	D10-927
175	Pendent Throttle Handle	D10-279	D10-279
176	Handle Bushing Retainer (2)	D10-227	D10-227
177	Pendent Throttle Lever (2)	R00H-273A	R00H-273A
179	Throttle Valve Stem (2)	D10-214A	D10-214A
180	Throttle Valve Stem Seal (1 for each Stem)	R000BR1C-283	R000BR1C-283
181	Throttle Lever Pin	DLC-1281	DLC-1281
182	Pendent Throttle Handle Bushing (2)	D10-225	D10-225
183	Handle Bushing Seal (1 for each Bushing)	D10-226	D10-226
184	Pendent Throttle Handle Cover Gasket	D10-219	D10-219
185	Pendent Throttle Handle Cover	D10-218	D10-218
186	Throttle Valve Stem Spring (2)	R2F-262	R2F-262
187	Pendent Throttle Handle Cover Cap Screw (7)	R3-7	R3-7
188	Throttle Handle Cover Cap Screw Lock Washer (7)	L01-67	L01-67
189	Pendent Throttle Valve Spring (2)	D10-213	D10-213
190	Pendent Throttle Valve (2)	D10-211	D10-211
191	Pendent Throttle Valve Face (1 for each Valve)	BU-948	BU-948
192	Bleed Valve Spring (2)	D10-275	D10-275
193	Bleed Valve (2)	D10-223	D10-223

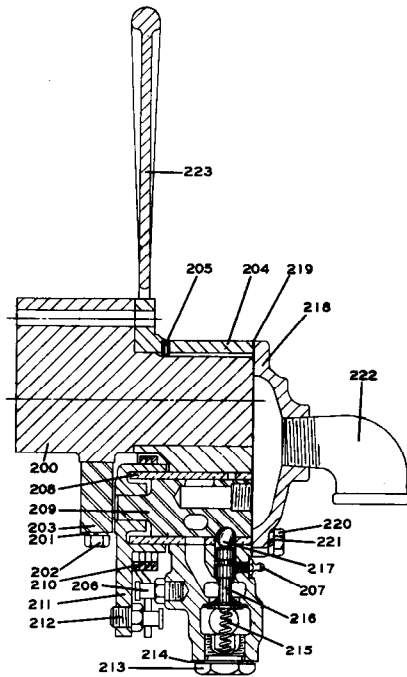

(Dwg. TPC175)

Remote Control Block Assembly

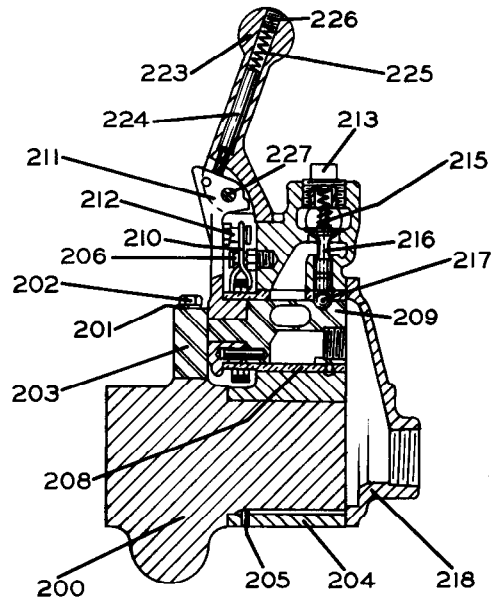

(Dwg. TPD201)

Remote Control Block Assembly

REMOTE CONTROL BLOCK PARTS FOR REVERSIBLE GEARED MOTORS

PART NUMBER FOR ORDERING

		Models EE3G and EE9G	Models EE53G and EE59G
	Remote Control Block Assembly	EU-A685	HU-A685
200	Remote Control Block	D10-685	HU-685
201	Control Arm Retainer Screw Lock Washer (2)	T11-58	D02-321
202	Control Arm Retainer Screw (2)	G7-7A	HU-865
203	Control Arm Retainer	D02-687	HU-687
204	Control Block Valve Chest	D10-876A	HU-876A
205	Bushing Key (2)	B12-255	HU-538
206	Throttle Spring Stop Pin	D02-553	D02-553
207	Small Grease Fitting	R1-188	---
*	Grease Fitting (2)	23-188	23-188
208	Control Block Reverse Valve Bushing	D10-945	HU-945
*	1/4" Pipe Plug	D02-402	D02-402
*	Air Inlet Plug	22SR-165	---
209	Control Block Reverse Valve	EU-944	HU-944
● 210	Control Block Throttle Lever Spring	D02-412B	HU-412
211	Control Block Throttle Arm	D10-555	HU-555A
212	Throttle Spring Stop Pin	D02-553	D02-553
213	Control Block Throttle Valve Cap	D02-943	HU-943
● 214	Control Block Throttle Valve Cap Gasket	G601-411	---
215	Control Block Throttle Valve Spring	B01-11	HU-942
216	Control Block Poppet Throttle Valve	D02-940	HU-940
217	Control Block Throttle Valve Ball	D10-280	D10-280
218	Control Block Valve Chest Cover	D10-546A	HU-546A
● 219	Control Block Valve Chest Cover Gasket	D10-928	---
220	Control Block Valve Chest Cover Screw (2)	D02-506	---
221	Valve Chest Screw Lock Washer (2)	D02-321	---
222	Exhaust Elbow	DU-587	---
223	Control Block Throttle Lever	EU-556	HU-556
224	Throttle Lever Latch	---	HU-869
225	Latch Spring	---	HU-567
226	Throttle Lever Setscrew	---	HU-842
*	Throttle Lever Bolt (2)	D02-411A	---
*	Throttle Lever Bolt Nut (2)	D02-418A	---
227	Throttle Lever Pin	---	HU-870
*	Throttle Lever Pin Cotter (2)	---	D02-524

* Not illustrated.

● To keep downtime to a minimum, it is desirable to have on hand certain repair parts. We recommend that you stock one (pair or set) of each part indicated by a bullet (●) for every four tools in service.

AIR STRAINER
 (For Models E3G, EE3G, EE9G, EEU3G, EEU9G, EE5U3G and EE5U9G)

PART NUMBER FOR ORDERING →

661	Air Strainer Assembly	EU-A267
662	Air Strainer Screen	P25-61A
663	Air Strainer Cap	P25-268
664	Air Strainer Plug	P25-536
*	Air Strainer Nipple (3/4" x 2") . .	D02-456

* Not illustrated.

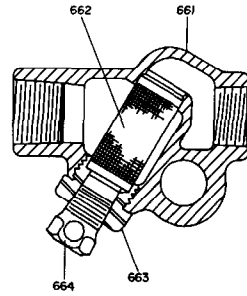

(Dwg. TPD1089)

AIR STRAINER
 (For Models EE53G and EE59G)

PART NUMBER FOR ORDERING →

400	Air Strainer Assembly	HU-A267AT
401	Air Strainer Screen	HU-61AT
403	Air Strainer Plug	D02-351
404	Air Strainer Cap	HU-268AT
*	Air Strainer Nipple (1" x 2") . . .	HHM-286

* Not illustrated.

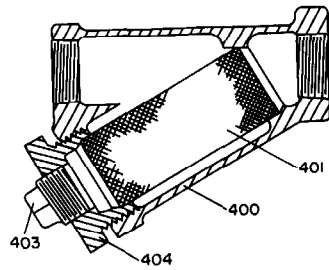

(Dwg. TPD122-1)