

INSTRUCTIONS AND REPAIR PART LIST

for

SERIES 92RM and 992RM MULTI-VANE[®] MOTORS

Form 6231
Third Edition
July, 1975

FOR OPERATION ON COMPRESSED AIR
Nonreversible Sizes 92RM1 and 92RM2
Reversible Size 992RM1

and

FOR OPERATION ON COMPRESSED GAS
Nonreversible Sizes 92RMG1 and 92RMG2
Reversible Size 992RMG1

IMPORTANT

Motors for operation on compressed gas incorporate special sealing to prevent gas leakage. This includes a Cylinder Seal (9) at each end of the Motor Housing (12), and an O-Ring type Gear Case Cover Seal (14) located in a groove in the Gear Case (13). These parts are not used on air operated Motors. Gas operated Motors also use a special Drive Shaft Grease Seal (20); **never use a substitute Seal.** NOTE: A Drive Shaft Grease Seal is included in the Gear Case Cover Assembly (19); therefore be sure to use the proper Assembly as listed in the part list section.

Motors for gas operation can be operated with compressed air, but Motors for air operation must never be operated with gas unless completely converted by the installation of the Cylinder Seals (9), Gear Case Cover Seal (20) and special Drive Shaft Grease Seal Part No. 150RMG14-271.

When installing one of these Motors, refer to the schematic diagram on Page 3.

GENERAL INFORMATION

Sizes 92RM1 and 92RM2 are identical except for the direction of rotation of the Drive Shaft; likewise Sizes 92RMG1 and 92RMG2. The direction of rotation is determined by the position of the Cylinder (8),

and can be changed by removing the Cylinder and turning it end for end.

Sizes 92RM1 and 92RMG1 are assembled at the factory so that the Drive Shaft rotates **clockwise** when facing its output end; Sizes 92RM2 and 92RMG2 are assembled for **counterclockwise** rotation.

LUBRICATION

Always use an air line lubricator with this Motor. We recommend Ingersoll-Rand No. NFLU-16 Filter Lubricator Unit. For temperatures above 30°F, use SAE 20 motor oil. For temperatures below 30°F, use SAE 10 or 10W motor oil. Set the lubricator valve to a medium feed or approximately 60 drops per minute.

After each 200 hours of operation, lubricate the gears and bearings with Ingersoll-Rand Lubricant No. 28, or a good No. 2 cup grease, as follows:

1. Remove the Gear Case Cover Cap Screws (28).
2. Grasp the Drive Shaft (26) and, as a unit, withdraw the Drive Shaft and Gear Case Cover.
3. Work some grease into both Drive Shaft Bearings (15) and the Front Rotor Bearing (23). Coat the teeth on the Drive Gear (17) and Rotor Pinion (22) with grease. Use grease sparingly. About one teaspoonful of grease should be sufficient for these members. *(Continued on Page 4)*

HOW TO ORDER

Order all repair parts for your Ingersoll-Rand Tool by the **NAME** and **NUMBER** shown in the Repair Part List section. **Never** use the illustration numbers which appear in the first column.

For prompt service and genuine Ingersoll-Rand parts, place orders with the nearest Ingersoll-Rand Branch Office.

Notice: The use of other than genuine Ingersoll-Rand replacement parts may result in decreased tool performance and increased maintenance, and may, at the Company's option, invalidate all warranties.

Refer All Communications to the Nearest
Ingersoll-Rand Branch Office or Distributor.

© Ingersoll-Rand Company 1975



Ingersoll-Rand

Ingersoll-Rand

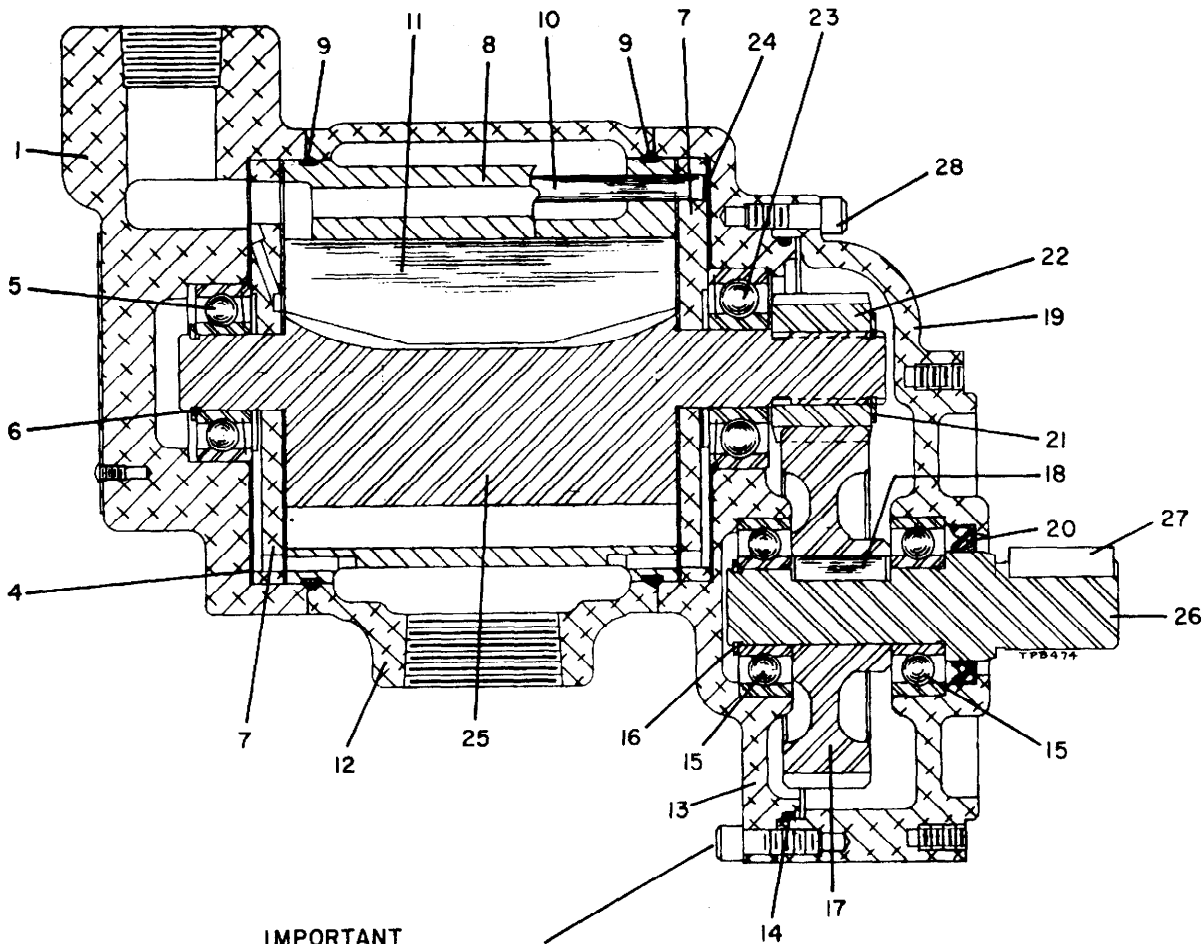

IMPORTANT
 WHEN INSTALLING THE GEAR CASE
 COVER, INSTALL THIS CAP SCREW
 (BOTTOM DEAD CENTER) FIRST

Series 92RM or 992RM Multi-Vane Motor

REPAIR PART LIST

ILLUSTRATION NUMBER (Do not use for ordering)	PART NAME FOR ORDERING (Parts indented after an item are included with that item)	PART NUMBER FOR ORDERING
1	Motor Housing Cover for 92RM1, 92RMG1, R2RM2 or 92RMG2 for 992RM1 or 992RMG1	92N-102 92R-102
*	Motor Housing Cover Short Cap Screw (2 for 992RM1 or 992RMG1; 4 for others)	12BMP-634
*	Motor Housing Cover Long Cap Screw (2) (for 992RM1 or 992RMG1)	107-25
*	Cap Screw Lock Washer (4) (Copper)	D02-504
● 4	Motor Housing Cover Gasket	10BM-283
● 5	Rear Rotor Bearing (AFBMA No. 20BC02JP)	92RMG10-22
6	Rear Rotor Bearing Retainer	R380Q-6
7	End Plate (2)	92RMG10-11
8	Cylinder for 92RM1 or 92RM2 for 992RM1	92RMG10-3 92R-3
8	Cylinder Assembly for 92RMG1 or 92RMG2 for 992RMG1	92RMG10-A3 92R-A3
● 9	Cylinder Seal (2) (for 92RMG1, 92RMG2 or 992RMG1)	92RMG10-103
10	Cylinder Dowel	205-1098
● 11	Vane Packet (Set of 5 Vanes)	R5H-42-5
12	Motor Housing	92N-40
13	Gear Case (for 92RM1, 92RM2 or 992RM1)	92RMG10-37
13	Gear Case Assembly (for 92RMG1, 92RMG2 or 992RMG1)	92RMG10-A37
● 14	Gear Case Cover Seal (for 92RMG1, 92RMG2 or 992RMG1)	92RMG10-607

* Not illustrated.

REPAIR PART LIST (Continued)

ILLUSTRATION NUMBER (Do Not Use For Ordering)	PART NAME FOR ORDERING (Parts indented after an item are included with that item)	PART NUMBER FOR ORDERING
15	Drive Shaft Bearing (2) (AFBMA No. 20BC02)	T02-33
16	Drive Shaft Retainer	R380Q-6
17	Drive Gear	92RMG10-9
18	Drive Gear Key	10BM-610
19	Gear Case Cover Assembly for 92RM1, 92RM2 or 992RM1 for 92RMG1, 92RMG2 or 992RMG1	92RM1-A478 92RMG10-A478
● 20	Drive Shaft Grease Seal for 92RM1, 92RM2 or 992RM1 for 92RMG1, 92RMG2 or 992RMG1	10BM-271 150RMG14-271
21	Rotor Pinion Retainer	10BM-69
22	Rotor Pinion	101BMPD-17
● 23	Front Rotor Bearing (AFBMA No. 20BC03JP)	555-24
● 24	Gear Case Gasket	10BM-284
25	Rotor	92RMG10-53
26	Drive Shaft Long (1.734"; 44 mm to shoulder) Short (1.250"; 32 mm to shoulder)	92RM1-8 92RMG10-8
27	Drive Shaft Key for 92RM1-8 for 92RMG10-8	107-54 205-61
28	Gear Case Cover Cap Screw (8)	510-638

IMPORTANT: When these motors are used on applications requiring a reversible motor, a 4-way throttle valve or two 3-way throttle valves must be used in the air supply line in accordance with the following schematic diagram. When the

application requires a nonreversible motor, a 2-way inline valve can be used in the air supply line. In either case, the inlet and outlet of the valve must be equal in size, and preferably one size larger, than the inlet of the motor.

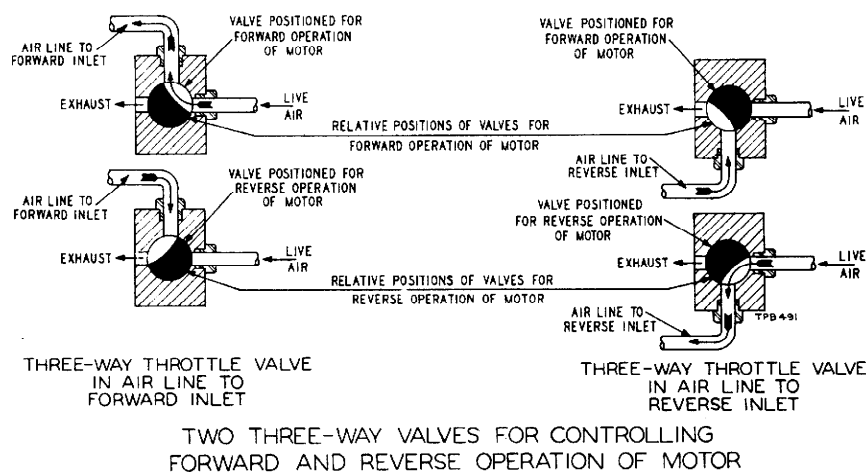
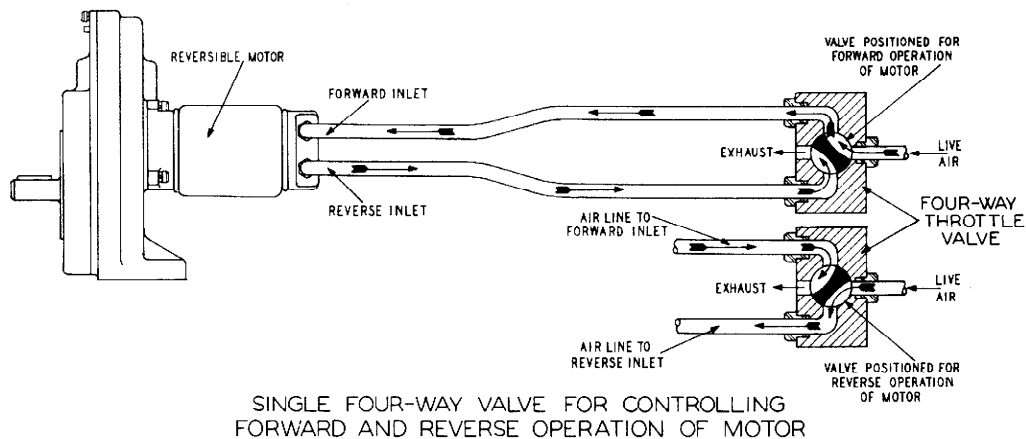

4. Replace the Gear Case Cover and Drive Shaft, and install the Gear Case Cover Cap Screws. Alternately tighten the Cap Screws to 20 ft-lbs (27.1 Nm) torque.

Important: Install the cap screw at bottom dead center first. Refer to note on the sectional view.

5. **Important:** For gas operated Motors, do not disassemble further unless you have two new No. 92RMG10-103 Cylinder Seals on hand.
6. Unscrew the Housing Cover Cap Screws (2) and withdraw the Motor Housing Cover (1). Try not to separate the joint between the Housing and Gear Case and do not change the location of the Housing relative to the Cylinder.
7. Work some grease into the Rear Rotor Bearing (5).
8. If you separated the Motor Housing from the Gear Case, or changed the location of the Housing relative to the Cylinder, carefully inspect the Cylinder Seals (9). If the Seals appear damaged in any respect, install new Seals.
9. Replace the Motor Housing Cover and install the Housing Cover Cap Screws. With the motor running at a slow speed (30 to 40 psig) (267 to 276 kPa) alternately tighten the Screws to 20 ft-lbs (27.1 Nm) torque.
10. Check the Motor for leaks by plugging the exhaust port and admitting 50 psig (345 kPa) of compressed air in the inlet. Apply soap suds or oil to the joint at each end of the Motor Housing and check for bubbles.
11. If the Motor leaks, check the tightness of the Housing Cover Cap screws. If this does not correct the trouble, install new Cylinder Seals (9).

Motor Assembly

Assemble the motor as follows:

1. Slip one End Plate (7), crescent groove side first, on the splined end of the Rotor (25).
2. Slide the Front Rotor Bearing (23) on the splined hub of the Rotor and against the End Plate.

3. Slide the Rotor Pinion (22) on the splined end of the Rotor and retain it with the Rotor Pinion Retainer (21).

4. While holding the Rotor in a vertical position, grasp the Rotor Pinion in copper-covered vise jaws.

5. Place a Vane (11) in each vane slot.

NOTE: The direction of rotation of the Motor depends on the relationship of the Cylinder and End Plates. To obtain desired shaft rotation closely follow instructions in paragraphs 6 and 7.

6. Rotate the End Plate until the 17/64" (6.75 mm) through hole (dowel hole) is facing you. Note there is a similar hole extending lengthwise through the Cylinder (8), and at about 40° to one side of the hole is an air port.

7. Hold the Cylinder upright, facing the dowel hole and with the air port to the **right** for **clockwise** shaft rotation, to the **left** for **counterclockwise** shaft rotation. Then place it over the Rotor so that the dowel hole in the Cylinder and End Plate are in alignment.

8. Slide the other End Plate, crescent grooved side first on the short hub of the Rotor. Rotate it so that the cylinder dowel hole is aligned with the corresponding hole in the Cylinder.

9. Slide the Rear Rotor Bearing (5) on the short hub of the Rotor and against the End Plate. Retain it with the Rear Rotor Bearing Retainer (6).

REPAIR PARTS

To keep costly downtime to a minimum, it is desirable to have on hand certain repair parts. To guide you in the stocking of repair parts, certain Illustration Numbers of the Repair Part List are marked with a bullet (●). We recommend that with parts so indicated, you stock one (pair or set) repair part for every four tools in service.

If the tools are being used in remote geographical areas, or are subject to unusually severe service, the items and quantities should be increased. Contact the nearest Ingersoll-Rand Company Branch for recommendations.