

8492 Power Assembly (Single Rotation) (1900 R.P.M.)

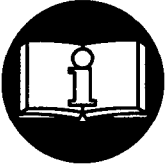

⚠ WARNING

**READ THIS MANUAL CAREFULLY BEFORE INSTALLING,
OPERATING OR SERVICING THIS EQUIPMENT.**

FAILURE TO OBSERVE THE FOLLOWING WARNINGS COULD RESULT IN INJURY.

Pneumatic tools should always be installed and used in accordance with A.N.S.I. B186.1 "Safety Code For Portable Air Tools."

⚠ WARNING

- Operate this tool at 90 p.s.i.g. (6.2 bar) maximum air pressure at the air inlet of the tool.
- Disconnect air supply from tool before performing maintenance procedures.
- Keep hands, clothing and long hair away from rotating end of tool.
- Anticipate and be alert for sudden changes in motion during start up and operation of any power tool.
- Never exceed rated r.p.m. of tool.
- Wear suitable eye and hearing protection while operating tool.
- Do not lubricate tools with flammable or volatile liquids such as kerosene, diesel or jet fuel.
- Do not remove any labels. Replace any damaged label.
- Use only accessories recommended by ARO.

NOTICE

- The use of other than genuine ARO replacement parts may result in safety hazards, decreased tool performance and increased maintenance and may invalidate all warranties.
- ARO is not responsible for customer modification of tools for applications on which ARO was not consulted.
- Tool maintenance and repair should be performed by authorized, trained, competent personnel. Consult your nearest ARO authorized servicer.
- It is the responsibility of the employer to place the information in this manual into the hands of the operator.

For parts and service information, contact your local ARO distributor, or the Customer Service Dept. of the Ingersoll-Rand Distribution Center, White House, TN at PH: (615) 672-0321, FAX: (615) 672-0801.

ARO Tool Products

Ingersoll-Rand Company
1725 U.S. No. 1 North • P.O. Box 8000 • Southern Pines, NC 28388-8000
©1998 INGERSOLL-RAND COMPANY • PRINTED IN U.S.A.

FAILURE TO OBSERVE THE FOLLOWING WARNINGS COULD RESULT IN INJURY.

⚠ WARNING



Wear eye protection when operating or performing maintenance on this tool.

⚠ WARNING



Wear hearing protection when operating this tool.

⚠ WARNING



Turn off air supply and disconnect air supply hose before installing, removing or adjusting any accessory on this tool, or before performing any maintenance on this tool.

⚠ WARNING



Do not use damaged, frayed or deteriorated air hoses and fittings.

⚠ WARNING



Do not overreach when operating this tool. Keep body stance balanced and firm.

⚠ WARNING

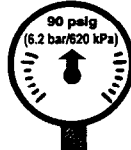

Operate at 90 p.s.i.g. (6.2 bar/620 kPa) maximum air pressure.

WARNING = Hazards or unsafe practices which could result in severe personal injury, death or substantial property damage.

CAUTION = Hazards or unsafe practices which could result in minor personal injury or product or property damage.

NOTICE = Important installation, operation or maintenance information.

ROUTINE LUBRICATION REQUIREMENTS

Lack of or an excessive amount of lubrication will affect the performance and life of this tool. Use only recommended lubricants at below time intervals:

EVERY 8 HOURS OF TOOL OPERATION – Fill lubricator reservoir of recommended F.R.L. with spindle oil (29665). If an in line or air line lubricator is not used, apply several drops of spindle oil (29665) in air inlet.

EVERY 160 HOURS OF TOOL OPERATION – Flush tool with a solution of three (3) parts cleaning solvent to one (1) part spindle oil (or use kerosene).

EVERY 160 HOURS OF TOOL OPERATION – Lubricate gearing. Pack bearings, coat shafts and lubricate gears with NLGI #1 “EP” grease (33153).

AIR SUPPLY REQUIREMENTS

For maximum operating efficiency, the following air supply specifications should be maintained to this air tool:

- AIR PRESSURE – 90 p.s.i.g. (6.2 bar)
- AIR FILTRATION – 50 micron
- LUBRICATED AIR SUPPLY
- HOSE SIZE – 5/16” (8 mm) I.D.

An ARO® model C28231–810 air line FILTER/REGULATOR/LUBRICATOR (F.R.L.) is recommended to maintain the above air supply specifications.

RECOMMENDED LUBRICANTS

After disassembly is complete, all parts, except sealed or shielded bearings, should be washed with solvent. To relubricate parts, or for routine lubrication, use the following recommended lubricants:



<u>Where Used</u>	<u>ARO Part #</u>	<u>Description</u>
Air Motor	29665	1 qt Spindle Oil
“O” Rings & Lip Seals	36460	4 oz. Stringy Lubricant
Gears and Bearings	33153	5 lb. “EP” – NLGI #1 Grease

INSPECTION, MAINTENANCE AND INSTALLATION

Disconnect air supply from the tool or shut off air supply and exhaust (drain) line of compressed air before performing maintenance or service to the tool.

It is important that the tools be serviced and inspected at regular intervals for maintaining safe, trouble-free operation of the tool.

Be sure the tool is receiving adequate lubrication, as failure to lubricate can create hazardous operating conditions resulting from excessive wear.

Be sure that the air supply lines and connectors are of proper size to provide a sufficient quantity of air to the tool.

Tool maintenance and repair shall be performed by authorized, trained, competent personnel. Tools, hose and fittings shall be replaced if unsuitable for safe operation and responsibility should be assigned to be sure that all tools requiring guards or other safety devices shall be kept in legible condition. Maintenance and repair records should be maintained on all tools. Frequency of repair and the nature of the repairs can reveal unsafe application. Scheduled maintenance by competent authorized personnel should detect any mistreatment or abuse of the tool and worn parts. Corrective action should be taken before returning the tool for use.

Disassembly should be done on a clean work bench with a clean cloth spread to prevent the loss of small parts. After disassembly is completed, all parts should be thoroughly washed in a clean solvent, blown dry with air and inspected for wear levels, abuse and contamination. Double sealed or shielded bearings should never be placed in solvent unless a good method of re-lubricating the bearing is available. Open bearings may be washed but should not be allowed to spin while being blown dry.

Upon reassembling, lubricate parts where required. Use 33153 grease, or equivalent, in bearings. Use 36460 lubricant for “O” ring assembly. When assembling “O” rings or parts adjacent “O” rings, care must be exercised to prevent damage to the rubber sealing surfaces. A small amount of grease will usually hold steel balls and other small parts in place while assembling.

When replacement parts are necessary, consult drawing containing the part for identification.

Always use clean, dry air. Dust, corrosive fumes and/or excessive moisture can damage the motor of an air tool. An air line filter can greatly increase the life of an air tool. The filter removes rust, scale, moisture and other debris from the air lines. Low air pressure (less than 90 p.s.i.g.) reduces the speed of the air tool. High air pressure (more than 90 p.s.i.g.) raises performance beyond the rated capacity of the tool and could cause injury. Shown below is a typical piping arrangement.

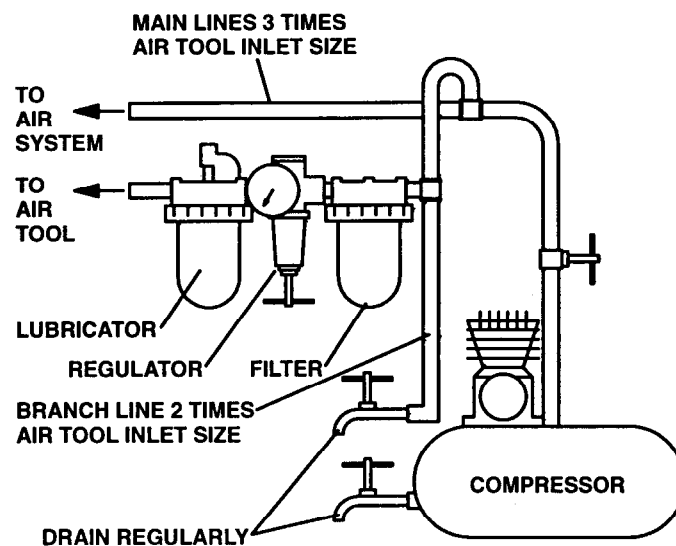

8492
(Single Rotation) (1900 R.P.M.)

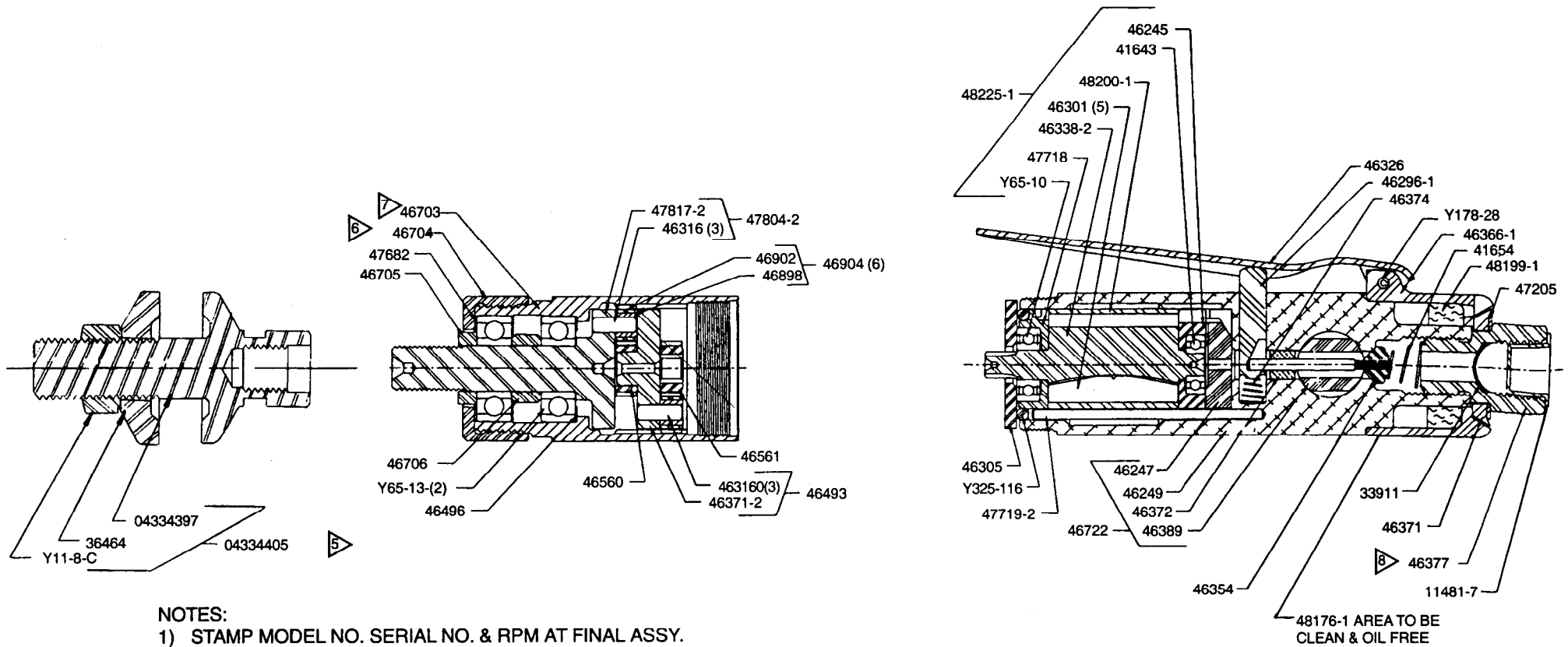

NOTES:

- 1) STAMP MODEL NO. SERIAL NO. & RPM AT FINAL ASSY.
- 2) USE TEST PROCEDURE 32400-8492.
- 3) PLACE LOOSE PARTS IN 24917-3 BAG AND INCLUDE WITH TOOL.

- 5) ASSEMBLE 0433405 TO 47817-2 TO 10-14 LB/FT.
- 6) ASSEMBLE 46704 TO 46703 TO 40-44 LB/FT.
- 7) ASSEMBLE 46703 TO 46249 TO 40-44 LB/FT.
- 8) ASSEMBLE 46377 TO 46249 TO 8-12 LB/FT.

TPM.1030