



Tool Products

OPERATOR'S MANUAL

INCLUDING: OPERATION, INSTALLATION & MAINTENANCE

Released: 6-30-95

Revised:

"0" SERIES POWER UNIT

Model 7789
500 R.P.M.



⚠ WARNING

READ THIS MANUAL CAREFULLY BEFORE INSTALLING, OPERATING OR SERVICING THIS EQUIPMENT.

FAILURE TO OBSERVE THE FOLLOWING WARNINGS COULD RESULT IN INJURY.

Pneumatic tools should always be installed and used in accordance with A.N.S.I. B186.1 "Safety Code For Portable Air Tools."

⚠ WARNING

- Operate this tool at 90 p.s.i.g. (6.2 bar) maximum air pressure at the air inlet of the tool.
- Disconnect air supply from tool before removing/installing bit, socket or device attached to tool or performing maintenance procedures.
- Keep hands, clothing and long hair away from rotating end of tool.
- Anticipate and be alert for sudden changes in motion during start up and operation of any power tool.
- Never exceed rated r.p.m. of tool.
- Wear suitable eye and hearing protection while operating tool.
- Tool shaft can continue to rotate briefly after throttle is released.
- Do not lubricate tools with flammable or volatile liquids such as kerosene, diesel or jet fuel.
- Do not remove any labels. Replace any damaged label.
- Use only accessories recommended by ARO.

⚠ WARNING

Repeated prolonged operator exposure to vibrations which may be generated in the use of certain hand-held tools may produce Raynaud's phenomenon, commonly referred to as Whitefinger disease. The phenomenon produces numbness and burning sensations in the hand and may cause circulation and nerve damage as well as tissue necrosis. Repetitive users of hand-held tools who experience vibrations should closely monitor duration of use and their physical condition.

NOTICE

- The use of other than genuine ARO replacement parts may result in safety hazards, decreased tool performance and increased maintenance and may invalidate all warranties.
- ARO is not responsible for customer modification of tools for applications on which ARO was not consulted.
- Tool maintenance and repair should be performed by authorized, trained, competent personnel. Consult your nearest ARO authorized servicer.
- It is the responsibility of the employer to place the information in this manual into the hands of the operator.

For parts and service information, contact your local ARO distributor, or the Customer Service Dept. of the Ingersoll-Rand Distribution Center, White House, TN at PH: (615) 672-0321, FAX: (615) 672-0801.

ARO Tool Products

Ingersoll-Rand Company
1725 U.S. No. 1 North • P.O. Box 8000 • Southern Pines, NC 28388-8000
©1995 THE ARO CORPORATION • PRINTED IN U.S.A.



Part of worldwide Ingersoll-Rand

FAILURE TO OBSERVE THE FOLLOWING WARNINGS COULD RESULT IN INJURY.

⚠ WARNING



Wear eye protection when operating or performing maintenance on this tool.

⚠ WARNING



Wear hearing protection when operating this tool.

⚠ WARNING



Turn off air supply and disconnect air supply hose before installing, removing or adjusting any accessory on this tool, or before performing any maintenance on this tool.

⚠ WARNING



Air powered tools can vibrate in use. Vibration, repetitive motions or uncomfortable positions may be harmful to your hands and arms. Stop using any tool if discomfort, tingling feeling or pain occurs. Seek medical advice before resuming use.

⚠ WARNING



Do not carry the tool by the hose.

⚠ WARNING



Do not use damaged, frayed or deteriorated air hoses and fittings.

⚠ WARNING



Do not overreach when operating this tool. Keep body stance balanced and firm.

⚠ WARNING

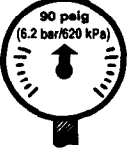

Operate at 90 p.s.i.g. (6.2 bar/620 kPa) maximum air pressure.

NOTICE

<p>⚠ WARNING Read the manual before operating this tool. Operate at 90 psig/6.2 bar max.</p>	<p>This label must appear on the tool at all times. If it is lost or damaged, a replacement label is available at no cost.</p>
---	--

PN 48176-1 LABEL

WARNING = Hazards or unsafe practices which could result in severe personal injury, death or substantial property damage.

CAUTION = Hazards or unsafe practices which could result in minor personal injury or product or property damage.

NOTICE = Important installation, operation or maintenance information.

ROUTINE LUBRICATION REQUIREMENTS

Lack of or an excessive amount of lubrication will affect the performance and life of this tool. Use only recommended lubricants at below time intervals:

EVERY 8 HOURS OF TOOL OPERATION – Fill lubricator reservoir of recommended F.R.L. with spindle oil (29665). If an in line or air line lubricator is not used, apply several drops of spindle oil (29665) in air inlet.

EVERY 160 HOURS OF TOOL OPERATION – Lubricate gearing. Pack bearings, coat shafts and lubricate gears with NLGI #1 "EP" grease (33153). Gearing should contain approximately 1/8 oz. (3.5 g) of grease per reduction.

AIR SUPPLY REQUIREMENTS

For maximum operating efficiency, the following air supply specifications should be maintained to this air tool:

- AIR PRESSURE – 90 p.s.i.g. (6.2 bar)
- AIR FILTRATION – 50 micron
- LUBRICATED AIR SUPPLY
- HOSE SIZE – 5/16" (8 mm) I.D.

An ARO® model C28231–810 air line FILTER/REGULATOR/LUBRICATOR (F.R.L.) is recommended to maintain the above air supply specifications.

RECOMMENDED LUBRICANTS

After disassembly is complete, all parts, except sealed or shielded bearings, should be washed with solvent. To relubricate parts, or for routine lubrication, use the following recommended lubricants:



Where Used	ARO Part #	Description
Air Motor	29665	1 qt Spindle Oil
"O" Rings & Lip Seals	36460	4 oz. Stringy Lubricant
Gears and Bearings	33153	5 lb. "EP" – NLGI #1 Grease

INSPECTION, MAINTENANCE AND INSTALLATION

Disconnect air supply from the tool or shut off air supply and exhaust (drain) line of compressed air before performing maintenance or service to the tool.

It is important that the tools be serviced and inspected at regular intervals for maintaining safe, trouble-free operation of the tool.

Be sure the tool is receiving adequate lubrication, as failure to lubricate can create hazardous operating conditions resulting from excessive wear.

Be sure that the air supply lines and connectors are of proper size to provide a sufficient quantity of air to the tool.

Tool maintenance and repair shall be performed by authorized, trained, competent personnel. Tools, hose and fittings shall be replaced if unsuitable for safe operation and responsibility should be assigned to be sure that all tools requiring guards or other safety devices shall be kept in legible condition. Maintenance and repair records should be maintained on all tools. Frequency of repair and the nature of the repairs can reveal unsafe application. Scheduled maintenance by competent authorized personnel should detect any mistreatment or abuse of the tool and worn parts. Corrective action should be taken before returning the tool for use.

Disassembly should be done on a clean work bench with a clean cloth spread to prevent the loss of small parts. After disassembly is completed, all parts should be thoroughly washed in a clean solvent, blown dry with air and inspected for wear levels, abuse and contamination. Double sealed or shielded bearings should never be placed in solvent unless a good method of re-lubricating the bearing is available. Open bearings may be washed but should not be allowed to spin while being blown dry.

Upon reassembling, lubricate parts where required. Use 33153 grease, or equivalent, in bearings. Use 36460 lubricant for "O" ring assembly. When assembling "O" rings or parts adjacent "O" rings, care must be exercised to prevent damage to the rubber sealing surfaces. A small amount of grease will usually hold steel balls and other small parts in place while assembling.

When replacement parts are necessary, consult drawing containing the part for identification.

Always use clean, dry air. Dust, corrosive fumes and/or excessive moisture can damage the motor of an air tool. An air line filter can greatly increase the life of an air tool. The filter removes rust, scale, moisture and other debris from the air lines. Low air pressure (less than 90 p.s.i.g.) reduces the speed of the air tool. High air pressure (more than 90 p.s.i.g.) raises performance beyond the rated capacity of the tool and could cause injury. Shown below is a typical piping arrangement.

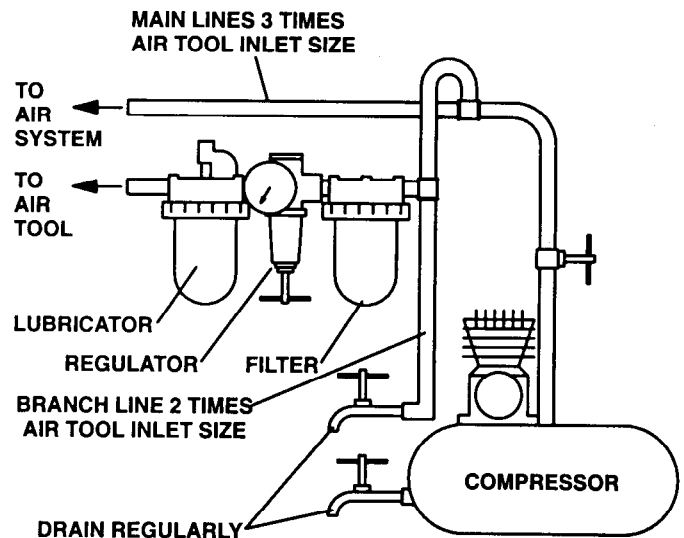

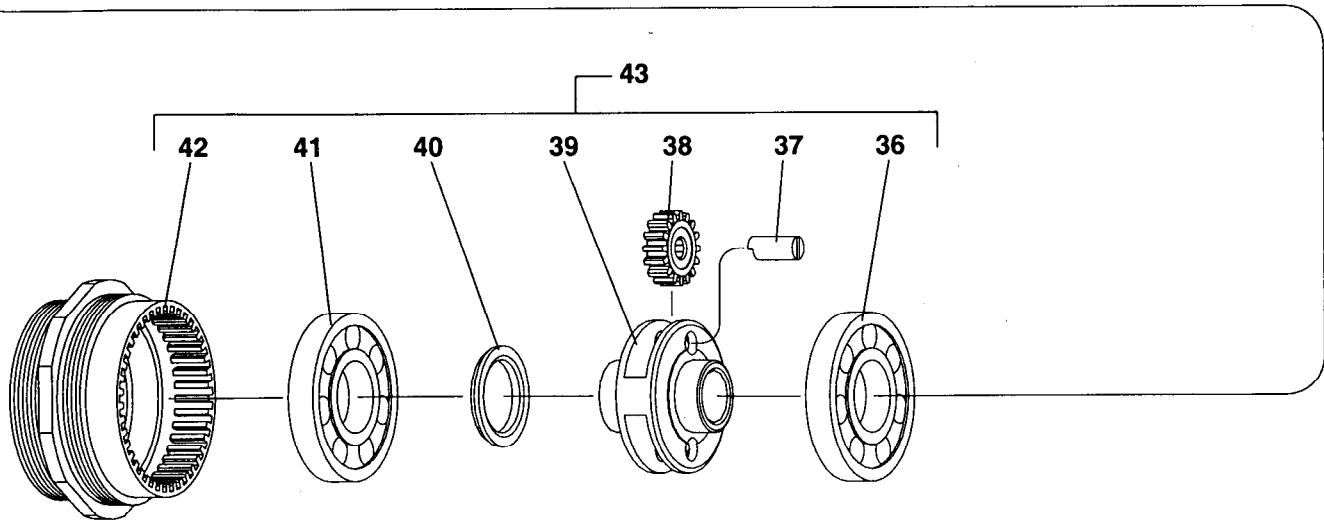
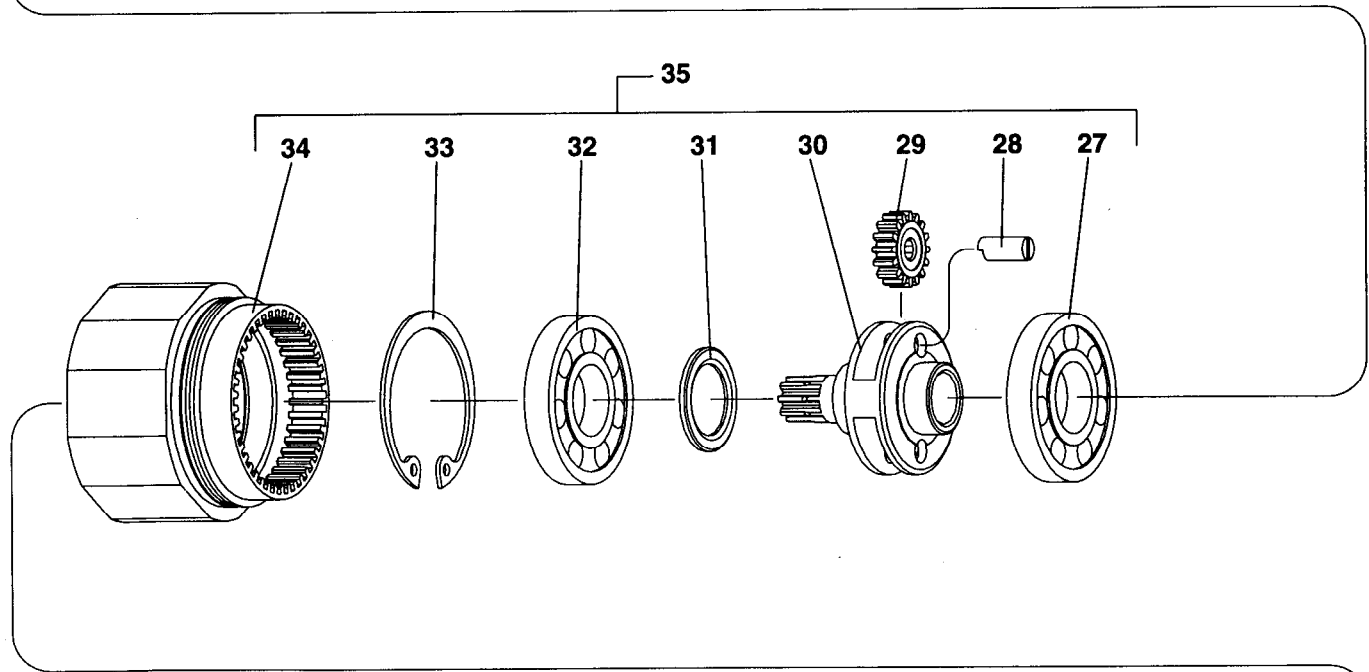
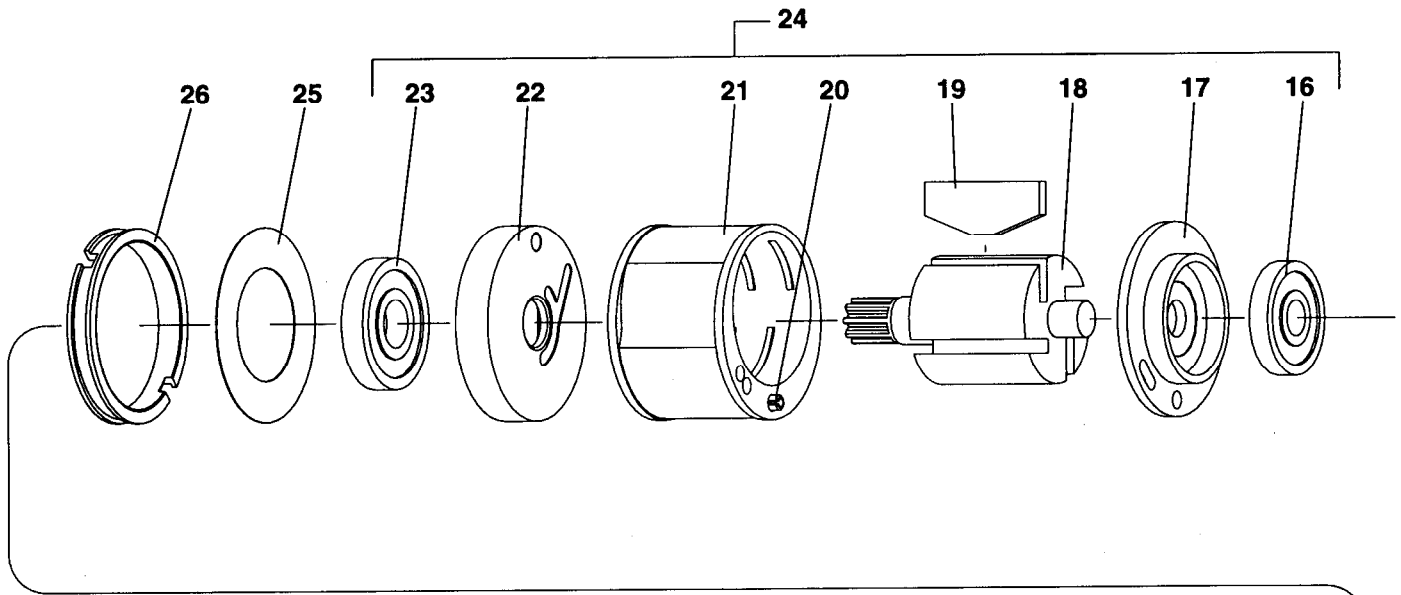

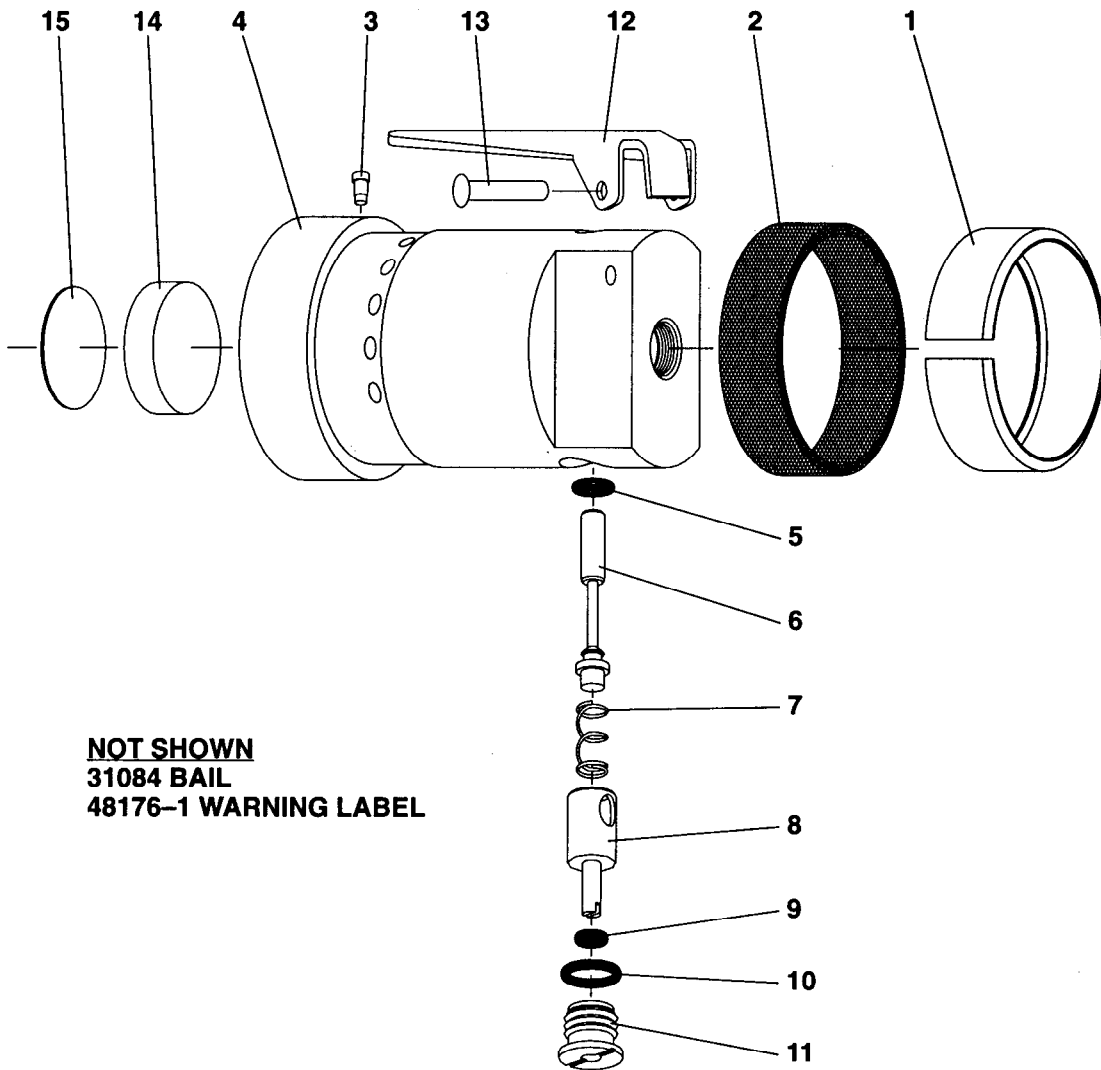

NOT SHOWN
31084 BAIL
48176-1 WARNING LABEL

PART NUMBER FOR ORDERING

PART NUMBER FOR ORDERING

1	Exhaust Deflector	31019	22	Front End Plate	31158
2	Screen	31400	23	Bearing	Y65-15
3	Grease Fitting	35967	24	Motor Assembly	33821
4	Housing Assembly	33442	25	Spacer	32310
5	"O" Ring	Y325-7	26	Spacer	32305
6	Valve Stem	46134	27	Bearing	32325
7	Spring	30609	28	Shaft (2 req'd)	33436
8	Air Regulator	31026	29	Gear (2 req'd) 16 teeth	33440
9	"O" Ring	Y325-8	30	Spindle	33425
10	"O" Ring	Y325-13	31	Spacer	32312
11	Plug	30600	32	Bearing	32325
12	Lever	31023	33	Retaining Ring	Y147-7
13	Rivet	31620	34	Adapter	32326
	Valve and Housing Assembly (includes items 1 thru 13)	33443	35	Auxiliary Gearing Assembly (5.56:1)	33837
14	Cap	38783	36	Bearing	32325
15	Shield	38805	37	Shaft (2 req'd)	33436
16	Bearing	Y65-7	38	Gear (2 req'd) 16 teeth	33440
17	Rear End Plate	30750	39	Spindle	36326
18	Rotor	30745	40	Spacer	33693
19	Blade (4 req'd)	30741	41	Bearing	32325
20	Roll Pin (2 req'd)	Y178-22	42	Ring Gear	36325
21	Cylinder (includes item 20)	32824	43	Drive Gearing Assembly (5.56:1)	36324

DISASSEMBLY/ASSEMBLY INSTRUCTIONS

NOTICE

- Never apply excessive pressure by a holding device which may cause distortion of a part.
- Apply pressure evenly to parts which have a press fit.
- Apply even pressure to the bearing race that will be press fitted to the mating part.
- Use correct tools and fixtures when servicing this tool.
- Don't damage "O" rings when servicing this tool.
- Use only genuine ARO replacement parts for this tool. When ordering, specify part number, description, tool model number and serial number.

DRIVE GEARING DISASSEMBLY

- Using wrenches on flats of ring gear (42) and adapter (34), unthread and remove drive gearing.
- Grasp ring gear in one hand and tap drive end of spindle (39) with a soft face hammer; spindle and components will loosen from ring gear.
- Gearing should not be disassembled further unless damage is evident, as Brinelling of the bearing races may occur, making replacement necessary.
- To disassemble further, remove bearing (41) and spacer (40).
- Remove shafts (37), releasing gears (38).
- To remove bearing (36), insert shafts into spindle and alternately tap ends, loosening bearing.

DRIVE GEARING ASSEMBLY

- Pack bearing (41) with ARO 33153 grease and assemble spacer (40) and bearing (41) to spindle, pressing on inner race of bearing.
- Lubricate gears (38) liberally with ARO 33153 grease and assemble to spindle, securing with shafts (37).
- Pack bearing (36) with ARO 33153 grease and assemble to spindle, pressing on inner race of bearing.
- Assemble gearing into ring gear (42).
- Assemble ring gear and components to tool and tighten, using wrenches on flats of ring gear (42) and adapter (34).

AUXILIARY GEARING DISASSEMBLY

- Remove drive gearing from tool.
- Using wrenches on flats of adapter (34) and housing (4), unthread and remove gearing.
- Grasp adapter (34) in one hand and tap splined end of spindle with a soft face hammer; spindle and components will loosen from adapter.
- Gearing should not be disassembled further unless damage is evident, as Brinelling of the bearing races may occur, making replacement necessary.
- To disassemble further, remove bearing (32) and spacer (31).
- Remove shafts (28), releasing gears (29).
- To remove bearing (27), insert shafts into spindle and alternately tap ends, loosening bearing.

AUXILIARY GEARING ASSEMBLY

- Pack bearing (32) with ARO 33153 grease and assemble spacer (31) and bearing (32) to spindle, pressing on inner race of bearing.

- Lubricate gears (29) liberally with ARO 33153 grease and assemble to spindle, securing with shafts (28).
- Pack bearing (27) with ARO 33153 grease and assemble to spindle, pressing on inner race of bearing.
- Assemble retaining ring (33) and spindle and components into adapter (34).
- Assemble adapter (34) and components to tool and tighten, using wrenches on flats of adapter (34) and housing (4).
- Assemble drive gearing to tool.

MOTOR DISASSEMBLY

- Using wrenches on flats of adapter (34) and housing (4), unthread and remove gearing from tool.
- Remove motor assembly from housing (4).
- Grasp cylinder in one hand and tap splined end of rotor (18) with a soft face hammer; motor will come apart.
- Remove cap (14) and shield (15).
- Remove bearing (16) and end plate (17) from rotor.

MOTOR ASSEMBLY

- Assemble bearing (16) to end plate (17), pressing on outer race of bearing.
- Assemble end plate (17) to rotor, pressing on inner race of bearing.
- Coat four rotor blades (19) with ARO 29665 spindle oil and assemble to rotor slots – straight side out.
- Coat i.d. of cylinder (21) with ARO 29665 spindle and assemble over rotor, aligning roll pin (20) and air inlet holes in end of cylinder with holes in end plate.
- Assemble bearing (23) to end plate (22), pressing on outer race of bearing.
- Assemble end plate (22) to rotor, pressing on inner race of bearing.
- Assemble shield (15) and cap (14) to end plate (17). Be sure rotor turns without binding.
- Assemble motor assembly and spacers (25 and 26) into housing (4).
- Assemble gearing to tool.

HEAD DISASSEMBLY

- Remove plug (11) and "O" ring (10), releasing valve components.
- Remove exhaust deflector (1), releasing screen (2).

HEAD ASSEMBLY

- Assemble screen (2) to housing (4), securing with exhaust deflector (1).
- Lubricate "O" ring (5) and assemble to valve stem (6).
- Lubricate "O" ring (9) and assemble to air regulator (8).
- Assemble valve stem (6), spring (7) and air regulator (8) to housing (4). NOTE: Be sure hole in air regulator is aligned with air inlet of housing.
- Lubricate "O" ring (10) and assemble to plug (11).
- Assemble plug (11) to housing, securing valve components.

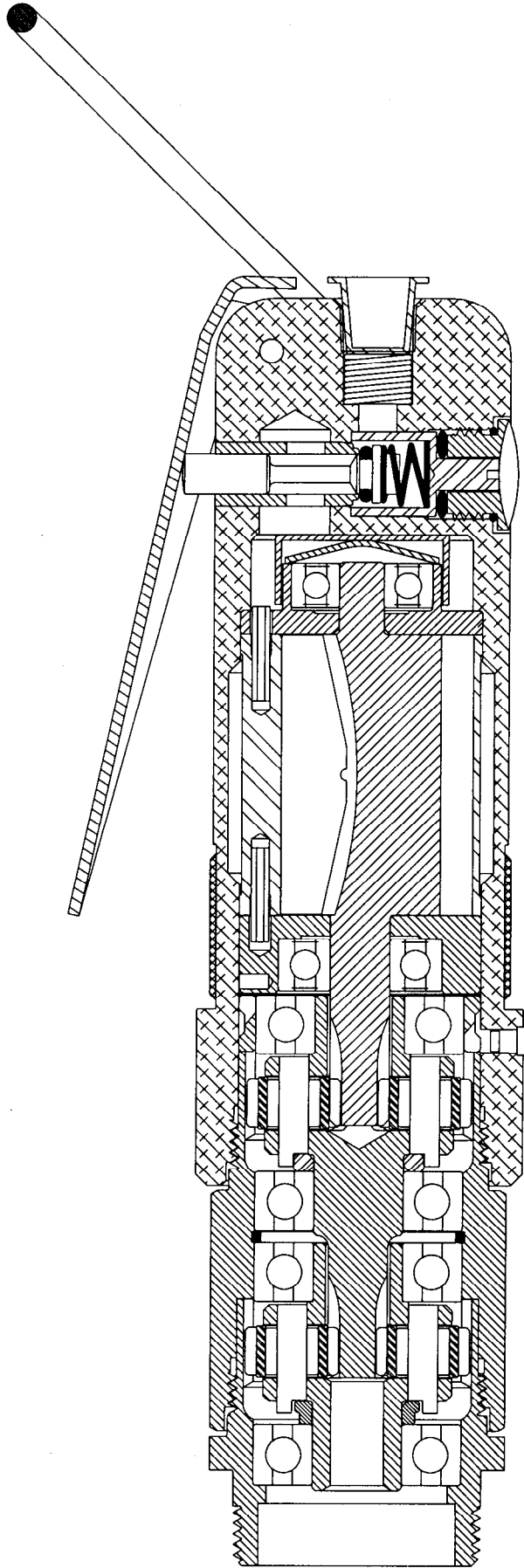



Part of worldwide Ingersoll-Rand

PN 49999-496