



Tool Products

OPERATOR'S MANUAL

INCLUDING: OPERATION, INSTALLATION & MAINTENANCE

Released: 4-1-91

Revised: 10-6-95

Form: 3845-2

50 SERIES POWER UNIT

Models 7772



⚠ WARNING

READ THIS MANUAL CAREFULLY BEFORE INSTALLING, OPERATING OR SERVICING THIS EQUIPMENT.

FAILURE TO OBSERVE THE FOLLOWING WARNINGS COULD RESULT IN INJURY.

Pneumatic tools should always be installed and used in accordance with A.N.S.I. B186.1 "Safety Code For Portable Air Tools."

⚠ WARNING

- Operate this tool at 90 p.s.i.g. (6.2 bar) maximum air pressure at the air inlet of the tool.
- Disconnect air supply from tool before removing/installing bit, socket or device attached to tool or performing maintenance procedures.
- Keep hands, clothing and long hair away from rotating end of tool.
- Anticipate and be alert for sudden changes in motion during start up and operation of any power tool.
- Never exceed rated r.p.m. of tool.
- Wear suitable eye and hearing protection while operating tool.
- Tool shaft can continue to rotate briefly after throttle is released.
- Do not lubricate tools with flammable or volatile liquids such as kerosene, diesel or jet fuel.
- Do not remove any labels. Replace any damaged label.
- Use only accessories recommended by ARO.

⚠ WARNING

Repeated prolonged operator exposure to vibrations which may be generated in the use of certain hand-held tools may produce Raynaud's phenomenon, commonly referred to as Whitefinger disease. The phenomenon produces numbness and burning sensations in the hand and may cause circulation and nerve damage as well as tissue necrosis. Repetitive users of hand-held tools who experience vibrations should closely monitor duration of use and their physical condition.

NOTICE

- The use of other than genuine ARO replacement parts may result in safety hazards, decreased tool performance and increased maintenance and may invalidate all warranties.
- ARO is not responsible for customer modification of tools for applications on which ARO was not consulted.
- Tool maintenance and repair should be performed by authorized, trained, competent personnel. Consult your nearest ARO authorized servicer.
- It is the responsibility of the employer to place the information in this manual into the hands of the operator.

For parts and service information, contact your local ARO distributor, or the Customer Service Dept. of the Ingersoll-Rand Distribution Center, White House, TN at PH: (615) 672-0321, FAX: (615) 672-0801.

ARO Tool Products

Ingersoll-Rand Company
1725 U.S. No. 1 North • P.O. Box 8000 • Southern Pines, NC 28388-8000
©1995 THE ARO CORPORATION • PRINTED IN U.S.A.



Part of worldwide Ingersoll-Rand

FAILURE TO OBSERVE THE FOLLOWING WARNINGS COULD RESULT IN INJURY.

⚠ WARNING



Wear eye protection when operating or performing maintenance on this tool.

⚠ WARNING



Wear hearing protection when operating this tool.

⚠ WARNING



Turn off air supply and disconnect air supply hose before installing, removing or adjusting any accessory on this tool, or before performing any maintenance on this tool.

⚠ WARNING



Air powered tools can vibrate in use. Vibration, repetitive motions or uncomfortable positions may be harmful to your hands and arms. Stop using any tool if discomfort, tingling feeling or pain occurs. Seek medical advice before resuming use.

⚠ WARNING



Do not carry the tool by the hose.

⚠ WARNING



Do not use damaged, frayed or deteriorated air hoses and fittings.

⚠ WARNING



Do not overreach when operating this tool. Keep body stance balanced and firm.

⚠ WARNING

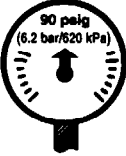

Operate at 90 p.s.i.g. (6.2 bar/620 kPa) maximum air pressure.

NOTICE

<p>⚠ WARNING Read the manual before operating this tool. Operate at 90 psig/6.2 bar max.</p>	<p>This label must appear on the tool at all times. If it is lost or damaged, a replacement label is available at no cost.</p>
---	--

PN 48176-1 LABEL

WARNING = Hazards or unsafe practices which could result in severe personal injury, death or substantial property damage.

CAUTION = Hazards or unsafe practices which could result in minor personal injury or product or property damage.

NOTICE = Important installation, operation or maintenance information.

ROUTINE LUBRICATION REQUIREMENTS

Lack of or an excessive amount of lubrication will affect the performance and life of this tool. Use only recommended lubricants at below time intervals:

EVERY 8 HOURS OF TOOL OPERATION – Fill lubricator reservoir of recommended F.R.L. with spindle oil (29665). If an in line or air line lubricator is not used, apply several drops of spindle oil (29665) in air inlet.

EVERY 160 HOURS OF TOOL OPERATION – Lubricate clutch parts with molybdenum grease (40036-1). Lubricate gearing. Pack bearings, coat shafts and lubricate gears with NLGI #1 "EP" grease (33153). Gearing should contain approximately 1/16 oz. (1.8 g) of grease. Clutch should contain approximately 1/16 oz. (1.8 g) of grease.

AIR SUPPLY REQUIREMENTS

For maximum operating efficiency, the following air supply specifications should be maintained to this air tool:

- AIR PRESSURE – 90 p.s.i.g. (6.2 bar)
- AIR FILTRATION – 50 micron
- LUBRICATED AIR SUPPLY
- HOSE SIZE – 5/16" (8 mm) I.D.

An ARO® model C28231-810 air line FILTER/REGULATOR/LUBRICATOR (F.R.L.) is recommended to maintain the above air supply specifications.

RECOMMENDED LUBRICANTS

After disassembly is complete, all parts, except sealed or shielded bearings, should be washed with solvent. To relubricate parts, or for routine lubrication, use the following recommended lubricants:



Where Used	ARO Part #	Description
Air Motor	29665	1 qt Spindle Oil
"O" Rings & Lip Seals	36460	4 oz. Stringy Lubricant
Gears and Bearings	33153	5 lb. "EP" – NLGI #1 Grease
Clutch	40036-1	1 lb. "EP" Molybdenum Disulfide

INSPECTION, MAINTENANCE AND INSTALLATION

Disconnect air supply from the tool or shut off air supply and exhaust (drain) line of compressed air before performing maintenance or service to the tool.

It is important that the tools be serviced and inspected at regular intervals for maintaining safe, trouble-free operation of the tool.

Be sure the tool is receiving adequate lubrication, as failure to lubricate can create hazardous operating conditions resulting from excessive wear.

Be sure that the air supply lines and connectors are of proper size to provide a sufficient quantity of air to the tool.

Tool maintenance and repair shall be performed by authorized, trained, competent personnel. Tools, hose and fittings shall be replaced if unsuitable for safe operation and responsibility should be assigned to be sure that all tools requiring guards or other safety devices shall be kept in legible condition. Maintenance and repair records should be maintained on all tools. Frequency of repair and the nature of the repairs can reveal unsafe application. Scheduled maintenance by competent authorized personnel should detect any mistreatment or abuse of the tool and worn parts. Corrective action should be taken before returning the tool for use.

Disassembly should be done on a clean work bench with a clean cloth spread to prevent the loss of small parts. After disassembly is completed, all parts should be thoroughly washed in a clean solvent, blown dry with air and inspected for wear levels, abuse and contamination. Double sealed or shielded bearings should never be placed in solvent unless a good method of re-lubricating the bearing is available. Open bearings may be washed but should not be allowed to spin while being blown dry.

Upon reassembling, lubricate parts where required. Use 33153 grease, or equivalent, in bearings. Use 36460 lubricant for "O" ring assembly. When assembling "O" rings or parts adjacent "O" rings, care must be exercised to prevent damage to the rubber sealing surfaces. A small amount of grease will usually hold steel balls and other small parts in place while assembling.

When replacement parts are necessary, consult drawing containing the part for identification.

Always use clean, dry air. Dust, corrosive fumes and/or excessive moisture can damage the motor of an air tool. An air line filter can greatly increase the life of an air tool. The filter removes rust, scale, moisture and other debris from the air lines. Low air pressure (less than 90 p.s.i.g.) reduces the speed of the air tool. High air pressure (more than 90 p.s.i.g.) raises performance beyond the rated capacity of the tool and could cause injury. Shown below is a typical piping arrangement.

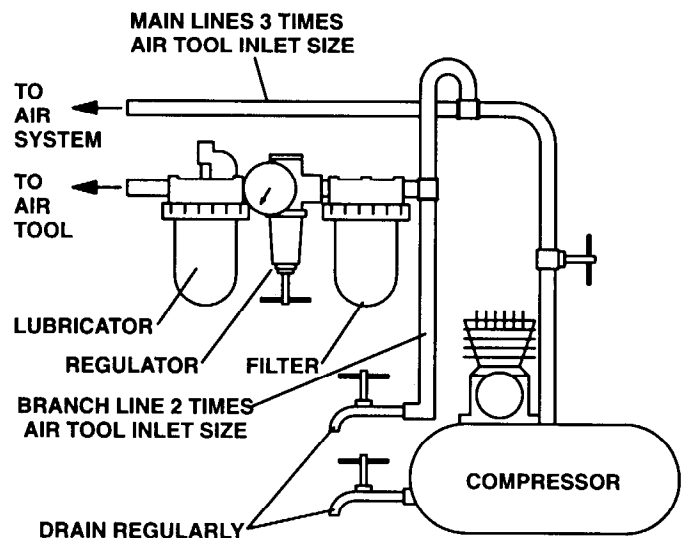

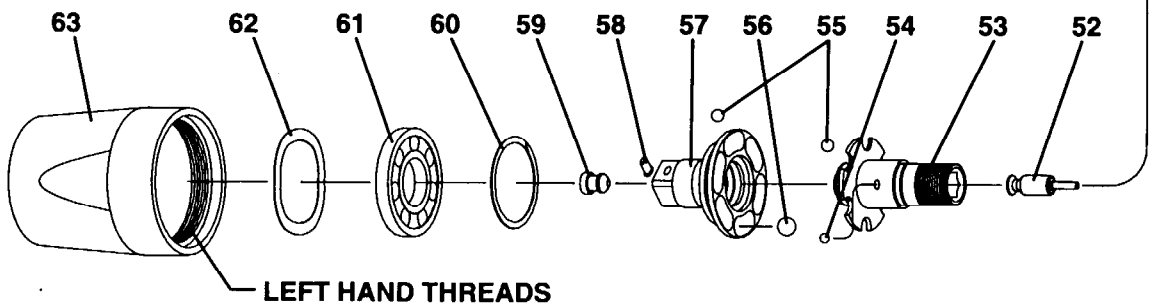
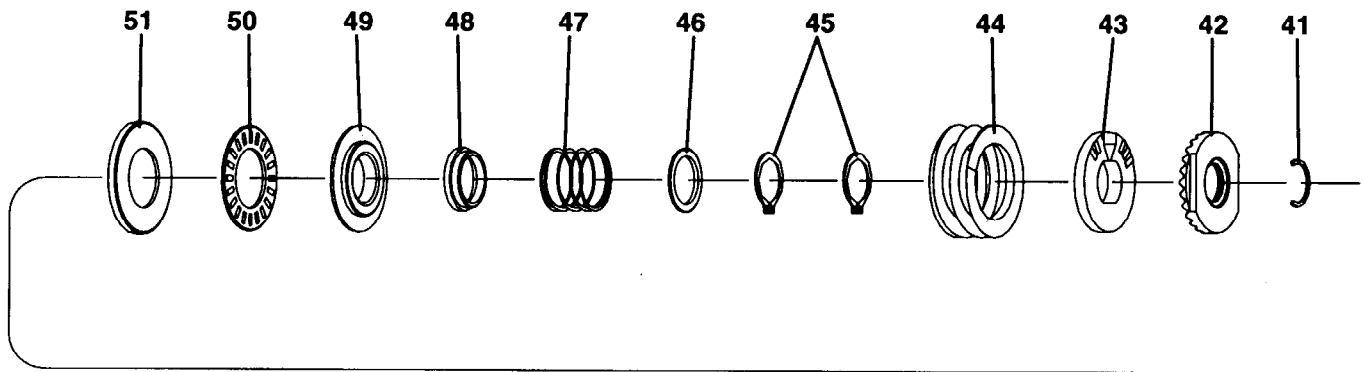

PART NUMBER FOR ORDERING

PART NUMBER FOR ORDERING

1	Retaining Ring	Y147-68	33	Needle Bearing (6 req'd)	42315
2	Screen (2 req'd)	42911	34	Carrier Assembly 6.67:1 ratio	47544
3	Muffler	48944	35	Spindle Assembly 6.67:1 ratio	48968
4	Plug	48812-1	36	Ring Gear	46467
5	Washer	31842	37	Spacer	46496
6	Valve Assembly (includes Y325-6 "O" ring)	48411-1	38	Ball Bearing	Y65-13
7	Spring	47587	39	Washer	47694
8	Housing	48811-1	40	Snap Ring	Y142-2
9	"O" Ring (2 req'd)	Y325-7	41	Snap Ring	Y110-105
10	Valve Assembly (2 req'd)	47880	42	Adjustment Nut	46895
11	Spring (2 req'd)	48806-1	43	Adjustment Washer	48093
12	"O" Ring (2 req'd)	Y325-11	44	Clutch Spring	48047
13	"O" Ring (2 req'd)	Y325-12	45	Retaining Ring (2 req'd)	Y145-18
14	Bushing (2 req'd)	45465	46	Guide	48295-1
15	"O" Ring (2 req'd)	Y325-13	47	Spring	47064
16	Plunger (2 req'd)	47879	48	Ball Sleeve	48294-1
17	Shroud	45468	49	Thrust Race	48094
18	Screw	Y222-156-C	50	Thrust Bearing	38995
19	Trigger	45469	51	Thrust Race	48301-1
20	Roll Pin	Y178-25	52	Plunger	48293-2
	HOUSING ASSEMBLY (includes items 1 thru 20)	48946	53	Spindle	48299-1
21	Throttle Rod	46511-408	54	Ball (6 req'd)	Y16-203
22	Bearing	47724	55	Ball (23 req'd)	Y16-204
23	Rear End Plate	46312-1	56	Ball (6 req'd)	Y16-206
24	Rotor	46469	57	Driven Jaw	48947
25	Blade (5 req'd)	46413	58	Locking Pin	30889
26	Cylinder	46311	59	Rubber Insert	30890
27	Front End Plate	47722	60	Retaining Ring	48300-1
28	Ball Bearing	Y65-13	61	Ball Bearing	Y65-12
	MOTOR ASSEMBLY (includes items 22 thru 28)	47725		AUTO SHUT-OFF CLUTCH ASSEMBLY	
29	"O" Ring	Y325-214		(includes items 41 thru 61)	48948
30	Spacer	46412	62	Wave Washer	47589
31	Locating Pin	47723-1	63	Clutch Housing	48945
32	Planet Gear (6 req'd) 6.67:1 ratio (21 teeth)	46901			

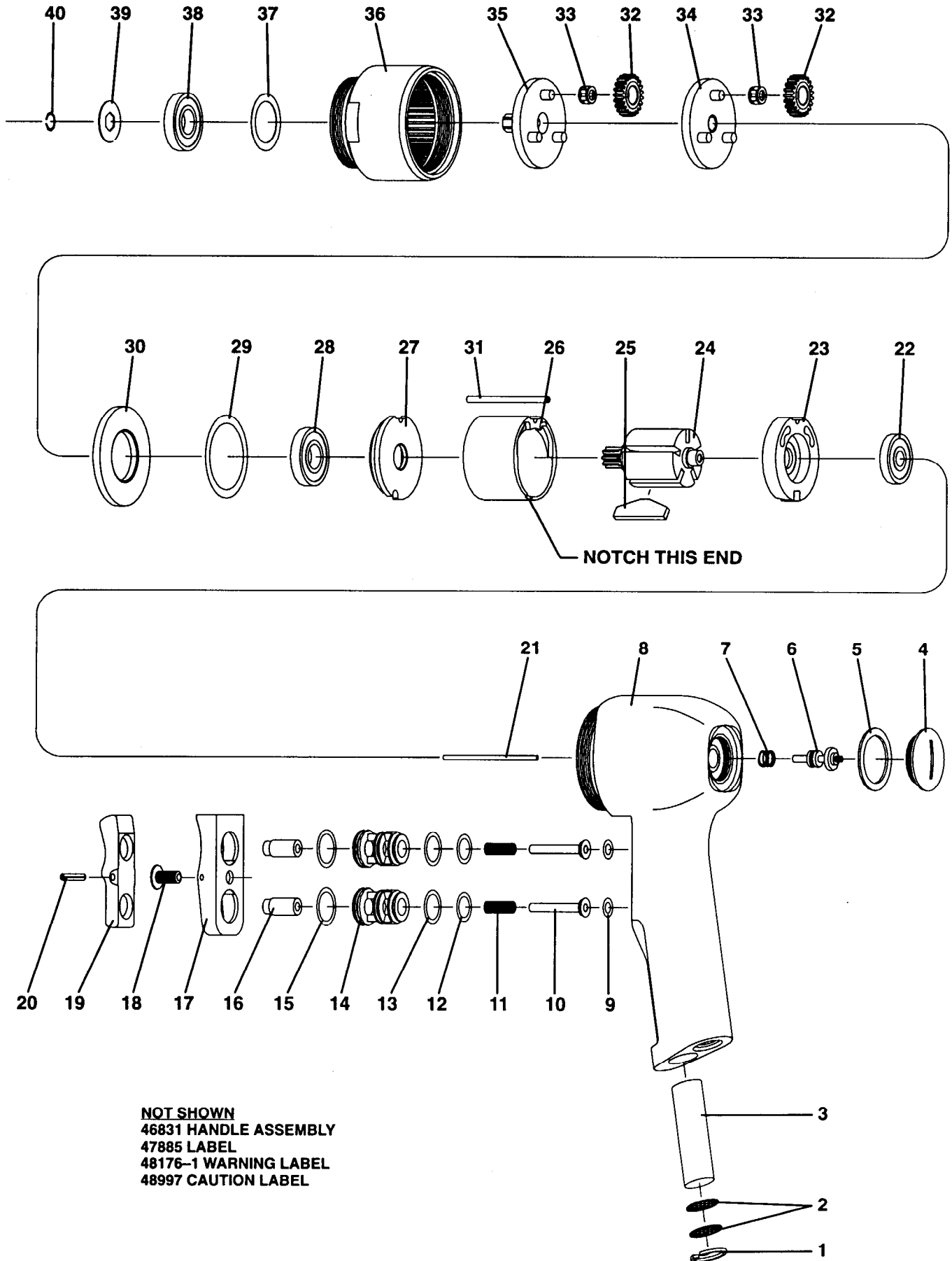

NOT SHOWN
 46831 HANDLE ASSEMBLY
 47885 LABEL
 48176-1 WARNING LABEL
 48997 CAUTION LABEL

DISASSEMBLY/ASSEMBLY INSTRUCTIONS

NOTICE

- Never apply excessive pressure by a holding device which may cause distortion of a part.
- Apply pressure evenly to parts which have a press fit.
- Apply even pressure to the bearing race that will be press fitted to the mating part.
- Use correct tools and fixtures when servicing this tool.
- Don't damage "O" rings when servicing this tool.
- Use only genuine ARO replacement parts for this tool. When ordering, specify part number, description, tool model number and serial number.

CLUTCH DISASSEMBLY

- Clamp handle of tool in a smooth face vise.
- Using wrenches on flats of clutch housing (63) and ring gear (36), unthread and remove clutch housing – LEFT HAND THREADS.
- Remove clutch assembly from tool.
- Clamp driven jaw (57) in a vise, clamping on drive end.
- Remove snap ring (41).
- Remove adjustment nut (42), using a 7/8" wrench.
- Remove adjustment washer (43) and clutch spring (44).
- Remove retaining rings (45).
- Slide off guide (46), spring (47), ball sleeve (48), thrust race (49) and thrust bearing (50). NOTE: Removal of ball sleeve (48) releases six balls (54).
- Remove thrust race (51), releasing six balls (56).
- Remove bearing (61) and retaining ring (60), then rotate driven jaw (57) to remove twelve balls (55). Separate driven jaw (57) and spindle (53), releasing eleven balls (55).

CLUTCH ASSEMBLY

- For clutch part lubrication, use ARO 40036-1 grease on parts as pointed out in this section.
- Lubricate ball grooves of spindle (53).
- Install eleven balls (55) into groove.
- Slide spindle into driven jaw (57), securing balls.
- Assemble twelve balls (55) into driven jaw, securing with retaining ring (60).
- Lubricate bearing (61) with ARO 33153 grease and assemble to driven jaw, pressing on inner race of bearing.
- Lubricate ball pockets of driven jaw and install six balls (56) into pockets, securing with thrust race (51).
- Lubricate and assemble thrust bearing (50) and thrust race (49) to spindle.
- Coat plunger (52) with ARO 29665 spindle oil and assemble to spindle, securing with balls (54). NOTE: Assemble two balls per hole.
- Secure balls with ball sleeve (48).
- Assemble spring (47) and guide (46) to spindle, securing with retaining rings (45).
- Install clutch spring (44).
- Lubricate face of adjustment washer (43) and install on spindle.
- Thread adjustment nut (42) onto spindle, securing with snap ring (41).
- Assemble clutch assembly to tool.
- Assemble wave washer (62) to driven jaw.
- Assemble clutch housing (63) to tool – LEFT HAND THREADS.
- See "Clutch Adjustment".

CLUTCH ADJUSTMENT

CAUTION: DISCONNECT AIR SUPPLY BEFORE ADJUSTING CLUTCH.

- Remove clutch housing, driven jaw and clutch assembly from tool. NOTE: Clutch housing has left hand threads.
- Clamp drive end of driven jaw in a smooth face vise.

- Engage jaws, hold clutch assembly from turning, then rotate adjustment nut (42) using a 7/8" wrench.

GEARING DISASSEMBLY

- Remove clutch from tool (see "Clutch Disassembly").
- Remove ring gear (36), using a wrench on flats.
- Remove snap ring (40) and washer (39).
- Remove spindles and gears from ring gear.
- Do not remove bearing (38) or spacer (37) unless damage is evident.
- To remove bearing (38) and spacer (37) from ring gear, press on spacer (37) from inside splined end of ring gear.

GEARING ASSEMBLY

- Assemble spacer (37) into ring gear.
- Assemble bearing (38) into ring gear, pressing on outer race of bearing.
- Coat shafts of spindle (35) and carrier (34) with ARO 33153 grease.
- Assemble needle bearings (33) and gears (32) to carrier (34) and spindle (35).
- Assemble carrier assembly (34) to spindle assembly (35).
- Assemble gearing into ring gear. Rotate spindle and gears to align gear teeth with splines of ring gear.
- Thread ring gear to tool and tighten, using a wrench on flats.
- Assemble washer (39) and snap ring (40) to spindle.
- Assemble clutch to tool.

MOTOR DISASSEMBLY

- Remove clutch and gearing from tool.
- Remove spacer (30), "O" ring (29) and throttle (21).
- Tap front edge of housing to remove motor assembly. Locating pin (31) should also come out.
- Tap drive end of rotor (24) with a soft face hammer; motor will come apart. NOTE: Bearings are press fit on rotor.
- Remove end plate (23) and bearing (22) from rotor.

MOTOR ASSEMBLY

- Lubricate bearing (22) with ARO 33153 grease and assemble to end plate (23), pressing on outer race of bearing.
- Assemble end plate (23) to rotor, pressing on inner race of bearing.
- Coat five rotor blades (25) with ARO 29665 spindle oil and assemble to rotor slots – straight side out.
- Coat i.d. of cylinder (26) with ARO 29665 spindle oil and assemble over rotor. NOTE: Air inlet slots in end of cylinder must be aligned with two air inlet slots in end plate (23).
- Assemble bearing (28) to end plate (27), pressing on outer race of bearing.
- Assemble end plate (27) to rotor, pressing on inner race of bearing. Be sure rotor turns without binding.
- Insert locating pin (31) into .096" diameter blind hole at bottom of motor cavity in housing.
- Align notches of end plates and cylinder and install motor into housing, aligning notches with locating pin (31).
- Grease and assemble "O" ring (29) to end plate (27).
- Assemble spacer (30) to motor.
- Coat throttle rod (21) with ARO 29665 spindle oil and insert into rotor.
- Assemble gearing and clutch to tool.

HOUSING DISASSEMBLY

- Remove roll pin (20), releasing trigger (19). NOTE: Drive pin out left side of housing.
- Remove screw (18), releasing shroud (17).
- Grasp end of valve (10) and pull to remove valve assembly with bushing (14).

- Remove retaining ring (1) and screens (2) to remove muffler (3).
- Remove plug (4) and washer (5) , releasing valve assembly (6) and spring (7).

HOUSING ASSEMBLY

- NOTE: When a part containing "O" rings has been removed from the tool, it is recommended the "O" rings be replaced upon assembly. Lubricate all "O" rings with ARO 36460 "O" ring lube when assembling.
- Assemble "O" rings (15, 13 and 12) to bushings (14).
- Assemble "O" rings (9) to valves (10).

- Lubricate plungers (16) and valves (10) with ARO 29665 spindle oil.
- Assemble springs (11) to valves (10).
- Assemble plungers (16) and valves (10) to bushings (14).
- Assemble bushings and shroud (17) to tool, securing with screw (18). NOTE: Flats of bushings must be aligned with flats of shroud (17).
- Assemble trigger (19) to tool, securing with roll pin (20).
- Assemble spring (7) and valve assembly (6) to tool, securing with washer (5) and plug (4).
- Assemble muffler (3) and two screens (2) to tool, securing with retaining ring.

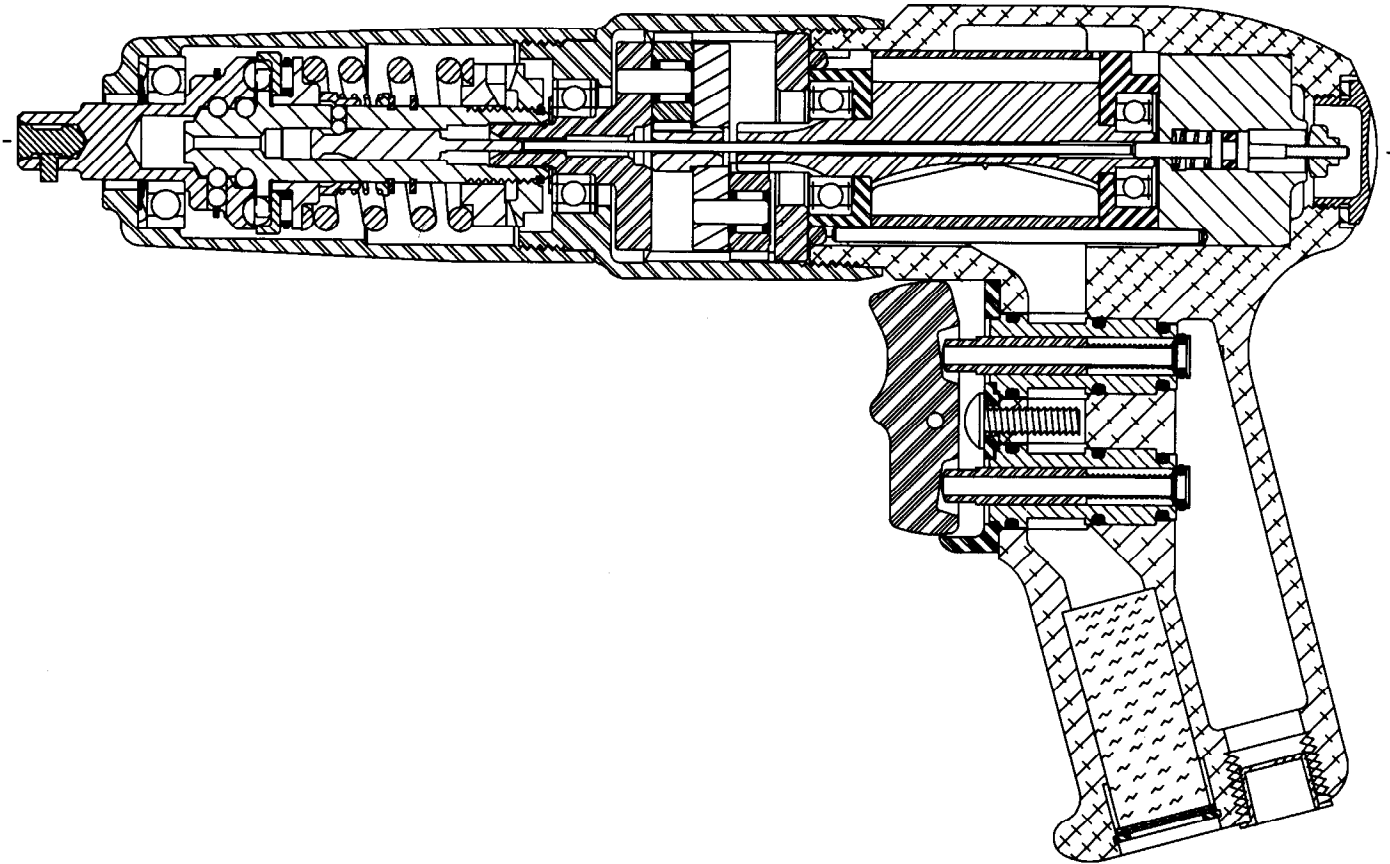



Part of worldwide Ingersoll-Rand

PN 49999-114