

INSTALLATION AND MAINTENANCE MANUAL for SS350 STARTING SYSTEM for TRANSPORTATION APPLICATIONS

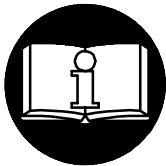

⚠ WARNING

**IMPORTANT SAFETY INFORMATION ENCLOSED.
READ THIS MANUAL BEFORE OPERATING STARTER.**

FAILURE TO OBSERVE THE FOLLOWING WARNINGS COULD RESULT IN INJURY.

- For safety, maximum performance and maximum durability of parts, do not operate SS350 Starters at air pressures over the pressure rating stamped on the nameplate. Use supply lines of adequate size as directed in the installation instructions in this manual.
- Always turn off the air supply and disconnect the air supply hose before installing, removing or adjusting any accessory on this starter, or before performing any maintenance on this starter.
- SS350 Starters are designed for gas operation. They are not totally sealed in dynamic operation since the exhaust must be vented or piped away and there is a possibility of leakage around the output shaft when rotating.
- Caution should be taken when operating these starters on gas because of the danger of fire, explosion or inhalation. After assembling a SS350 Starter always test in accordance with procedures outlined in this manual. Never install a reassembled starter that has not been tested in accordance with the procedures in this manual.
- Do not lubricate starters with flammable or volatile liquids such as kerosene or jet fuel.
- Operate this starter only when properly installed on the engine.
- Do not remove any labels. Replace any damaged label.
- Use accessories recommended by Ingersoll-Rand.

NOTICE

The use of other than genuine Ingersoll-Rand replacement parts may result in safety hazards, decreased starter performance and increased maintenance and will invalidate all warranties.

Ingersoll-Rand is not responsible for customer modification of starters for applications on which Ingersoll-Rand was not consulted.

Repairs should be made only by authorized, trained personnel. Consult your nearest Ingersoll-Rand Authorized Servicenter.

It is the responsibility of the employer to place the information in this manual into the hands of the operator.



Refer All Communications to the Nearest
Ingersoll-Rand Office or Distributor.

© Ingersoll-Rand Company 1999

Printed in U.S.A.

INGERSOLL-RAND
PRODUCTION EQUIPMENT



TABLE OF CONTENTS



	Page
Safety Information	
Warning	3
Specifications	
Model Code Explanation	4
Pinion Data	4
Placing Starter in Service	
Lubrication	5
Installation	5-7
Maintenance Section	
Transportation Piping Diagram	8
Mounting Dimensions	9
Cross Section Drawing	10
Assembly Drawing	11
Parts List	12
Disassembly	13, 14
Assembly	15-18
Lubricator	
Operation	19
Installation	19
Mounting Dimensions	19
Disassembly	20
Assembly	20
Lubricator Testing	21
Parts List	21
Relay Valve	
Lubrication	22
Disassembly	22
Assembly	22
Assembly Drawing and Parts List	23
Selection Guide Information	24



SAFETY INFORMATION



WARNING

FAILURE TO OBSERVE THE FOLLOWING WARNINGS COULD RESULT IN INJURY.

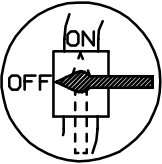
	 WARNING
	Always wear eye protection when performing maintenance on this starter.

	 WARNING
	Always wear hearing protection when testing this starter.

	 WARNING
	Always turn off the air supply and disconnect the air supply hose before installing, removing or adjusting any accessory on this starter, or before performing any maintenance on this starter.

	 WARNING
	Do not use damaged, frayed or deteriorated air hoses and fittings.

SPECIFICATIONS

Model Code Explanation

Example: SS350GB03R31-00E

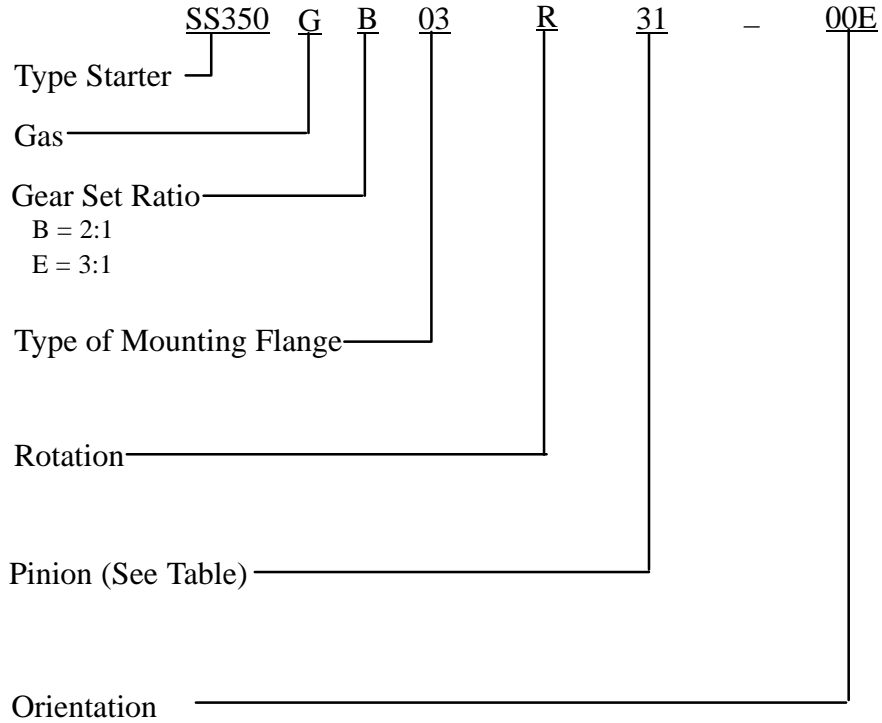

PINION DATA

Part Number	Number of Teeth	Blank	DP / MOD	PD		PA	Rotation	OD	
				inches	mm			inches	mm
ST400-13-77	9	9	3.0	1.063	27.00	15.0	Right	1.369	34.70
ST400-13-85	11	11	8.47	1.299	32.99	15.0	Right	1.600	40.64

*Pinion Code must be specified when ordering.

PLACING STARTER IN SERVICE

The Ingersoll–Rand Starter is a precision piece of equipment intended to give efficient, economical performance over a long period of time. However, as with any product, performance, economy and durability are determined for the most part by a few simple common sense procedures that can be recommended only by the manufacturer and adhered to only by the customer.

The recommendations outlined in this manual are based on 30 years of experience in the air and gas starter field. Study these recommendations and follow them. They can save you considerable time and expense.

LUBRICATION

For temperatures above 32° (0° C), use a good quality SAE 10 non-detergent motor oil.

For temperatures below 32 (0° C), use diesel fuel. Either one of two lubrication system is recommended. For typical Starter installations where the cranking cycle is less than 10 seconds, we recommend the use of an Ingersoll–Rand No. HDL2 Lubricator. Use either diesel fuel or 10W nondetergent motor oil for lubricant. If the cranking cycle is more than 10 seconds, we recommend the Ingersoll–Rand Lubricator No. NL–24–8 installed in the main air supply line. Use a good quality 10W nondetergent oil and adjust the Lubricator to flow 1 to 2 drops per second.

INSTALLATION

General Information

1. Always make certain your starter is properly installed. A little extra time and effort spent in doing a top quality job will contribute considerably toward a reliable starting system that does a superior job of starting your engine quickly under all conditions.
2. We strongly recommend that on all turbine engine installations, and on stationary engines subject to vibration, you use hoses of the specified diameter instead of rigid pipe connections. Turbine engine vibration will soon loosen rigid pipe connections, whereas hoses will absorb the vibration, and connections will remain tight.
3. In the actual mounting of a starter, it is best to have the hose connections already made at the receiver, and to have the starter end of the hose handy for attaching to the starter. Wherever possible, attach the air hoses to the starter before mounting the starter on the engine housing. The reason for following this procedure is twofold:
 - a. After mounting the starter, it is often impossible to make hose connections due to space limitations.
 - b. Once the hoses are attached, they carry some of the weight of the starter and make it easier to complete the mounting.
4. A strainer must be installed in the inlet line for each starter. These 300 mesh strainers provide 50 micron filtration and offer significant protection against supply components. Ingersoll–Rand offers 3 sizes: ST900–267–24 for 1 1/4 inch lines, ST900–267–32 for 2 inch lines and ST900–267–64 for 4 inch lines. Replacement elements are: ST900–266–24 for 1 1/4 inch, ST900–266–32 for 2 inch, and ST900–266–64 for 4 inch lines.
5. When installing the starter, you will usually need a regular ratchet wrench, sockets, socket extension, Allen wrenches, and a torque wrench.
6. The efficiency of a starter can be greatly impaired by an improper hook-up. Hoses smaller than those recommended will reduce the volume of air to the motor, and the use of reducers in the exhaust port will restrict the exhaust and choke the motor. The number of tees and elbows, and the length of the supply line should be kept to a minimum. Use 2" hose or pipe for supply lines up to 15 feet long; use 2–1/2" hose or pipe if the supply line is over 15 feet long.
7. A leak in any of the connections is hazardous.
Make your connections right the first time to avoid unnecessary costs and delays.
On all threaded connections throughout the system, use Loctite® * 56747 Sealant.
Always run your air supply line from the side or top of the receiver—never at or near the bottom. Moisture in the air collects at the bottom of the receiver and could cause corrosion in the starter motor or, worse yet, freeze solid in cold weather so that the starter would be inoperative.
8. Whenever a flammable gas is being used to operate the Starter, all discharges should be piped away to a safe area.
9. Whenever possible, always mount the starter so that the exhaust port is downward. This will help prevent any accumulation of water in the starter motor.

PLACING STARTER IN SERVICE

Orientation of the Starter

If the factory orientation will not fit your engine due to radial location of the Drive Housing or location of the inlet and/or exhaust ports, re-orient the starter as follows:

1. Refer to the dimension illustration and note that the drive housing can be located in any one of eight radial positions relative to the exhaust. The air inlet (motor housing cover) can be located in any one of four radial positions relative to the exhaust port.
2. Study the engine mounting requirements and determine the required orientation of the Drive Housing relative to the Exhaust Port. The Exhaust Port should be pointed downward when installed on the engine. If the Drive Housing has to be reoriented remove the four Drive Housing Cap Screws and rotate the Drive Housing to the required position.

NOTICE

Do not separate the Drive Housing from the Gear Case.

3. Reinstall the Drive Housing Cap Screws and alternately tighten them to a final torque of 20 ft-lb (27 Nm).
4. Now that you have the Drive Housing properly oriented relative to the exhaust port, notice whether or not the Inlet Port will be favorably located for hose installation. If this must be reoriented, remove the four Motor Housing Cover Cap Screws and rotate the Motor Housing Cover to its desired position. Reinstall the Motor Housing Cover Cap Screws and alternately tighten them to a torque of 20 ft-lb (27 Nm).

NOTICE

There are eight holes through the Motor Housing Cover, four of which are not used and are plugged. If the orientation requires that the plugged holes be used to accommodate the Housing Cover Cap Screws, use a flat-end drift to carefully drive the plugs inward. Then reinstall them in the other four holes.

Mounting the Starter

1. Study the Piping Diagram as shown on Drawing TPB715-1 on Page 7. We recommend that the Starter be connected exactly as shown.
2. The air receiver tank for a Starter installation must have a working pressure capability equal to or greater than the maximum pressure at which the Starter will be operated.

WARNING

Bleed off the air pressure through a valve or petcock. Do not remove a plug from the tank while the tank is still pressurized.

3. If you are going to connect to a receiver tank that is already in service, bleed off the air pressure by opening the drain valve. Drain off any water that may have accumulated in the bottom of the tank.

NOTICE

Make certain the connection between the SRV125 or SRV125T Starter Relay and the Receiver Tank is made to the inlet side of the Relay Valve indicated by the word "IN" cast on the valve body.

4. Using a 1-1/4" short nipple, install the SRV125 or SRV125T Starter Relay Valve on the end of the receiver tank as shown in Figure 1.
5. Install the No. SMB-618 Starter Control Valve on the dash panel (for vehicular installations) or some other appropriate panel (for stationary installations).
6. Attach No. TA-STR-100 Starter Instruction Label to the control panel adjacent to the Starter Control Valve.
7. Mount the No. 150BMP-1064 Air Pressure Gauge on or adjacent to the control panel. It should be located where it is readily visible to the operator of the Control Valve.

NOTICE

When connecting the Starter Control Valve to the Relay Valve make certain the hose is connected to the "SUP" side of the Starter Control Valve.

8. Connect the Starter Control Valve to the Relay Valve with 1/4" hose. Install a Tee in this line with a short feeder hose to the Pressure Gauge.
9. Using a piece of heavy duty garden hose, or some other similar large diameter hose, run it from the Relay Valve on the receiver to the Starter location on the engine to determine the exact length of 3/4" hose required.
10. Attach the 3/4" hose to the outlet side of the Relay Valve, and run the hose through the frame, etc. to its final position at the starter location.
11. At this point, determine whether or not it is feasible or practical to attach the hose to the starter before or after the starter is actually mounted. In many cases, it may be necessary to attach the hose to the starter before mounting.

PLACING STARTER IN SERVICE

12. If practical, liberally grease the teeth on the ring gear with a good, sticky gear grease or motorcycle chain lubricant. This will help promote the life of the ring gear and the starter Pinion.
 13. Place the starter into position, and mount it on the flywheel bell housing. Tighten the mounting bolts to 55–60 ft–lb (75–81 Nm) of torque.
 14. Install a 1/4” hose line from the “DEL” side of the starter Control Valve to the “IN” port on the starter Drive Housing.
 15. Install a 1/4” hose line from the “OUT” port on the starter Drive Housing to the small pipe tapped port on top of the starter Relay Valve.
 16. If the exhaust is not to be piped away, install a No. 3BM–WM07 Muffler in the exhaust port on the Motor Housing of the starter.
 17. Pressurize the complete starting system and check every connection with a soap bubble test. There must be no leaks.
- * Registered trademark of Loctite Corporation.

SS350 TRANSPORTATION PIPING DIAGRAM

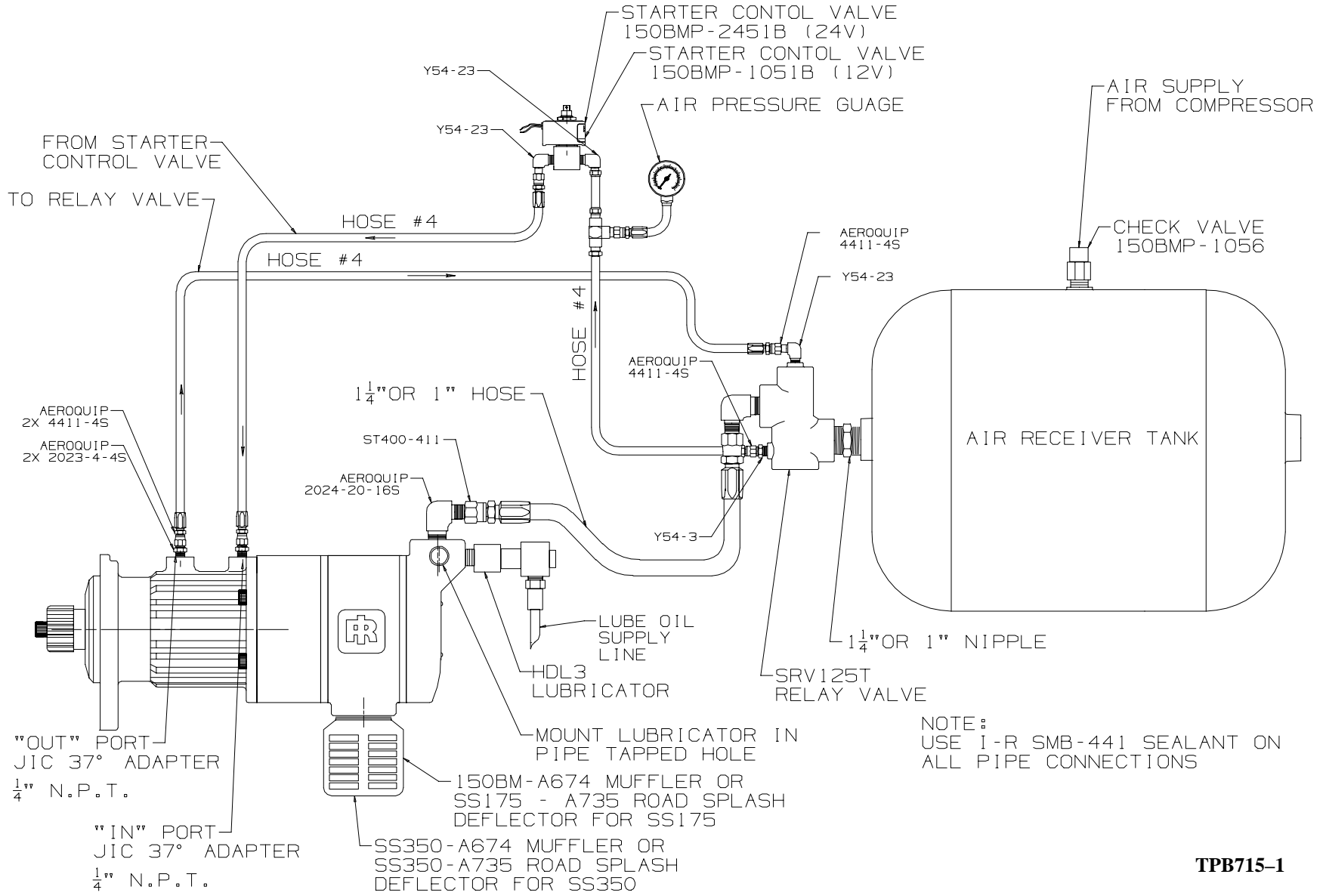

SS350 MOUNTING DIMENSIONS

FOR ORIENTATION PURPOSES PLACE STARTER ON A HORIZONTAL SURFACE & ROTATE INLET VERTICALLY UP, THIS IS POSITION "0" LOCATE EXHAUST "0" THRU "3" ACCORDING TO VIEW BELOW, THEN LOCATE CONTROL PORTS "A" THRU "L" ACCORDING TO APPROPRIATE END VIEW AT RIGHT.

ORIENTATION CODE

0 2 H

POSITION OF INLET (ALWAYS "0")

POSITION OF EXHAUST

POSITION OF CONTROL PORTS

9

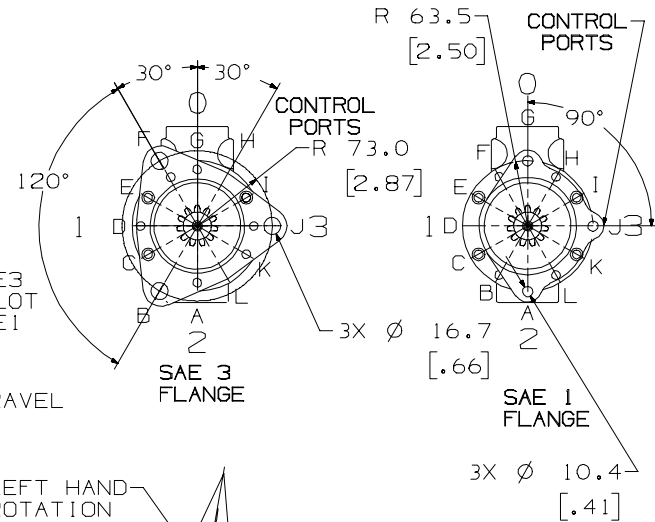
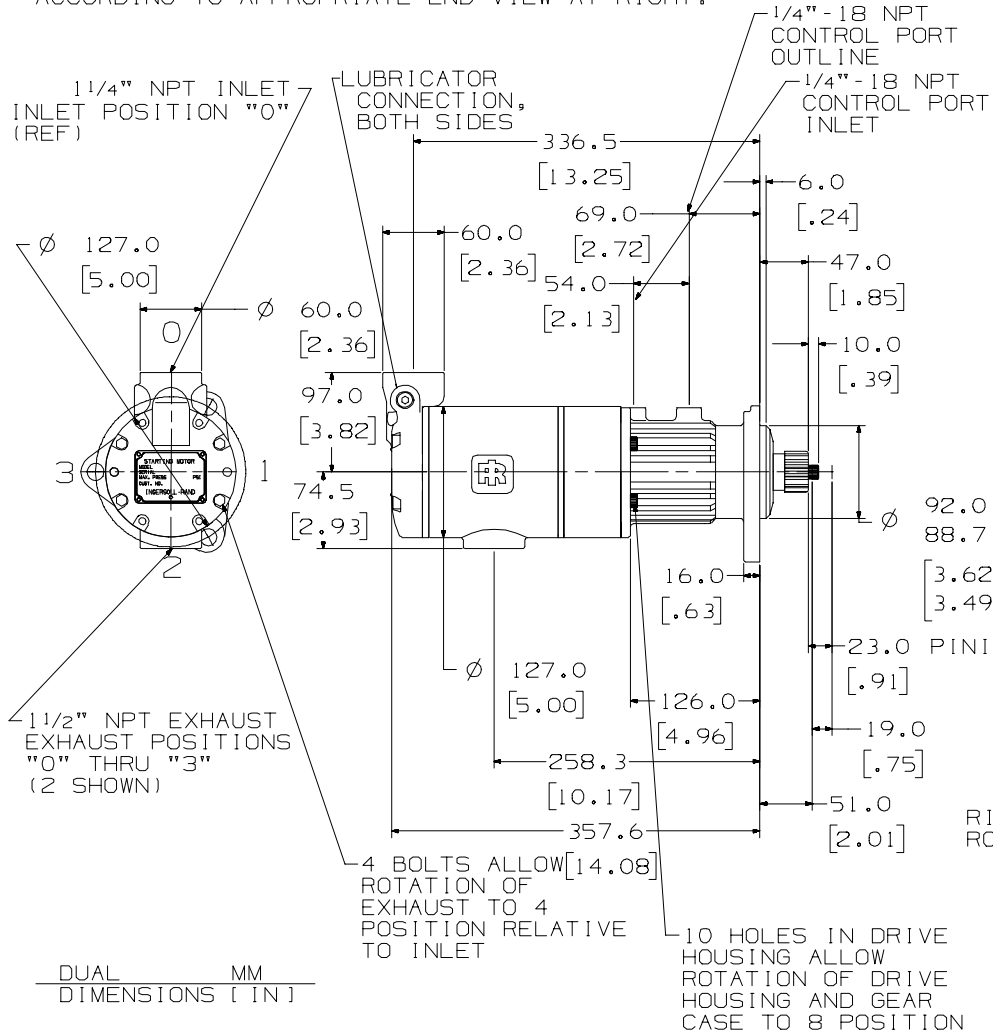

NOTES:

1. THESE MODELS ARE NOT APPROVED FOR APPLICATIONS WHERE THE STARTER IS EXPOSED TO THE TRANSMISSION FLUID.
2. PLEASE READ THE INSTRUCTIONS BEFORE ATTEMPTING TO REORIENT.
3. STARTER WEIGHT = 13Kg (29 lbs)

MAINTENANCE SECTION

SS350 CROSS SECTION DRAWING

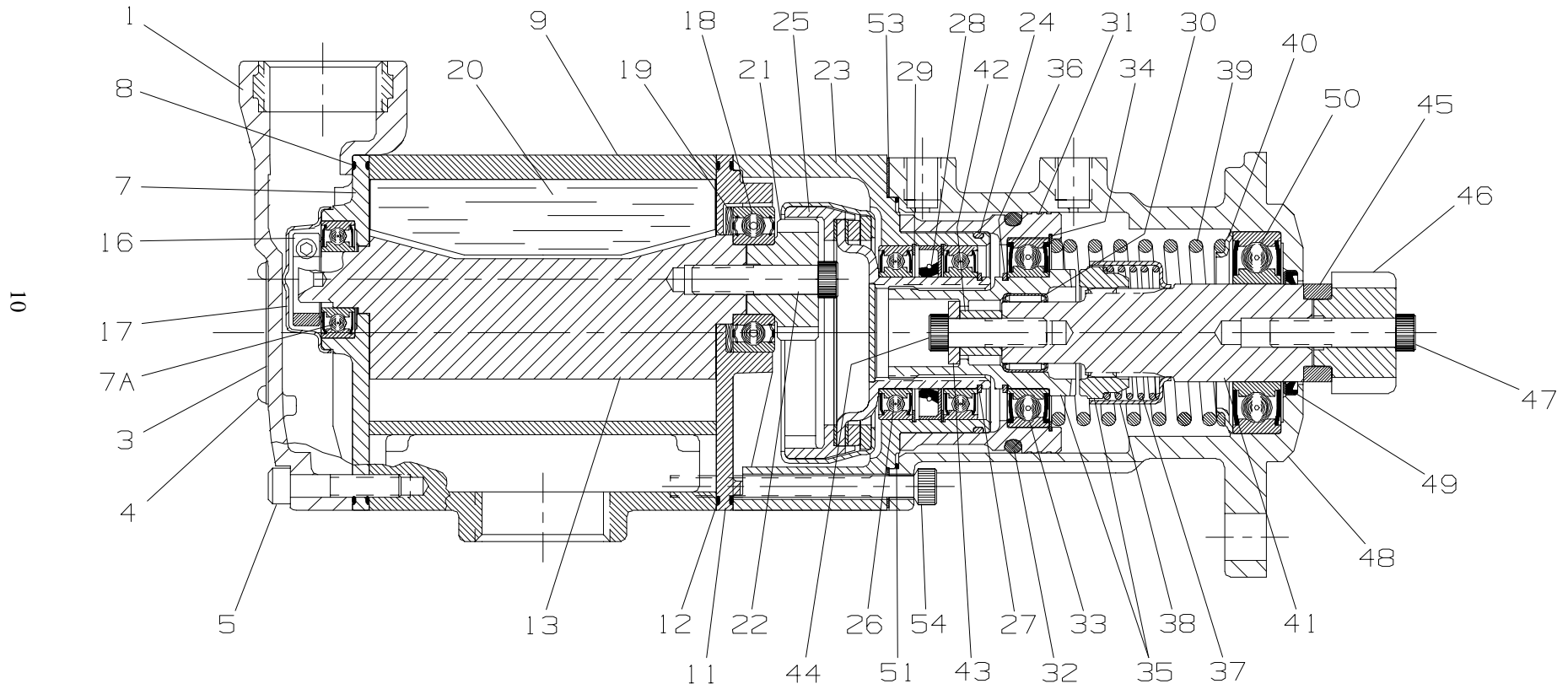

MAINTENANCE SECTION

SS350 PARTS LIST

1	Cover Assembly	SS350-A102	29	Retaining Ring (2)	SS350-270
	Pipe Plug (2)	HSPPS-3	30	Bearing	SS350-278
	Cover	SS350-102	31	Piston	SS350-703
3	Nameplate	SS800-301	32	O-ring	SS350-337
4	Screw (4)	R4K-302	33	Bearing	SS350-339
5	Cap Screw (4)	SS350-25	34	Retaining Ring	SS350-107
6	Bolt Hole Plug (4)	SS350-103	35	Clutch Jaw	
7	Rear End Plate (includes Rear Rotor Bearing)			for RH rotation models	SS350R-586
	for LH rotation models	SS350L-12		for LH rotation models	SS350L-586
	for RH rotation models	SS350R-12	36	Clutch Jaw	
7A	Rear Rotor Bearing	SS350-24		for RH rotation models	SS350R-585
8	O-Ring (4)	SS350-67		for LH rotation models	SS350L-585
9	Cylinder Housing	SS350-3	37	Clutch Spring	
10	Roll Pin (4)	SS350-98		for LH rotation models	SS350L-583
11	Front End Plate	SS350-11		for RH rotation models	SS350R-583
13	Rotor	SS350-53A	38	Sleeve	SS350-367A
16	Clamp	SS350-65	39	Spring	SS350-700
17	Nut Cover	SS350-64	40	Seat	SS350-191
18	Bearing	AM-318	41	Drive Shaft	
19	Washer (2)	SS350-224		for LH rotation models	SS350L-8
20	Vane (set of 5 vanes)	SS350-42		for RH rotation models	SS350R-8
21	Rotor Pinion		42	Spacer	SS350-180
	for "B" ratio Models	SS350B-17	43	Washer	SS350-177
	for "E" ratio Models	SS350E-17	44	Screw	SS350-179
22	Screw		45	Collar	SS350-175
	for "B" ratio Models	SS350-394	46	Drive Pinion	See Table
	for "E" ratio Models	SS350E-732	47	Retaining Screw	SS350-394
23	Gear Case	SS350-37-03	48	Housing	
24	O-ring	SS350-151		for SAE 1 flange mounting	SS350-300-01
25	Gear			for SAE 3 flange mounting	SS350-300-03
	for "B" ratio Models	SS350B-9	49	Seal	SS350-271
	for "E" ratio Models	SS350E-9	50	Bearing	SS350-363
26	Bearing (2)	SS350-359	51	O-ring	SS350-243
27	Retaining Ring (2)	SS350-109	53	Gasket	SS350-245
28	Seal	SS350-272	54	Cap Screw (4)	SS350-744

MAINTENANCE SECTION – SS350 DISASSEMBLY

WARNING

Always wear eye protection when operating or performing any maintenance on this starter. Always turn off the air or gas supply and disconnect the air or gas supply hose before installing, removing or adjusting any accessory on this starter or before performing any maintenance on this starter.

DISASSEMBLY

General Information

1. Always mark adjacent parts on the Motor Housing Cover (1), Cylinder Housing (9), Gear Case (23) and Drive Housing (48) so these members can be located in the same relative position when the Starter is reassembled.
2. Do not disassemble the Starter any further than necessary to replace worn or damaged parts.
3. When grasping a part in a vise, always use leather-covered or copper-covered vise jaws to protect the surface of the part and help prevent distortion. This is particularly true of threaded members.
4. Do not remove any part which is a press fit in or on a subassembly unless the removal of that part is necessary for replacement or repairs.
5. Always have a complete set of seals and O-rings on hand before starting any overhaul of a Series SS350 Starter. Never reuse old seals or O-rings.

Disassembly of the Drive Housing

1. Place the Starter on a workbench in a horizontal position, grasp the Drive Pinion (46) in copper-covered vise jaws.

CAUTION

Do not use excessive clamping force on the Drive Pinion. Grasp it just firmly enough to hold it. Make certain the Starter is firmly supported on the workbench.

2. Remove the Drive Pinion Retaining Screw (47).
3. Loosen the vise and withdraw the Drive Pinion from the Drive Shaft (41).
4. Place the Starter on end with the Drive Shaft upward.
5. Unscrew and remove the four Drive Housing Cap Screws (54).

CAUTION

When unscrewing the Drive Housing Cap Screws, hold the Drive Housing (48) down against the expansion of the Piston Return Spring (39).

6. Remove Drive Housing.

NOTICE

The Gear Case (23) might come off with the Drive Housing. Separate the two if this occurs.

7. Do not remove the Drive Housing Bearing (50) or Drive Housing Seal (49) from the Drive Housing unless it is absolutely necessary and you have a new Drive Housing Bearing and Seal on hand for replacement. These parts are always damaged in the removal process. If it is necessary to remove the Drive Housing Bearing or Seal, place the Drive Housing on the workbench with seal end up. Drive or press the Seal and Bearing from the Drive Housing.

Disassembly of the Piston and Clutch

1. With the Starter standing on end as in Step 4 of the preceding section, lift off the Seat (40) and Spring (39).
2. Grasp the Piston (31) and slide the Piston, Clutch Jaws (35) and Drive Shaft (41) as a unit from the Gear Case (23).
3. Using a small, thin-bladed screwdriver, remove Retaining Ring (34) from the groove inside the Piston.
4. Slide the Piston off the Bearing (33).
5. Remove O-Ring (32) from the Piston.
6. Using a pair of snap ring pliers, remove the Clutch Jaw Retaining Ring (27) from the rear clutch Jaw.
7. Press the Piston Bearing from the rear Clutch Jaw.
8. Grasp the Drive Pinion in copper-covered vise jaws so that the three driving lugs are upward.
9. While engaging the lugs on the Drive Shaft with those on the Drive Pinion, use an 8 mm hexagon wrench to unscrew the Cap Screw (44). Remove the Cap Screw, Washer (43) and Spacer (42).
10. Pull the rear Clutch Jaw from the Drive Shaft.

NOTICE

Do not remove the needle bearing from inside the rear Clutch Jaw unless a new needle bearing is available and ready to install. This bearing will be damaged in the removal process.

11. Slide the front Clutch Jaw, Spring (37) and Sleeve (38) from the Drive Shaft.

Disassembly of the Gear Case

1. Pull the Gear Case (23) along with the Drive Gear (25) and its associated parts, from the motor.
2. Remove O-Ring (24).
3. Using a pair of retaining ring pliers, remove the Bearing Retaining Ring (27).
4. Slide the Drive Gear from the bore of Bearings (26) and Gear Case. It is possible the rear Drive Gear Bearing will remain on the shaft of the Drive Gear.

MAINTENANCE SECTION – SS350 DISASSEMBLY

5. Slide the Drive Gear Bearings from the bore of the Gear Case and/or from the shaft of the Drive Gear.
6. Do not remove Seal (28) from the bore of the Gear Case unless you have a new Seal on hand ready for installation. If it is necessary to remove the Gear Case Seal, use a small thin-bladed screwdriver and remove Retaining Ring (29) from each side of the Gear Case Seal.
7. Press the Gear Case Seal from the Gear Case.

Disassembly of the Motor

1. With the motor in a vertical position, Motor Housing Cover (1) upward, grasp the Cylinder Housing (9) in copper-covered vise jaws.

CAUTION

Do not use excessive clamping force on the Cylinder Housing. Grasp it just firmly enough to support the motor.

2. Using a 6 mm hexagon wrench, remove the four Cap Screws (5) and remove the Motor Housing Cover.
3. Lift the Retaining Nut Cover (17) from the Rear End Plate (7).
4. Using a 3 mm hexagon wrench, loosen the clamping screw in the Retaining Nut (16).
5. Unscrew the Retaining Nut.
6. Lay the motor on its side and grasp the Rotor Pinion in copper-covered vise jaws.
7. Using an 8 mm hexagon wrench, unscrew Retaining Screw (22).
8. Pull the Rotor Pinion from Bearing (18).
9. Thread the Retaining Screw back into the front of the Rotor (13) about five or six turns.
10. Lay the motor on its side and with a soft face hammer, tap the head of the Pinion Retaining Screw to drive the Rotor and Rear End Plate (7) from the opposite end of the Cylinder Housing (9).
11. Support the Rear End Plate on the table of an arbor press and press the Rotor from the Bearing (7A).

WARNING

Bearing (7A) is bonded to the Rear End Plate (7) with Loctite®*. Removal of the Rear Rotor Bearing requires the use of heat. Observe all normal precautions for the handling of hot material.

** Registered trademark of Exxon Corp.

12. Apply enough heat to the periphery of the bearing recess to break the Loctite bond which holds the Bearing to the Rear End Plate.
13. Being careful so as not to get burned, press the Rear Rotor Bearing from the Rear End Plate.
14. Using a wooden handle hammer, or similar piece of wood, reach through the bore of the Cylinder Housing and tap the Front End Plate (11) free from the Roll Pins (10).
15. Slide Rotor Bearing (18) and Wave Washers (19) from the Front End Plate.

Cleaning the Parts

1. Wipe all dirt, grease, etc. from the sealed bearings. Do not wash these parts in kerosene or other solvent, as this will dilute and contaminate any sealed-in lifetime lubricant.
2. Wash all parts except the sealed bearings in clean kerosene or other solvent. Dry the parts with compressed air.

Inspection of Parts

1. Discard all O-Rings and Gaskets. These should not be reused.
2. Check all grease seals and replace any which are worn or distorted.

NOTICE

Discard any grease seal that was removed during disassembly of the Starter.

3. Check the needle bearing in the rear Clutch Jaw. If the bearing is worn, distorted or has loose needles, replace the two-piece Clutch Jaw.

NOTICE

The clutch jaws are a matched set and must be replaced with a matched set.

4. Check all ball bearings. These should run freely without any rough spots or binding. Discard any bearing that gives any indication of wear.
5. Check the Vanes for separation, chipping or other wear. Make sure they fit freely in the vane slots in the Rotor. We recommend that a complete new set of Vanes be installed whenever the Starter is disassembled.

MAINTENANCE SECTION – SS350 ASSEMBLY

ASSEMBLY

General Instructions

1. Always press on the **inner** ring of a ball-type bearing when installing the bearing on a shaft.
2. Always press on the **outer** ring of a ball-type bearing when pressing the bearing into a bearing recess.
3. Whenever grasping a starter or part in a vise, always use leather-covered or copper-covered vise jaws. Take extra care with threaded parts or housings.
4. Except for bearings, always clean every part and wipe every part with a thin film of oil or stated type of grease before installation.
5. Check every bearing for roughness. If an open bearing must be cleaned, wash it thoroughly in a suitable cleaning solution and dry with a clean cloth. **Sealed or shielded bearings should never be cleaned.** Work grease thoroughly into every open bearing before installation.
6. Apply a film of O-ring lubricant to all O-rings before final assembly.
7. Unless otherwise noted, always press on the **stamped end** of a needle bearing when installing the needle bearing in a recess. Use a bearing inserting tool similar to the one shown in Dwg. TPD786.

Needle Bearing Inserting Tool

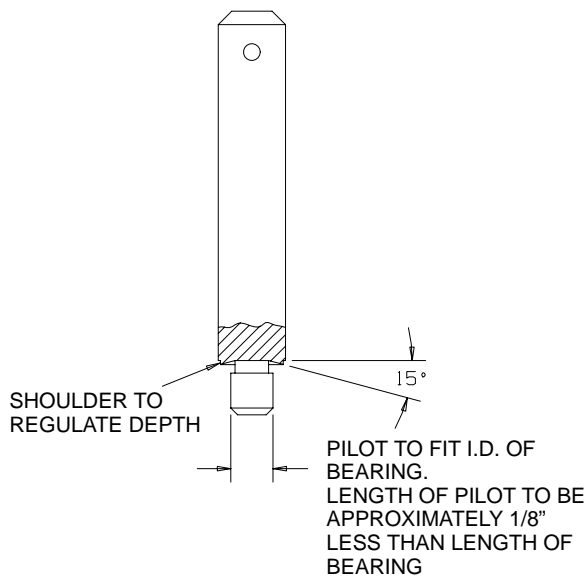

(Dwg. TPD786)

Assembly of the Motor

1. To install the Rear Rotor Bearing (7A) in the Rear End Plate (7), apply a small amount of Loctite RC620®* or equivalent to the outside of the outer race of the Rear Rotor Bearing.
2. Install the Bearing in the recess in the Rear End Plate and allow Loctite to cure for 8–10 hours.

NOTICE

Do not get any Loctite in the bearing, damage to the bearing could result. Do not get any grease on the inside diameter of the Bearing, grease will prevent the Loctite from working.

3. Place Rotor (13) on an arbor press with the three-jaw drive end down.
4. Set Rear End Plate (7), flat side down, on the upper end of the Rotor
5. Place two pieces of .004" (0.10 mm) thick shim stock in opposite positions on the end of the rotor under the end plate.
6. Using a hollow arbor that seals against the inner race of the bearing, press the Rear End Plate down against the shim stock.
7. Remove the Rear End Plate from the arbor press and grasp the Rotor in copper-covered vise jaws with the threaded hub upward.
8. Start the Rear Rotor Bearing Retaining Nut (16), shoulder side first, on the hub of the Rotor.
9. Adjust the Rear Rotor Bearing Retaining Nut until there is a slight drag on the shim stock. Remove the shim stock. Using a 3 mm hexagon wrench, tighten the clamping screw in the Retaining Nut to 10 in-lb (1.1 Nm) torque.

NOTICE

The clearance between the Rear End Plate and the Rotor can be from .002" (0.05 mm) to .005" (0.13 mm) after tightening the clamping screw.

10. Remove the assembled Rotor and Rear End Plate from the vise and stand them upright on the workbench with the Rotor upward.
11. Take one of the End Plate O-Rings (8) and coat it liberally with O-Ring lubricant. Set the End Plate O-Ring down over the Rotor into the groove in the Rear End Plate. Make certain the entire O-Ring is in the groove and that it has sufficient O-Ring lubricant to hold it in the groove.
12. Check the Roll Pins (10) pressed into each end of the Cylinder Housing (9). If the Dowels are bent or broken, remove them and install new Cylinder Dowels.
13. Set the Cylinder Housing on end on two pieces of wood at least 3/4" (19 mm) thick, so that when the Rotor is installed there is clearance for the driving lugs on the hub to extend beyond the face of the Cylinder Housing.

NOTICE

Check the model number of the Starter to determine the direction of rotation. Model numbers having the letter "R" are right-hand rotation; model numbers having the letter "L" are left-hand rotation.

MAINTENANCE SECTION – SS350 ASSEMBLY

For right-hand rotation Models: Stand the Cylinder Housing on end on the two pieces of wood so that the pipe tapped exhaust port is facing you and that the kidney-shaped air port is on the left side of the Cylinder Housing.

For left-hand rotation Models: Stand the Cylinder Housing on end on the two pieces of wood so that the pipe tapped exhaust port is facing you and that the kidney-shaped air port is on the right side of the Cylinder Housing.

14. Take the assembled Rear End Plate and Rotor and insert the Rotor down through the Cylinder Housing until the Cylinder Dowels are aligned with the dowel holes in the Rear End Plate.
15. Tap the Rear End Plate until it seats against the face of the Cylinder Housing. Make certain the End Plate O-Ring does not come out of the groove in the End Plate.
16. Fit the Nut Cover (17) on the hub of the Rear End Plate.
17. Coat a second End Plate O-Ring (8) with O-Ring lubricant and place it in the groove in the trailing face of the Rear End Plate. Make certain the entire O-Ring is in the groove.
18. Place the Motor Housing Cover (1) on the Rear End Plate, making certain that it is oriented relative to the exhaust port in the Cylinder Housing, exactly the way it was prior to disassembly.
19. Using a 6 mm hexagon wrench, install the four Cap Screws (5) and tighten to 20 ft-lb (27 Nm) of torque.
20. Install the two 3/8" Pipe Plugs (2) in the Motor Housing Cover and securely tighten.
21. Turn the motor end for end until the front hub of the Rotor is upward.
22. Wipe each Vane (20) with a film of light oil and install a Vane in each vane slot in the Rotor. Make certain the tapered edge of each Vane faces the center of the Rotor.
23. Coat an End Plate O-Ring (8) with a liberal amount of O-Ring lubricant and place it in the groove on the flat side of the Front End Plate (11). Make certain the entire O-Ring is in the groove and there is a sufficient amount of lubricant to hold it in place.
24. Place the Front End Plate, flat side first, down over the hub of the Rotor so that the Cylinder Dowels are aligned with the dowel holes in the End Plate.
25. Tap the Front End Plate with a soft face hammer until it seats against the Cylinder Housing. Make certain the End Plate O-Ring does not slip out of the groove in the End Plate.
26. Place the two Wave Washers (19) in the bottom of the bearing recess in the Front End Plate.

27. Install Bearing (18) in the bearing recess in the Front End Plate.
28. Place the Pinion (21), lug side first, in the bore of the Front Rotor Bearing so that it engages the lugs on the end of the rotor shaft.

NOTICE

Check to make sure the lugs are engaged.

29. Using an 8 mm hexagon wrench, install Retaining Screw (22) and tighten to 55 ft-lb (74 Nm) of torque.

Assembly of the Gear Case

1. Place Gear Case (23) on workbench with large open end up.
2. Install Retaining Ring (29) in the first upper groove in the small bore of the Gear Case.
3. Place the Gear Case on an arbor press, large end down. Press the Gear Case Seal (28), lip side first, into the small bore of the Gear Case until it seats against the Retaining Ring.
4. Install the second Gear Case Seal Retaining in the second groove in the small bore of the Gear Case.
5. Slide Bearing (26) on the hub of the Drive Gear (25) until it seats.
6. Wipe a thin film of O-Ring lubricant on the lip of the Gear Case Seal and on the shaft of the Drive Gear.
7. Insert the shaft of the Drive Gear into the large open end of the Gear Case and through the Gear Case Grease Seal. Make certain that the lip of the Grease Seal does not turn inside out or that the garter spring does not come off. Push the Drive Gear into the Gear Case until the Drive Gear Bearing seats against the Gear Case Retaining Ring.
8. Slide the second Drive Gear Bearing into the small end of the Gear Case until it seats against the second Gear Case Seal Retaining Ring.
9. Using a pair of retaining ring pliers, install Retaining Ring (27) in the groove on the hub of the Drive Gear.
10. Coat O-Ring (24) with O-Ring lubricant and install it in the groove on the hub of the Gear Case.

Assembly of the Piston and Drive Shaft

1. Grasp the Drive Pinion (46) in copper-covered vise jaws with the lugs on the Drive Pinion pointing upwards.

CAUTION

- Do not use excessive clamping force on the Drive Pinion. Grasp it just firmly enough to hold it.**
2. Stand the Drive Shaft (41) on end to allow the lugs on the large end of the Drive Shaft engage the lugs on the Drive Pinion. Install the Retaining Screw (47) and hand tighten.

MAINTENANCE SECTION – SS350 ASSEMBLY

3. Lubricate the spline on the Drive Shaft with Ingersoll–Rand Grease No. 28.
4. Slide the Sleeve (38), small end first, over the splined end of the Drive Shaft until it seats against the shoulder on the Drive Shaft.
5. Slide the Clutch Spring (37) over the splined end of the Drive Shaft and into the Clutch Spring Cup.

CAUTION

Make certain you install the correct Clutch Spring. Clutch Springs for Starters having the letter “L” in the Model number are color coded “red”. Clutch Springs for Starters having the letter “R” in the Model number have a natural metallic finish.

6. Use Ingersoll–Rand Grease No. 28 in the splines and teeth of the front Clutch Jaw (35) and slide the front Clutch Jaw, small diameter end first, over the splines on the Drive Shaft and against the Clutch Spring.
7. Slide Bearing (30) over the end of the Drive Shaft.
8. Press the Bearing (33) on the shaft of the rear Clutch Jaw (35) and install the Retaining Ring (27).
9. Use Ingersoll–Rand Grease No. 28 on the Needle Bearing inside the rear Clutch Jaw and on the teeth of the rear Clutch Jaw.
10. Place the rear Clutch Jaw, teeth end first, on the end of the Drive Shaft so that the teeth of both Clutch Jaws are engaged.
11. Make certain the splines on the front Clutch Jaw are engaged with the splines on the Drive Shaft by pushing the rear Clutch Jaw downward against the compression of the Clutch Spring. While holding the assembly in this position, drop the Spacer (42) into the bore of the rear Clutch Jaw, followed by the Washer (43).
12. Using an 8 mm hexagon wrench, install the Cap Screw (44) and tighten to a final torque of 55 ft–lb (74 Nm).
13. Work the rear Clutch Jaw back and forth against the compression of the Clutch Spring to make certain it moves freely and travels 15/32” (12 mm). When the Clutch Jaw is pressed down against the Clutch Spring and released, it must return freely. Remove the Retaining Screw and Pinion.
14. Take the assembled Clutch Jaw and Drive Shaft and insert it, splined end first, into the large diameter bore of the Piston (31) until the Piston Bearing is seated.
15. Install the Retaining Ring (34) in the groove in the Piston.
16. Coat O–Ring (32) with O–Ring lubricant and install in the groove on the Piston.

Assembly of the Drive Housing

1. Stand Housing (48) on an arbor press with the large open bore upward. Press Seal (49), lip side first, into the recess at the bottom of the housing bore.
2. Using a sleeve that contacts the outer race of Bearing (50), press the Bearing into the bearing recess at the bottom of the housing bore until it seats.

Assembly of the Starter

1. Grasp the assembled motor in a large vise so the Rotor Pinion (21) is upward.

CAUTION

Do not use excessive clamping force on the Drive Pinion. Grasp it just firmly enough to hold it.

2. Liberally coat an End Plate O–Ring (8) with O–Ring lubricant and place it in the groove on the face of the Front End Plate (11). Make certain the entire O–Ring is in the Groove.
3. Work approximately 150 cc of Ingersoll–Rand Grease No. 28 into the teeth on the Drive Gear (25) and Rotor Pinion (21).
4. Orient the Gear Case (23), exactly the way it was prior to disassembly of the Starter, and place it on the face of the motor so that the Rotor Pinion meshes with the Drive Gear. Make certain the End Plate O–Ring stays in the groove on the face of the Front End Plate.
5. Place the Gasket (53) on the face of the Gear Case, making certain all holes are properly aligned.
6. Lubricate the internal splines of the Drive Gear and the hub of the Gear Case adjacent to the O–Ring (24) with Ingersoll–Rand Grease No. 28.
7. Place the assembled Clutch Jaw (35), Drive Shaft (41) and Piston (31) over the hub of the Gear Case so that the splines on the Clutch Jaw engage the internal splines of the Drive Gear, and so the piston skirt slides down over the hub of the Gear Case until it seats.
8. Wipe a film of Ingersoll–Rand Grease No. 28 on the exterior of the Drive Shaft, Piston and Spring (39).
9. Place the Piston Return Spring over the end of the Drive Shaft until it seats against the Retaining Ring (34) in the front of the Piston. Place the Seat (40) on the end of the Piston Return Spring so that the small lip on the Seat fits inside the Return Spring.

MAINTENANCE SECTION – SS350 ASSEMBLY

10. Liberally coat O–Ring (51) with O–Ring lubricant and install the O–Ring in the counterbore at the base of the Drive Housing (48).
11. Liberally coat the bore of Housing with Ingersoll–Rand Grease No. 28.
12. Making certain that the Drive Housing O–Ring stays in place, slide the Drive Housing down over the Piston Return Spring and Piston until it seats against the Gear Case and is oriented exactly the way it was prior to disassembly.
13. Using a 6 mm hexagon wrench, install the four Cap Screws (54) in the holes in the flange of the Housing. Tighten the Cap Screws to a final torque of 20 ft–lb (27 Nm).
14. Place the Collar (45) over the lugs on the end of the Drive Shaft. If necessary, tap it into place with a plastic hammer.
15. Place the Pinion (46) on the end of the Drive Shaft so that the lugs on the Pinion engage those on the Shaft.
16. Insert the Retaining Screw (47) through the Drive Pinion and thread it into the Drive Shaft.
17. Place the Starter in a horizontal position so that it is supported on the workbench. Grasp the Drive Pinion in copper–covered vise jaws and using an 8 mm hexagon wrench, tighten the Drive Pinion Retaining Screw to a final torque of 55 ft–lb (74 Nm).

** Registered trademark of Exxon Corp.

Testing the Starter

1. Turn the Drive Pinion (46) by hand in the direction of Starter rotation. The clutch should ratchet smoothly with a slight “clicking action.”

NOTICE

Proper Starter rotation is indicated when facing the Drive Pinion. That is a Starter having the letter “R” in the model number is designated as a right–hand rotation model and the Drive Pinion will rotate clockwise when facing the Drive Pinion.

2. Turn the Drive Pinion in the opposite direction of Starter rotation. The gearing and motor should rotate freely with no binding.
3. Attach an air hose to the “IN” port on the Drive Housing (48) and apply 50 psig (3.4 bar / 345 kPa) air pressure. The Drive Pinion should move outward and air should escape from the “OUT” port.
4. Plug the “OUT” port and apply 150 psig (10.3 bar / 1034 kPa) air pressure to the “IN” port. Check to make certain no air is escaping. Measure the distance from the face of the Drive Pinion farthest from the mounting flange to the machined face of the mounting flange. It should be 2.75” (70.0 mm +/- 1.5 mm). With the air pressure on and the Drive Shaft extended, push the Drive Pinion toward the Drive Housing until the Pinion rotates slightly and comes to a solid stop. While holding the Drive Pinion against the stop, measure again the distance from the face of the Drive Pinion to the machined face of the mounting flange. The difference between the two measurements must be .47” (12.0 mm +/- 0.9 mm). Remove the pressure from the “IN” port and measure again the distance from the face of the Drive Pinion to the machined face of the mounting flange. It should be 1.82” (46.2 mm +/- 1.5 mm).
5. Attach a 3/8” (9 mm) air hose to the inlet of the motor and apply 90 psig (6.2 bar / 620 kPa) air pressure. The Starter motor should run smoothly.
6. Plug the exhaust port and apply 30 psig (2.1 bar / 207 kPa) air pressure to the inlet of the motor. Immerse the Starter for thirty seconds in a nonflammable solvent. If the Starter is properly sealed, no bubbles will appear.

LUBRICATOR

OPERATION

The recommended operating range for these Lubricators is 50 psig (3.5 bar/345 kPa) to 250 psig (17.2 bar/1720 kPa) air pressure. These Lubricators are recommended for use with Ingersoll-Rand No. 50 Oil or diesel fuel.

INSTALLATION

These Lubricators are self-priming and may be installed directly into the air starter housing or may be remotely located. Although these Lubricators are capable of drawing lubricant from a source 4 feet (1.22 m) lower than the point of installation, we recommend installation as close as possible to the oil source with piping arranged so that the Lubricator has a constant supply of oil.

NOTICE

Before initial operation, manually fill the oil supply line.

OIL INLET

The oil inlet is tapped 1/8"-27 NPT. Make certain that the fitting you provide is tightened to 15 to 25 ft-lb (20.3 to 33.9 Nm) torque to assure that the joint and oil supply hose are vacuum tight and free of leaks. Threads

of the fitting should be clean and assembled with sealing compound sparingly and evenly applied to the male threads only.

We recommend using the fuel return line as the source of lubricant. However, oil may be supplied from a separate reservoir or the diesel fuel tank. When the diesel fuel tank is the lubricant source, install an HDL1-37 tank filter in the oil supply line at the fuel tank.

Mounting Dimensions

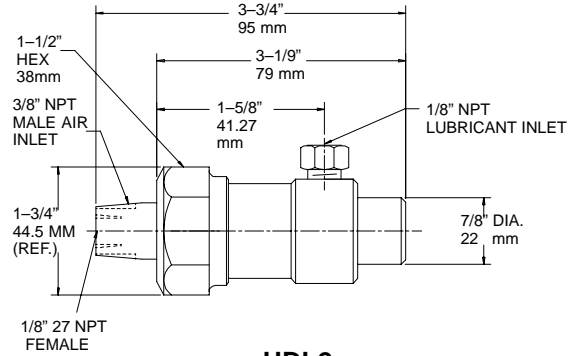

HDL2

(Dwg. TPD995-4)

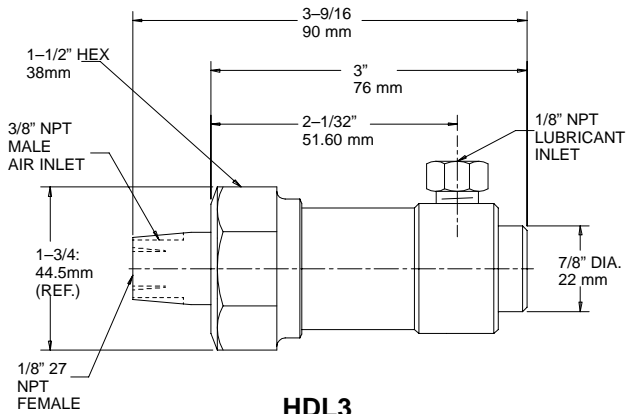

HDL3

(Dwg. TPD1191-1)

LUBRICATOR

DISASSEMBLY

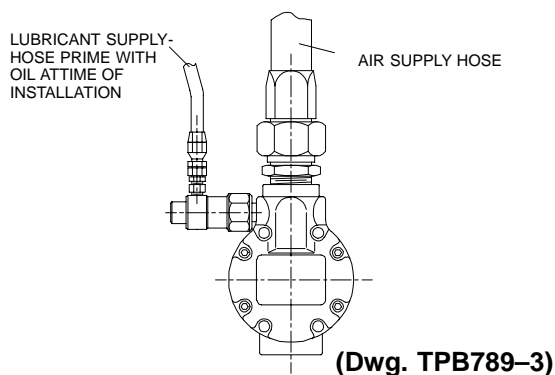

Typical Installation of HDL2 and HDL3 Lubricators

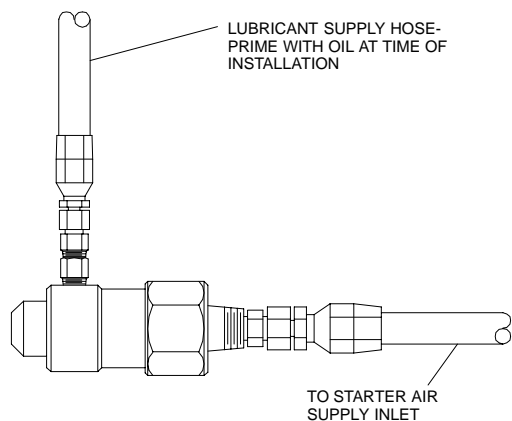

(Dwg. TPC494-3)

Remote Installation of HDL2 and HDL3 Lubricators

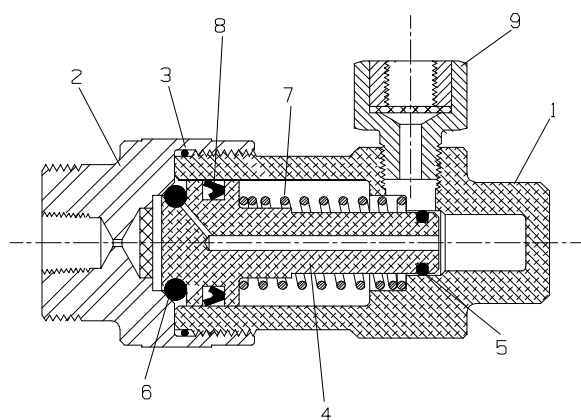

(Dwg. TPD999-2)

General Instructions

1. Whenever grasping the Lubricator in a vise, always wrap the Lubricator in non-marring material or use leather-covered or copper-covered vise jaws to protect the surface of the Lubricator and help prevent distortion.
2. We recommend that you install a new set of O-rings whenever a Lubricator is disassembled.

Disassembly of the Lubricator

1. Carefully grasp the large end of the Housing (1) in vise jaws, inlet end facing upward.
2. Using an appropriate wrench on the knurled section of the Air Inlet (2), unscrew and remove the Air Inlet from the Housing.
3. Lift out the Piston (4) and the Piston Spring (7) from the Housing.
4. Remove the Inlet O-ring (3) from the inside of the Air Inlet.
5. Remove the Rear Piston O-ring (6), Piston Seal (8) and Front Piston O-ring (5) from the Piston.
6. Remove the Filter (9) from the Housing.

ASSEMBLY

General Instructions

1. Always clean every part and wipe every part with a thin film of Ingersoll-Rand No. 50 Oil.
2. Apply a film of o-ring lubricant into all O-rings and the Seal before final assembly.

Assembly of the Lubricator

NOTICE

Install the Piston Seal (8), lip end trailing, into the piston seal groove on the Piston (4). See Dwg TPD999-2

1. Install the Front Piston O-ring (5) into the groove at the small diameter end of the Piston.
2. Install the Rear Piston O-ring (6) into the groove at the large diameter end of the Piston.
3. Install the Inlet O-ring (3) into the internal groove of the Air Inlet (2).
4. Slide the Piston Spring (7) over the small diameter end of the Piston until it butts against the shoulder of the Piston.
5. Grasp the Housing (1) in leather-covered vise jaws, threaded end facing upward.
6. Install the Piston, spring end first, into the Housing.
7. Screw the Air Inlet (2) onto the Housing and tighten the Inlet to 40 ft-lb (54.2 N m) torque.
8. Install Filter (9) in Housing and tighten to 10 to 15 ft-lb (13.6 - 20.3 Nm) torque.

TESTING THE LUBRICATOR

1. Install a clear, unpressurized lubricant supply line to the lubricant supply side of the Lubricator. Submerge the end of the line into a reservoir of Ingersoll-Rand No. 50 Oil or diesel fuel.
2. Apply 50 to 250 psi of air to the air inlet to activate the Piston. Continually apply and discharge air to the air inlet to allow piston action. Each time the Piston is activated, the oil in the lubricant line should move away from the Lubricator. When the inlet air pressure is released, the lubricant should travel back toward the Lubricator with progression after each cycle. The amount of progression will vary depending on lubricant viscosity, fuel line size and temperature. Typically, Ingersoll-Rand No.50 Oil with 1/4" lubricant supply line will pump approximately 1" per cycle at 70 in the HDL2 and 1/2" per cycle at 70 in the HDL3.
3. Apply 50 to 250 psi of air to the lubricant supply side of the Lubricator. Submerge the Lubricator into an oil bath for leak detection. Upon initial testing, some air bubbles may appear due to the Piston's displacing a volume of air through the Air Inlet. After a few seconds, no air leaks should appear from the Lubricator.
4. Apply the air supply to the air inlet side of the Lubricator and repeat step 3.
5. An air leak could be caused by damaged O-rings or Seals from wear or improper installation. Should a leak occur, the Lubricator must be disassembled and repaired or replaced.

PART NUMBER FOR ORDERING



		MODEL HDL2	MODEL HDL3
1	Housing	HDL2-20	HDL3-20
2	Air Inlet	HDL3-21	HDL3-21
◆ 3	Inlet O-ring	HDL2-37	HDL2-37
4	Piston	HDL2-22	HDL3-22
◆ 5	Front Piston O-ring	HDL2-25	HDL3-25
◆ 6	Rear Piston O-ring	HDL2-24	HDL2-24
◆ 7	Piston Spring	HDL1-23	HDL1-23
◆ 8	Piston Seal	HDL1-31	HDL1-31
◆ 9	Filter	HDL2-A47	HDL2-A47
*	Tune-up Kit (includes illustrated parts 3, 5, 6, 7, 8 and 9)	HDL2-TK1	HDL3-TK1

- * Not illustrated.
- ◆ Indicates Tune-up Kit part.

RELAY VALVE

WARNING

Always wear eye protection when lubricating or performing maintenance on the Starter Relay Valve. Always bleed off the air pressure before lubricating or performing any maintenance on the Starter Relay Valve.

LUBRICATION

Periodically lubricate the Starter Relay Valve as follows:

1. Bleed off the air pressure.
2. Disconnect the No. 4 Hose from the tank at the control air supply port near the bottom of the valve opposite the air inlet. In some installations, this 1/4" N. P. T. will be plugged.
3. Remove the plug. Squirt about 1 ounce (30 cc) of 10W oil into the valve through the hose or plug opening.
4. Reconnect the hose or reinstall the plug.

NOTICE

No. SRV150-TK3 Tune-up Kit is available for maintaining the Starter Relay Valve. This Tune-up Kit includes all O-rings, Bumper and End Plug Retaining Ring.

Disassembly of the Starter Relay Valve

1. Bleed off the air pressure.
2. Clamp the Relay Valve in a vise with the Retaining Ring (12) up.

3. Carefully remove the Retaining Ring. The End Plug (10) should spring out. If it does not, tap the Valve Housing (1) lightly with a soft hammer until the End Plug springs out.
4. Remove the End Plug, Spring (8), and Piston Assembly (4).
5. Remove and discard all used O-rings and Bumper (5).
6. Clean all other parts in a clean, suitable cleaning solution in a well ventilated area.

Assembly of the Starter Relay Valve

1. Using o-ring lubricant, lubricate and install the new Piston O-ring (6) and the new Upper Piston O-ring (3) on the Piston.

NOTICE

The Upper Piston O-ring is slightly larger in diameter than the End Plug O-ring (9).

2. Turn the Piston over and insert the new Bumper (5).
3. Using o-ring lubricant, lubricate and install the new End Plug Seal O-ring (11) and the new End Plug O-ring (9) on the End Plug (10).
4. Lubricate the lower small bore of the Valve Housing (1) with o-ring lubricant.
5. Insert the Piston Assembly into the Valve Housing. Push on the Piston until the Piston O-ring (6) seats against the beveled face.
6. Install the O-ring Retainer (7) with the large opening over the Piston O-ring.
7. Place the Piston Spring (8) on the Piston.
8. Place the End Plug Assembly on the Piston Spring.
9. Using a press to hold down the End Plug Assembly, install the End Plug Retaining Ring (12).

RELAY VALVE

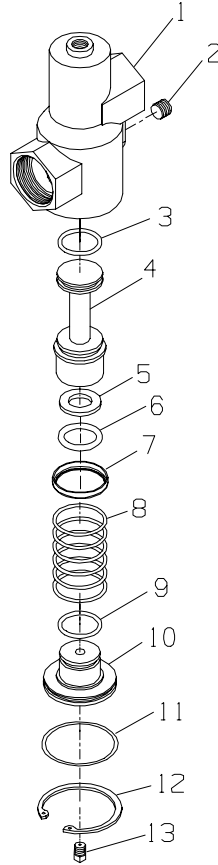

(Dwg. TPD1731)

PART NUMBER FOR ORDERING

PART NUMBER FOR ORDERING

1	Valve Housing for SRV1125T	04333639	10	End Plug for SRV100, SRV125 and SRV150	SRV150-338
	for SRV125	SRV125-40		for SRV150SS	SRV150SS-338
	for SRV150	SRV150-40	◆ 11	End Plug Seal O-ring	Y327-143
	for SRV150SS	SRV150SS-40	◆ 12	Retaining Ring	SRV150-340
2	Pipe Plug	HSPPS-2	13	Pipe Plug (for SRV150SS only) .	SRV150-368
◆ 3	Upper Piston O-ring	SRV150-210	*	Tune-up Kit (includes illustrated parts 3, 5, 6, 7, 9, 11, 12 and non-illustrated Part No. SRV-GR55 Grease)	SRV150-TK3
4	Piston	SRV150-246			
◆ 5	Bumper	SRV150-339			
◆ 6	Piston O-ring	SRV150-211			
◆ 7	O-ring Retainer	SRV150-33			
8	Spring	SRV150-250			
◆ 9	End Plug O-ring	SRV150-67			

◆ Indicates Tune-up Kit part.

Selection Guide Information

MANUFACTURER	ENGINE	CU IN	LITRE	CYLINDERS	TYPE	VANE STARTER	FLANGE	PINION	REMARKS
DAIMLER MERCEDES-BENZ	OM352	346	5.67	6	Diesel	SS350GB03R77	SAE03	R77	
DAIMLER MERCEDES-BENZ	OM352A	346	5.67	6	Diesel	SS350GB03R77	SAE03	R77	
DAIMLER MERCEDES-BENZ	OM355	707	11.58	6	Diesel	SS350GE03R77	SAE03	R77	
DAIMLER MERCEDES-BENZ	OM355H	707	11.58	6	Diesel	SS350GE03R77	SAE03	R77	
DAIMLER MERCEDES-BENZ	OM360	532	8.72	6	Diesel	SS350GE03R77	SAE03	R77	
DAIMLER MERCEDES-BENZ	OM401A	584	9.57	6	Diesel	SS350GE03R77	SAE03	R77	
DAIMLER MERCEDES-BENZ	OM402A	779	12.76	8	Diesel	SS350GE03R77	SAE03	R77	
DAIMLER MERCEDES-BENZ	OM404				Diesel	SS350GE03R77	SAE03	R77	
DAIMLER MERCEDES-BENZ	OM407	696	11.41	6	Diesel	SS350GE03R77	SAE03	R77	
DAIMLER MERCEDES-BENZ	OM424				Diesel	SS350GE03R77	SAE03	R77	
DAIMLER MERCEDES-BENZ	OM429				Diesel	SS350GE03R77	SAE03	R77	
DAIMLER MERCEDES-BENZ	OM441	665	10.90	6	Diesel	SS350GE03R77	SAE03	R77	
DAIMLER MERCEDES-BENZ	OM442	893	14.64	8	Diesel	SS350GE03R77	SAE03	R77	
DAIMLER MERCEDES-BENZ	OM442A	891	14.60	8	Diesel	SS350GE03R77	SAE03	R77	
DAIMLER MERCEDES-BENZ	OM443LA	1116	18.29	10	Diesel	SS350GE03R77	SAE03	R77	
DAIMLER MERCEDES-BENZ	OM444A	1341	21.97	12	Diesel	SS350GE03R77	SAE03	R77	
DAIMLER MERCEDES-BENZ	OM444LA	1341	21.97	12	Diesel	SS350GE03R77	SAE03	R77	
SAAB-SCANIA	D11 SERIES	671	11.00	6	Diesel	SS350GE03R85	SAE03	R85	Use 1/2" Spacer
SAAB-SCANIA	D11 SERIES	671	11.00	6	Diesel	SS350GE03R85	SAE03	R85	Use 1/2" Spacer
SAAB-SCANIA	D14 SERIES	866	14.19	8	Diesel	SS350GE03R85	SAE03	R85	
SAAB-SCANIA	D142 SERIES	866	14.19	8	Diesel	SS350GE03R85	SAE03	R85	
SAAB-SCANIA	D8 / DS8	476	7.80	6	Diesel	SS350GB03R77	SAE01	R77	
SAAB-SCANIA	DS - 11				Diesel	SS350GE03R77	SAE03	R85	
SAAB-SCANIA	DS9	517	8.47	6	Diesel	SS350GB01R77	SAE01	R77	
SAAB-SCANIA	L - 113				Diesel	SS350GE03R77	SAE03	R85	Use 1/2" Spacer

NOTES

United States Office Locations

For Order Entry, Order Status

**Ingersoll-Rand
Distribution Center**
P.O. Box 618
510 Hester Drive
White House, TN 37188
Phone: (615) 672-0321
Fax: (615) 672-0801

For Technical Support

Ingersoll-Rand
1725 U.S. Highway #1-N
Southern Pines, NC 28387
Phone: (910) 692-8700
Fax: (910) 692-7822

Web Site

www.airstarters.com

International Office Locations

Ingersoll-Rand Company

Latin America Operations
Production Equipment Group
730 N.W. 107 Ave., Suite 300
Miami, FL 33172-3107
Phone: (305) 559-0500
Fax: (305) 559-7505

Ingersoll-Rand Japan, Ltd.

Shin-Yokohama Square Bldg.
5th Floor, 2-3-12 Shin Yokohama
Kouhoku-ku, Yokohama-shi
Kanagawa Pref. 222, Japan
Phone: (81) 45 476 7801 / 7817
Fax: (81) 45 476 7806

Ingersoll-Rand Australia, Ltd

1 Hartnett Drive
Seaford VIC 3198 Australia
Mail: Private Mail Bag 2
Carrum Downs Business Centre.
Vic. 3201, Australia
Phone: (03) 9554 1600
Fax: (03) 9554 1607

Ingersoll-Rand Wadco Tools Limited

37A Site IV
Sahibabad Industrial Area
Dist. Ghaziabad 201010 (UP)
India
Phone: (0575) 771001/771002/771003/771004
Fax: (0575) 771005

Compagnie Ingersoll-Rand

5-7, Avenue Albert. Einstein
B.P. 113
78192 Trappes Cedex
France
Phone: 0 (1) 30 50 61 10
Fax: 0 (1) 30 50 02 18

Ingersoll-Rand Canada

Administrative Offices

Distribution Center

51 Worchester Road
Toronto, Ontario
Canada M6W 4K2
Phone: (416) 213-4500
Fax: (416) 213-4616