

# AE-7010

## EXPLODED VIEW

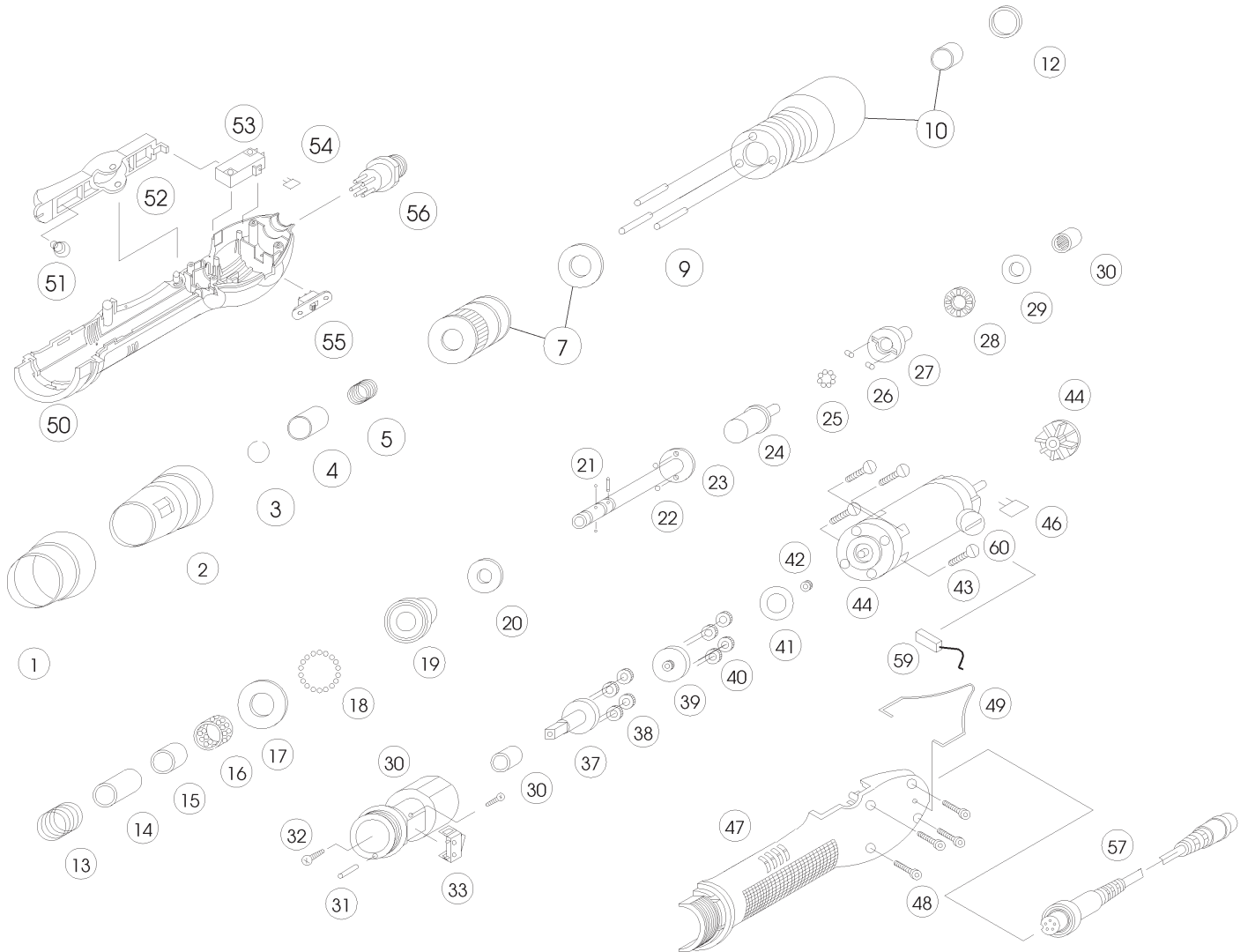

## PARTS LIST — FOR REFERENCE ONLY

Index Number	Part Number	Description	Qty.	Index Number	Part Number	Description	Qty.	Index Number	Part Number	Description	Qty.
1	6R5011	RETAINING RING	1	24	4C2011	SUPPORT BOND	1	48	8K1011	HEXAGONAL HEAD SCREW	4
2	6H1031	INDICATIVE RING	1	25	4B2014	BALL BEARING	9	49	4F1041	HANGAR RING	1
3	4U1051	C-RING	1	26	4B301 2	BALL BEARING	2	50	6Z1065	PLASTIC HOUSING (LEFT)	1
4	4H2042	SLEEVE	1	27	4K1052	TOP CLUTCH	1	51	4S3051	TRIGGER SPRING	1
5	4S3062	SLEEVE SPRING	1	28	4E4021	PLAIN BEARING & WASHER	1	52	6P1021	TRIGGER	1
7	4A4017	TORQUE ADJUSTMENT RING/WASHER ASSY.	1	29	4E4021	PLAIN BEARING & WASHER	1	53	2S1021	OPERATIVE SWITCH	1
9	4N1025	TORQUE ADJUSTMENT PIN	3	30	4A7016	GEAR HOUSING/BEARING SUB ASSEMBLY	1	54	2C4011	CONDENSER (0.1K 100V)	1
10	4A1017	FRONT HOUSING/SLEEVE SUB ASSEMBLY	1	31	4N1021	PIN	1	55	2S2011	FUNCTION SWITCH	1
12	4W4212	WASHER	1	32	8S6524	TAPPING SCREW	2	56	2G1022	5P SOCKET	1
13	4S1093	TORQUE SPRING	1	33	2A7015	MICRO SWITCH SUB ASSEMBLY	1	57	2W2023	5P-5P CONNECTOR WIRE	1
14	4Q1063	SLEEVE	1	34	8S6504	SCREW	1	59	2B1013	BRUSH	2
15	4Q1062	SLEEVE	1	37	4L2051	BOTTOM GEAR HOLDER	1	60	6V1021	BRUSH CAP	1
16	4E4041	BEARING	1	38	4G2032	PINION GEAR (17T)	4				
17	4W4213	WASHER	1	39	4L1051	TOP GEAR HOLDER	1				
18	4B1024	BALL BEARING	16	40	4G2032	PINION GEAR (17T)	4				
19	4K3041	BOTTOM CLUTCH	1	41	4W3011	WASHER	1				
20	4W5213	WASHER	1	42	4G1034	MAIN GEAR (14T)	1				
21	4B201 5	BALL BEARING	2	43	8S6504	MACHINE SCREW	4				
22	4B2018	BALL BEARING	2	44	2A1011	MOTOR WITH FAN	1				
23	4C1072	TOOL BIT HOLDER	1	46	2C4011	CONDENSER (0.1K 100V)	1				
23-1	4C2021	ANVIL INNER SHAFT (NOT SHOWN)	1	47	6Z1061	PLASTIC HOUSING (RIGHT)	1				

### FOOTNOTES



**AIMCO**

When ordering spare parts, please specify tool type, part number and description.

10000 SE PINE, PORTLAND, OR 97216  
503-254-6600 FAX 503-255-2615